

CATÁLOGO TÉCNICO

 TECHNICAL CATALOGUE

Escrito por Fermator.
Writing by Fermator.

Diseño multimedia y producción por Fermator.
Multimedia design and production by Fermator.

Segunda Edición 2008.
2008 Second Edition.

Tec nolama, S.A.
Ctra. Constantí, km3
43206 Reus (Tarragona)
España-Spain

Fermator se reserva el derecho de modificar las especificaciones de los productos de este catálogo sin previo aviso.

Fermator reserves the right to make changes to the specification of the products within this catalogue without prior notice.

ÍNDICE GENERAL

1. Puerta central de 2 hojas :

- 1.1. Puerta cabina central de 2 hojas, modelo VVVF.
- 1.2. Puerta rellano central de 2 hojas, sin frontis, modelo 40/10.
- 1.3. Puerta rellano central de 2 hojas, con frontis, modelo 40/10.
- 1.4. Puerta rellano central de 2 hojas, modelo 40/10 DIN 18.091.
- 1.5. Puerta rellano central de 2 hojas, sin frontis, modelo 50/11.
- 1.6. Puerta rellano central de 2 hojas, modelo 50/11 DIN 18.091.
- 1.7. Situación del patín con las ruedas de arrastre (puerta de rellano 40/10).
- 1.8. Situación del patín con las ruedas de arrastre (puerta de rellano 50/11).

2. Puerta central de 4 hojas :

- 2.1. Puerta cabina central de 4 hojas, modelo VVVF, con un motor (PL600 hasta PL1000).
- 2.2. Puerta cabina central de 4 hojas, modelo VVVF, con dos motores (PL 1100 hasta PL 3000).
- 2.3. Puerta rellano central de 4 hojas, sin frontis, modelo 40/10 con un enclavamiento.
- 2.4. Puerta rellano central de 4 hojas, sin frontis, modelo 40/10 con doble enclavamiento.
- 2.5. Puerta rellano central de 4 hojas, con frontis, modelo 40/10 con un enclavamiento.
- 2.6. Puerta rellano central de 4 hojas, con frontis, modelo 40/10 con doble enclavamiento.
- 2.7. Puerta rellano central de 4 hojas, modelo 40/10 DIN 18.091 con un enclavamiento.
- 2.8. Puerta rellano central de 4 hojas, modelo 40/10 DIN 18.091 con doble enclavamiento.
- 2.9. Puerta rellano central de 4 hojas, sin frontis, modelo 50/11 con un enclavamiento (PL 600 hasta 1100 mm.).
- 2.10. Puerta rellano central de 4 hojas, sin frontis, modelo 50/11 con doble enclavamiento (PL \geq 1200 mm.).
- 2.11. Puerta rellano central de 4 hojas, modelo 50/11 DIN 18.091 con un enclavamiento (PL 600 hasta 1100 mm.).
- 2.12. Puerta rellano central de 4 hojas, modelo 50/11 DIN 18.091 con doble enclavamiento (PL \geq 1200 mm.).
- 2.13. Situación del patín con ruedas de arrastre (puerta de rellano 40/10).
- 2.14. Situación del patín con ruedas de arrastre (puerta de rellano 50/11).

ÍNDICE GENERAL

3. Puerta central de 6 hojas :

- 3.1. Puerta cabina central de 6 hojas, modelo VVVF.
- 3.2. Puerta rellano central de 6 hojas, sin frontis, modelo 40/10.
- 3.3. Puerta rellano central de 6 hojas, con frontis, modelo 40/10.
- 3.4. Puerta rellano central de 6 hojas, modelo 40/10 DIN 18.091.
- 3.5. Puerta rellano central de 6 hojas, sin frontis, modelo 50/11.
- 3.6. Puerta rellano central de 6 hojas, modelo 50/11 DIN 18.091.
- 3.7. Situación del patín con las ruedas de arrastre (puerta de rellano 40/10).
- 3.8. Situación del patín con las ruedas de arrastre (puerta de rellano 50/11).
- 3.9. Situación del patín con las ruedas de arrastre (puerta de rellano 40/10 y pisadera 90 mm).

4. Puerta central de 8 hojas :

- 4.1. Puerta cabina central de 8 hojas, modelo VVVF.
- 4.2. Puerta rellano central de 8 hojas, sin frontis, modelo 40/10.
- 4.3. Puerta rellano central de 8 hojas, con frontis, modelo 40/10.
- 4.4. Puerta central de 8 hojas, sin frontis, modelo 50/11.
- 4.5. Situación del patín con las ruedas de arrastre (puerta de rellano 40/10).
- 4.6. Situación del patín con las ruedas de arrastre (puerta de rellano 50/11).

5. Puerta lateral de 1 hoja :

- 5.1. Puerta cabina lateral de 1 hoja, modelo VVVF.
- 5.2. Puerta rellano lateral de 1 hoja, sin frontis, modelo 40/10.
- 5.3. Puerta rellano lateral de 1 hoja, con frontis, modelo 40/10.
- 5.4. Puerta rellano lateral de 1 hoja, sin frontis, modelo 50/11.
- 5.5. Puerta rellano lateral de 1 hoja, modelo 50/11 DIN 18.091.
- 5.6. Situación del patín con las ruedas de arrastre (puerta de rellano 40/10).
- 5.7. Situación del patín con las ruedas de arrastre (puerta de rellano 50/11).

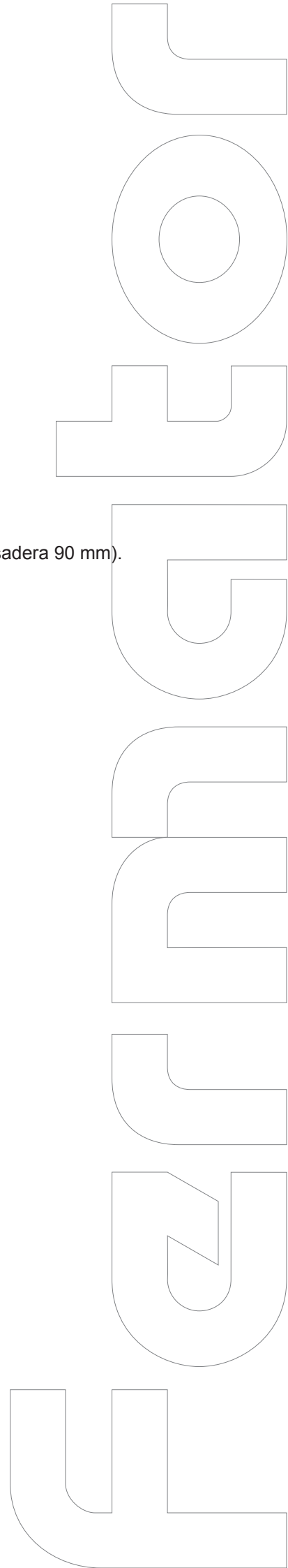

ÍNDICE GENERAL

6. Puerta telescópica de 2 hojas :

- 6.1. Puerta cabina telescópica de 2 hojas, modelo VVVF.
- 6.2. Puerta rellano telescópica de 2 hojas, sin frontis, modelo 40/10.
- 6.3. Puerta rellano telescópica de 2 hojas, con frontis, modelo 40/10.
- 6.4. Puerta rellano telescópica de 2 hojas, modelo 40/10 DIN 18.091.
- 6.5. Puerta rellano telescópica de 2 hojas, sin frontis, modelo 50/11.
- 6.6. Puerta rellano telescópica de 2 hojas, modelo 50/11 DIN 18.091.
- 6.7. Situación del patín con las ruedas de arrastre (puerta de rellano 40/10).
- 6.8. Situación del patín con las ruedas de arrastre (puerta de rellano 50/11).
- 6.9. Situación del patín con las ruedas de arrastre (puerta de rellano 40/10 y pisadera de 70 mm).

7. Puerta telescópica de 3 hojas :

- 7.1. Puerta cabina telescópica de 3 hojas, modelo VVVF.
- 7.2. Puerta rellano telescópica de 3 hojas, sin frontis, modelo 40/10.
- 7.3. Puerta rellano telescópica de 3 hojas, con frontis, modelo 40/10.
- 7.4. Puerta rellano telescópica de 3 hojas, modelo 40/10 DIN 18.091.
- 7.5. Puerta rellano telescópica de 3 hojas, sin frontis, modelo 50/11.
- 7.6. Puerta rellano telescópica de 3 hojas, modelo 50/11 DIN 18.091.
- 7.7. Situación del patín con las ruedas de arrastre (puerta de rellano 40/10).
- 7.8. Situación del patín con las ruedas de arrastre (puerta de rellano 50/11).
- 7.9. Situación del patín con las ruedas de arrastre (puerta de rellano 40/10 y pisadera de 90 mm).

8. Puerta telescópica de 4 hojas :

- 8.1. Puerta cabina telescópica de 4 hojas, modelo VVVF.
- 8.2. Puerta rellano telescópica de 4 hojas, sin frontis, modelo 40/10.
- 8.3. Puerta rellano telescópica de 4 hojas, con frontis, modelo 40/10.
- 8.4. Puerta rellano telescópica de 4 hojas, sin frontis, modelo 50/11.
- 8.5. Situación del patín con las ruedas de arrastre (puerta de rellano 40/10).
- 8.6. Situación del patín con las ruedas de arrastre (puerta de rellano 50/11).

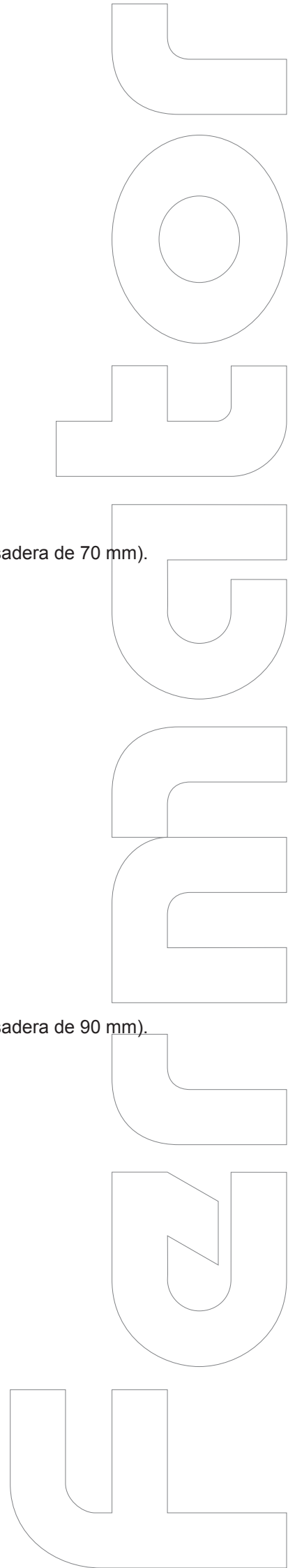

ÍNDICE GENERAL

9. Puertas de cristal :

- 9.1. Puerta de cabina de cristal total (para todo tipo de puertas centrales).
- 9.2. Puerta de cabina de cristal total (para todo tipo de puertas telescópicas).
- 9.3. Puerta de rellano central de cristal total.
- 9.4. Puerta de rellano telescópica de cristal total.
- 9.5. Detalle hoja de cristal total.
- 9.6. Situación del patín con las ruedas de arrastre (puerta central de 2 hojas 50/11).
- 9.7. Situación del patín con las ruedas de arrastre (puerta central de 4 hojas 50/11).
- 9.8. Hoja de cristal total (para todo tipo de puertas).
- 9.9. Puertas de cristal con perfil de aluminio (para todo tipo de puertas centrales).
- 9.10. Puertas de cristal con perfil de aluminio (para todo tipo de puertas telescópicas).
- 9.11. Puerta central de rellano de cristal con perfil de aluminio.
- 9.12. Puerta telescópica de rellano de cristal con perfil de aluminio.
- 9.13. Hoja de cristal con perfil de aluminio.
- 9.14. Detalle hoja de cristal con perfil de aluminio.
- 9.15. Puerta modelo «Gran Mirilla» (para todo tipo de puertas centrales).
- 9.16. Puerta modelo «Gran Mirilla» (para todo tipo de puertas telescópicas).
- 9.17. Detalle hojas modelo «Gran Mirilla» (para todo tipo de puertas).
- 9.18. Detalle hojas modelo «Gran Mirilla».
- 9.19. Detalle hoja modelo «Gran Mirilla modelo enrasado».

10. Puerta de rellano semiautomática :

- 10.1. Puerta de rellano semiautomática con mirilla, modelo «Fermator».
- 10.2. Puerta de rellano semiautomática sin mirilla, modelo «Fermator».
- 10.3. Puerta de rellano semiautomática con mirilla, modelo «Global».
- 10.4. Puerta de rellano semiautomática sin mirilla, modelo «Global».
- 10.5. Puerta de rellano semiautomática modelo «Gran Mirilla».

11. Puertas plegables :

- 11.1. Puerta de cabina plegable de 4 hojas (modelo Estándar).
- 11.2. Puerta de cabina plegable de 4 hojas, modelos «G» y «O».
- 11.3. Puerta de cabina plegable de 4 hojas (modelo Plano).
- 11.4. Puerta de cabina plegable de 4 hojas modelo ECC.
- 11.5. Puerta de cabina plegable modelo LB.
- 11.6. Puerta de rellano plegable modelo LB.
- 11.7. Leva retráctil lateral para puerta plegable.
- 11.8. Leva retráctil frontal para puerta plegable.
- 11.9. Leva retráctil lateral para puerta plegable modelo ECC.
- 11.10. Leva retráctil frontal para puerta plegable modelo ECC.

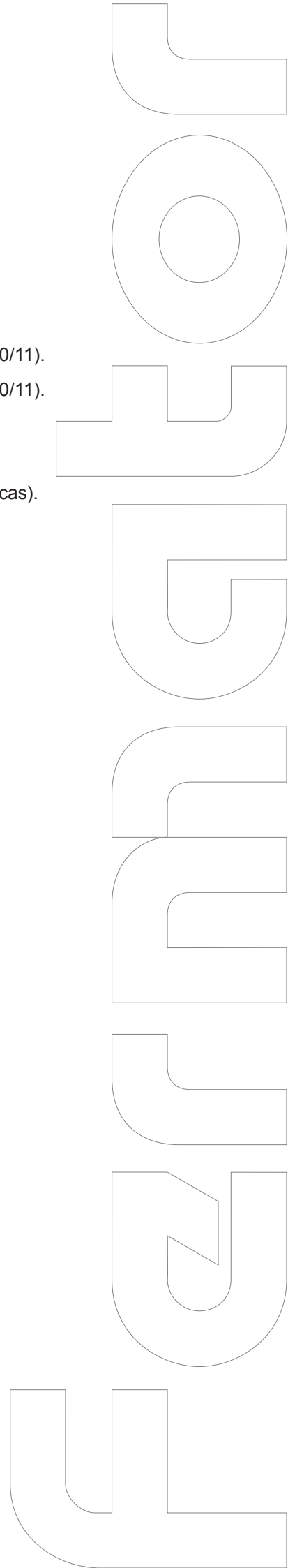

ÍNDICE GENERAL

12. Puertas especiales y complementos para reformas :

- 12.1. Puerta de rellano central de 2 hojas (puerta de rellano sin cerco, especial para reformas).
- 12.2. Puerta de cabina central de 4 hojas, modelo VVVF (puerta rellano automática y pisadera de 70mm).
- 12.3. Puerta de cabina central de 4 hojas, modelo VVVF 40/10 (PL700, puerta de rellano semiautomática y pisadera de 70mm).
- 12.4. Puerta de cabina central de 4 hojas, modelo VVVF 40/10 (PL700, puerta de rellano semiautomática y pisadera de 80mm).
- 12.5. Puerta de rellano central de 4 hojas, modelo 40/10 (puerta de rellano sin cerco, especial para reformas).
- 12.6. Puerta de rellano central de 4 hojas, modelo 50/11 (puerta de rellano sin cerco especial para reformas).
- 12.7. Detalle de montaje puertas de rellano centrales (puerta de rellano sin cerco para reformas).
- 12.8. Útil de montaje para puertas de rellano sin cerco.
- 12.9. Puerta de cabina telescópica de 2 hojas, modelo VVVF (puerta de rellano automática y pisadera de 70mm).
- 12.10. Puerta de cabina telescópica de 2 hojas, modelo VVVF (puerta de rellano semiautomática y pisadera de 70mm).
- 12.11. Puerta de rellano telescópica de 2 hojas, modelo 40/10 (puerta de rellano sin cerco, especial para reformas).
- 12.12. Puerta de rellano telescópica de 2 hojas, modelo 50/11 (puerta de rellano sin cerco, especial para reformas).
- 12.13. Detalle de montaje para puertas de rellano telescópicas (puerta de rellano sin cerco, especial para reformas).
- 12.14. Útil de montaje para puertas de rellano sin cerco.
- 12.15. Puerta de cabina telescópica de 3 hojas, modelo VVVF 40/10 (con puerta de rellano automática y pisadera de 90mm).
- 12.16. Puerta de cabina telescópica de 3 hojas, modelo VVVF 40/10 (con puerta de rellano semiautomática y pisadera de 90mm).
- 12.17. Puerta de cabina telescópica de 3 hojas, modelo VVVF 40/10 (con puerta de rellano semiautomática y pisadera de 70mm).
- 12.18. Patín móvil para puertas de rellano automáticas.
- 12.19. Leva retráctil lateral para puerta semiautomática (para todo tipo de puertas de cabina telescópicas).
- 12.20. Leva retráctil invertida para puerta semiautomática (para todo tipo de puertas de cabina telescópicas).
- 12.21. Leva retráctil frontal para puerta frontal (para todo tipo de puertas de cabina telescópicas).
- 12.22. Kit modernización VVVF.
- 12.23. Kit modernización VVVF con sistema de retención.

ÍNDICE GENERAL

13. Soluciones específicas:

- 13.1. Niveles de refuerzo.
- 13.2. Puerta circular.
- 13.3. Puerta circular.
- 13.4. Puerta de cabina central de 2 hojas con operador inferior.
- 13.5. Puerta de rellano central de 3 hojas con mecanismo inferior
- 13.6. Kit barrera fotoeléctrica (para todo tipo de puertas centrales).
- 13.7. Kit barrera fotoeléctrica (para todo tipo de puertas telescópicas).
- 13.8. Mecanismo motorizado.
- 13.9. Operador Frontal.
- 13.10. Puerta de cabina telescópica 2 hojas modelo RAC 250.
- 13.11. Marco de rellano modelo MSS.
- 13.12. Módulo electrónico VVVF 4+.
- 13.13. Regulación del enclavamiento 40/10 (para todo tipo de puertas de rellano automáticas).
- 13.14. Regulación del enclavamiento 50/11 (para todo tipo de puertas de rellano automáticas).
- 13.15. Patín Especial.
- 13.16. Enclavamiento de cabina (CDL-S) para puertas centrales.
- 13.17. Enclavamiento de cabina (CDL-S) para puertas telescópicas.
- 13.18. Patín para puertas de ascensor inclinadas.
- 13.19. Escuadras de fijación a la pared (para todo tipo de puertas de rellano automáticas).
- 13.20. Escuadras de fijación a la pared (para todo tipo de puertas de rellano automáticas).
- 13.21. Escuadras de fijación a la pared (para todo tipo de puertas de rellano automáticas).
- 13.22. Uso de las diferentes escuadras.
- 13.23. Modelos de pisadera disponibles (para todo tipo de puertas).
- 13.24. Producto especial.

14. Homologaciones de fuego:

- 14.1. Puerta de rellano central 2 hojas E-120.
- 14.2. Puerta de rellano telescópica 2 hojas E-120.
- 14.3. Puerta de rellano central 2 hojas EW-60/30.
- 14.4. Puerta de rellano telescópica 2 hojas EW-60/30.
- 14.5. Puerta de rellano central 2 hojas EI-120/60.
- 14.6. Puerta de rellano telescópica 2 hojas EI-120/60.
- 14.7. Homologaciones.

15. Formularios de pedidos.

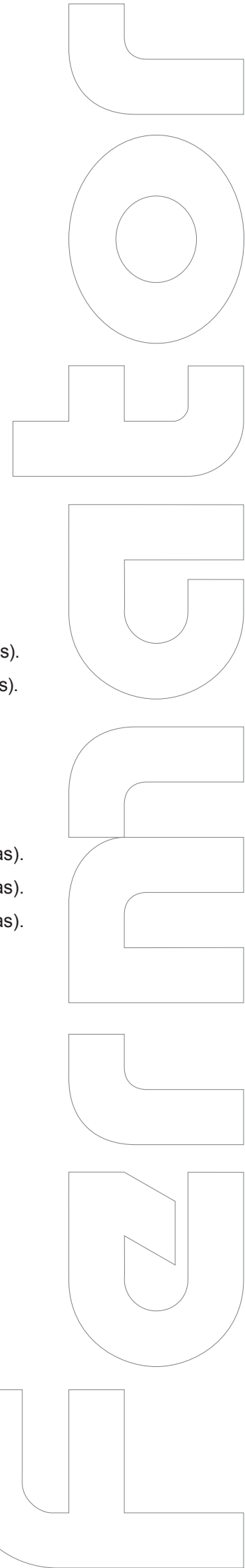

MAIN INDEX

1. 2 Panel centre parting doors :

- 1.1. 2 Panel centre parting car door, model VVVF.
- 1.2. 2 Panel centre parting landing door, without infill panels, model 40/10.
- 1.3. 2 Panel centre parting landing door, with infill panels, model 40/10.
- 1.4. 2 Panel centre parting landing door, model 40/10 DIN 18.091.
- 1.5. 2 Panel centre parting landing door, without infill panels, model 50/11.
- 1.6. 2 Panel centre parting landing door, model 50/11 DIN 18.091.
- 1.7. Coupling arrangement between skate and lock (landing door 40/10).
- 1.8. Coupling arrangement between skate and lock (landing door 50/11).

2. 4 Panel centre parting doors :

- 2.1. 4 Panel centre parting car door, model VVVF, with one motor, (CO 600 to CO 1000).
- 2.2. 4 Panel centre parting car door, model VVVF, with two motors, (CO 1100 to CO 3000).
- 2.3. 4 Panel centre parting landing door, without infill panels, model 40/10 with one locking device.
- 2.4. 4 Panel centre parting landing door, without infill panels, model 40/10 with two locking device.
- 2.5. 4 Panel centre parting landing door, with infill panels, model 40/10 with one locking device.
- 2.6. 4 Panel centre parting landing door, with infill panels, model 40/10 with two locking device.
- 2.7. 4 Panel centre parting landing door, model 40/10 DIN 18.091 with one locking device.
- 2.8. 4 Panel centre parting landing door, model 40/10 DIN 18.091 with two locking device.
- 2.9. 4 Panel centre parting landing door, without infill panels, model 50/11 with one locking device (CO 600 to 1100 mm.).
- 2.10. 4 Panel centre parting landing door, without infill panels, model 50/11 with two locking device (CO \geq 1200 mm.).
- 2.11. 4 Panel centre parting landing door, model 50/11 DIN 18.091 with one locking device (CO 600 to 1100 mm.).
- 2.12. 4 Panel centre parting landing door, model 50/11 DIN 18.091 with two locking device (CO \geq 1200 mm.).
- 2.13. Coupling arrangement between skate and lock (landing door 40/10).
- 2.14. Coupling arrangement between skate and lock (landing door 50/11).

MAIN INDEX

3. 6 Panel centre parting door :

- 3.1. 6 Panel centre parting car door, model VVVF.
- 3.2. 6 Panel centre parting landing door, without infill panels, model 40/10.
- 3.3. 6 Panel centre parting landing door, with infill panels, model 40/10.
- 3.4. 6 Panel centre parting landing door, model 40/10 DIN 18.091.
- 3.5. 6 Panel centre parting landing door, without infill panels, model 50/11.
- 3.6. 6 Panel centre parting landing door, model 50/11 DIN 18.091.
- 3.7. Coupling arrangement between skate and lock (landing door 40/10).
- 3.8. Coupling arrangement between skate and lock (landing door 50/11).
- 3.9. Coupling arrangement between skate and lock (landing door 40/10 and sill 90 mm).

4. 8 Panel centre parting door :

- 4.1. 8 Panel centre parting car door, model VVVF.
- 4.2. 8 Panel centre parting landing door, without infill panels, model 40/10.
- 4.3. 8 Panel centre parting landing, with infill panels, model 40/10.
- 4.4. 8 Panel centre parting landing door, without infill panels, model 50/11.
- 4.5. Coupling arrangement between skate and lock (landing door 40/10).
- 4.6. Coupling arrangement between skate and lock (landing door 50/11).

5. 1 Panel side opening door :

- 5.1. 1 Panel side opening car door, model VVVF.
- 5.2. 1 Panel side opening landing door, without infill panels, model 40/10.
- 5.3. 1 Panel side opening landing door, with infill panels, model 40/10.
- 5.4. 1 Panel side opening landing door, without infill panels, model 50/11.
- 5.5. 1 Panel side opening landing door, model 50/11 DIN 18.091.
- 5.6. Coupling arrangement between skate and lock (landing door 40/10).
- 5.7. Coupling arrangement between skate and lock (landing door 50/11).

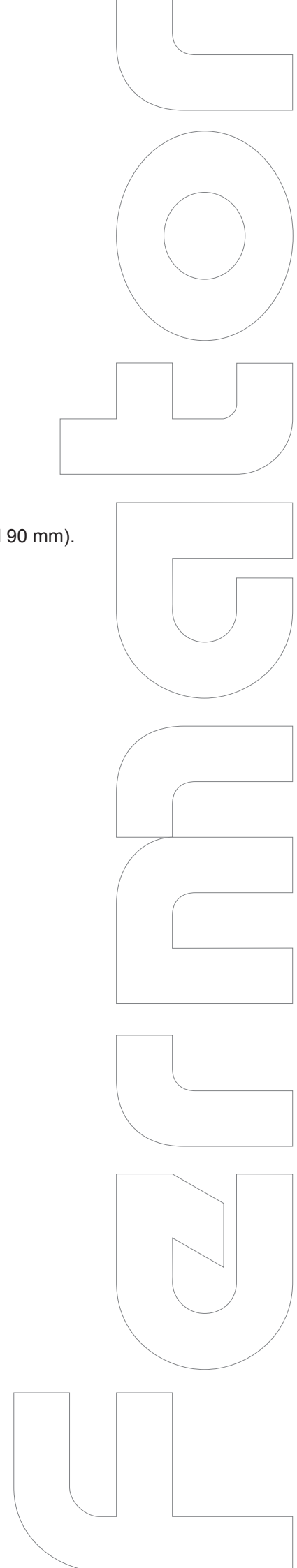

MAIN INDEX

6. 2 Panel side opening door :

- 6.1. 2 Panel side opening car door, model VVVF.
- 6.2. 2 Panel side opening landing door, without infill panels, model 40/10.
- 6.3. 2 Panel side opening landing door, with infill panels, model 40/10.
- 6.4. 2 Panel side opening landing door, model 40/10 DIN 18.091.
- 6.5. 2 Panel side opening landing door, without infill panels, model 50/11.
- 6.6. 2 Panel side opening landing door, model 50/11 DIN 18.091.
- 6.7. Coupling arrangement between skate and lock (landing door 40/10).
- 6.8. Coupling arrangement between skate and lock (landing door 50/11).
- 6.9. Coupling arrangement between skate and lock (landing door 40/10 and sill 70 mm).

7. 3 Panel side opening door :

- 7.1. 3 Panel side opening car door, model VVVF.
- 7.2. 3 Panel side opening landing door, without infill panels, model 40/10.
- 7.3. 3 Panel side opening landing door, with infill panels, model 40/10.
- 7.4. 3 Panel side opening landing door, model 40/10 DIN 18.091.
- 7.5. 3 Panel side opening landing door, without infill panels, model 50/11.
- 7.6. 3 Panel side opening landing door, model 50/11 DIN 18.091.
- 7.7. Coupling arrangement between skate and lock (landing door 40/10).
- 7.8. Coupling arrangement between skate and lock (landing door 50/11).
- 7.9. Coupling arrangement between skate and lock (landing door 40/10 and sill 90 mm).

8. 4 Panel side opening door :

- 8.1. 4 Panel side opening car door, model VVVF.
- 8.2. 4 Panel side opening landing door, without infill panels, model 40/10.
- 8.3. 4 Panel side opening landing door, with infill panels, model 40/10.
- 8.4. 4 Panel side opening landing door, without infill panels, model 50/11.
- 8.5. Coupling arrangement between skate and lock (landing door 40/10).
- 8.6. Coupling arrangement between skate and lock (landing door 50/11).

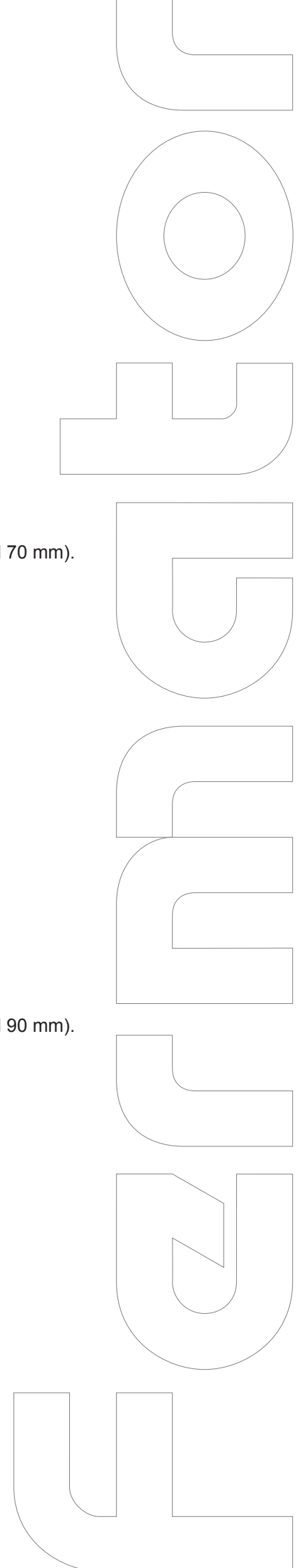

MAIN INDEX

9. Glass Door :

- 9.1. Full glass cabin door (for all type of centre parting doors).
- 9.2. Full glass cabin door (for all type of side opening doors).
- 9.3. Full glass centre parting landing door.
- 9.4. Full glass telescopic landing door.
- 9.5. Detail of full glass panel.
- 9.6. Coupling arrangement between skate and lock (2 panel centre parting door 50/11).
- 9.7. Coupling arrangement between skate and lock (4 panel centre parting door 50/11).
- 9.8. Full glass panel (for all type of doors).
- 9.9. Glass door with aluminium profile (for all type of centre parting doors).
- 9.10. Glass door with aluminium profile (for all type of side opening doors).
- 9.11. Central parting landing glass door with aluminium profile.
- 9.12. Telescopic landing glass door with aluminium profile.
- 9.13. Glass panel with aluminium profile.
- 9.14. Glass panel with aluminium profil detail.
- 9.15. «Big Vision» panel model doors (for all type of centre parting doors).
- 9.16. «Big Vision» panel model doors (for all type of side opening doors).
- 9.17. «Big Vision» panel detail (for all type of doors).
- 9.18. Detail of «Big Vision» panel.
- 9.19. «Big Vision panel flush type» detail.

10. Hinged semi-automatic landing door :

- 10.1. Hinged semi-automatic landing door with vision panel, «Fermator» type.
- 10.2. Hinged semi-automatic landing door without vision panel, «Fermator» type.
- 10.3. Hinged semi-automatic landing door with vision panel, «Global» type.
- 10.4. Hinged semi-automatic landing door without vision panel, «Global» type.
- 10.5. Hinged semi-automatic landing door, «Big Vision» model.

11. Automatic folding doors :

- 11.1. 4 Panel folding far door (Standard model).
- 11.2. 4 Panel folding car door (models «G» and «O»).
- 11.3. 4 Panel folding car door (Flat model).
- 11.4. 4 Panel folding car door ECC model.
- 11.5. Folding car door LB model.
- 11.6. Folding landing door LB model.
- 11.7. Side acting retractable cam for folding door.
- 11.8. Front acting retractable cam for folding door.
- 11.9. Side acting retractable cam for folding door ECC model.
- 11.10. Front acting retractable cam for folding door ECC model.

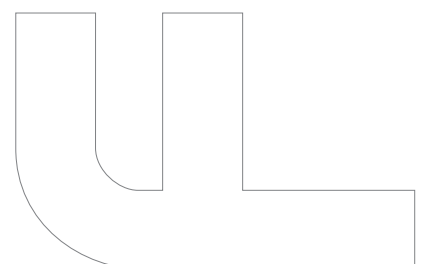
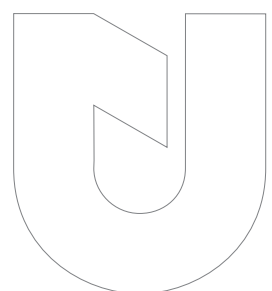
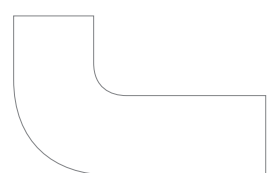
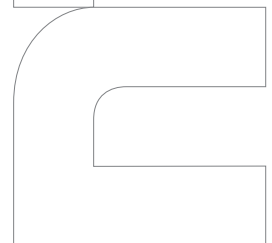
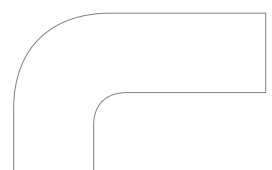
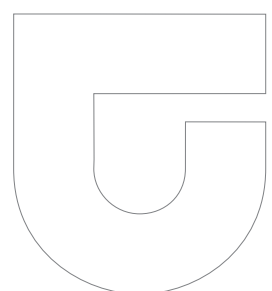
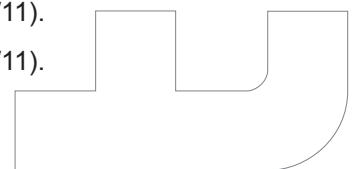
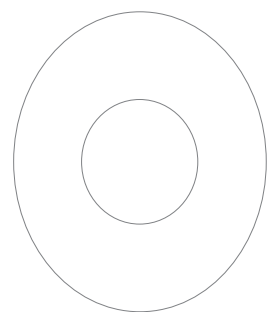

MAIN INDEX

12. Doors and special complements for modernization :

- 12.1. 2 Panels centre parting landing door (landing door without frames, for modernization).
- 12.2. 4 Panels centre parting car door, VVVF model (with automatic landing door and flush sill of 70mm).
- 12.3. 4 Panels centre parting car door, VVVF 40/10 model (CO 700, with hinged semi-automatic landing door and flush sill of 70mm).
- 12.4. 4 Panels centre parting car door, VVVF 40/10 model (CO 700, with hinged semi-automatic landing door and flush sill of 80mm).
- 12.5. 4 Panels centre parting landing door, 40/10 model (landing door without frames for modernization).
- 12.6. 4 Panels centre parting landing door, 50/11 model (landing door without frames for modernization).
- 12.7. Assembly detail of centre parting landing doors (landing door without frames for modernization).
- 12.8. Assembling tool of landing door without frames.
- 12.9. 2 Panel side opening car door, VVVF model (with automatic landing door and flush sill of 70mm).
- 12.10. 2 Panel side opening car door, VVVF model (with hinged semi-automatic landing door and flush sill of 70mm).
- 12.11. 2 Panels side opening landing door, 40/10 model (landing door without frames for modernization).
- 12.12. 2 Panels side opening landing door, 50/11 model (landing door without frames for modernization).
- 12.13. Assembly detail of side opening landing doors (landing door without frames for modernization).
- 12.14. Assembling tool of landing door without frames.
- 12.15. 3 Panels side opening car door VVVF 40/10 model (with automatic landing door and flush sill of 90mm).
- 12.16. 3 Panels side opening car door VVVF 40/10 model (with hinged semi-automatic landing door and flush sill of 90mm).
- 12.17. 3 Panels side opening car door VVVF 40/10 model (with hinged semi-automatic landing door and flush sill of 70mm).
- 12.18. Skate for automatic landing doors.
- 12.19. Side acting retractable cam (for all type of side opening car doors).
- 12.20. Inverted retractable cam (for all type of side opening car doors).
- 12.21. Frontal acting retractable cam (for all type of side opening car doors).
- 12.22. VVVF modernization kit.
- 12.23. VVVF modernization kit with retention system.

MAIN INDEX

13. Documentation and various special products:

- 13.1. Reinforcement level.
- 13.2. Round door.
- 13.3. Round door.
- 13.4. 2 Panel centre parting car door with under driven operator.
- 13.5. 2 Panel centre parting car door with under driven mechanism.
- 13.6. Kit of photocell barrier (for centre door).
- 13.7. Kit of photocell barrier (for side opening door).
- 13.8. Motorized mechanism.
- 13.9. Frontal operator.
- 13.10. RAC 250 model 2 panels side opening car door.
- 13.11. Landing frame MSS model.
- 13.12. VVVF 4+ electrónical module.
- 13.13. 40/10 landing door lock adjustments (for all type of automatic landing doors).
- 13.14. 50/11 landing door lock adjustments (for all type of automatic landing doors).
- 13.15. Special skate.
- 13.16. Car locking device (CDL-S) for central parting doors.
- 13.17. Car locking device (CDL-S) for side opening doors.
- 13.18. Angular door lift skate.
- 13.19. Door frame mounting brackets (for all type of automatic landing doors).
- 13.20. Door frame mounting brackets (for all type of automatic landing doors).
- 13.21. Door frame mounting brackets (for all type of automatic landing doors).
- 13.22. Use of different brackets.
- 13.23. Types of sill available.
- 13.24. Special product.

14. Fire homologations:

- 14.1. 2 panels central parting landing door E-120.
- 14.2. 2 panels side opening landing door E-120.
- 14.3. 2 panels central parting landing door EW-60/30.
- 14.4. 2 panels side opening landing door EW-60/30.
- 14.5. 2 panels central parting landing door EI-120/60.
- 14.6. 2 panels side opening landing door EI-120/60.
- 14.7. Homologations.

15. Enquiry / Order from.

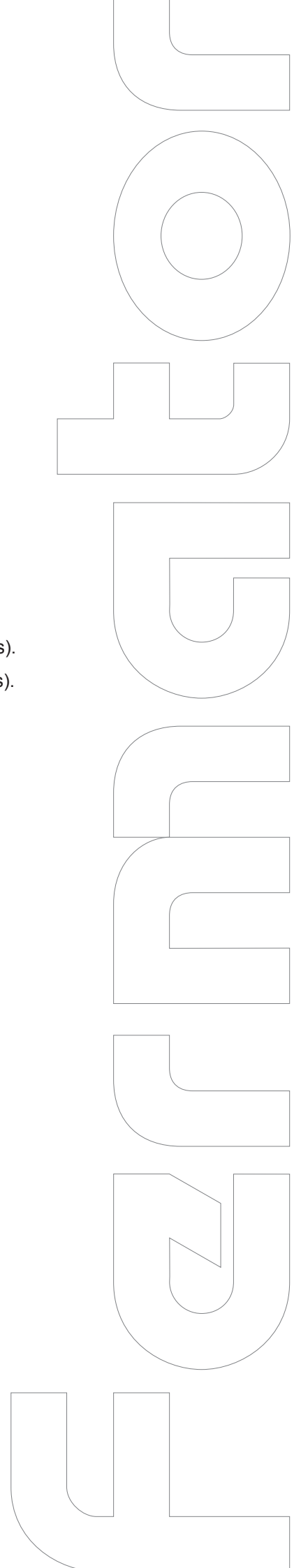

Ferrotec

AUTOMATIC DOORS FOR LIFTS

PUERTA CENTRAL DE 2 HOJAS
2 PANEL CENTRE PARTING DOOR

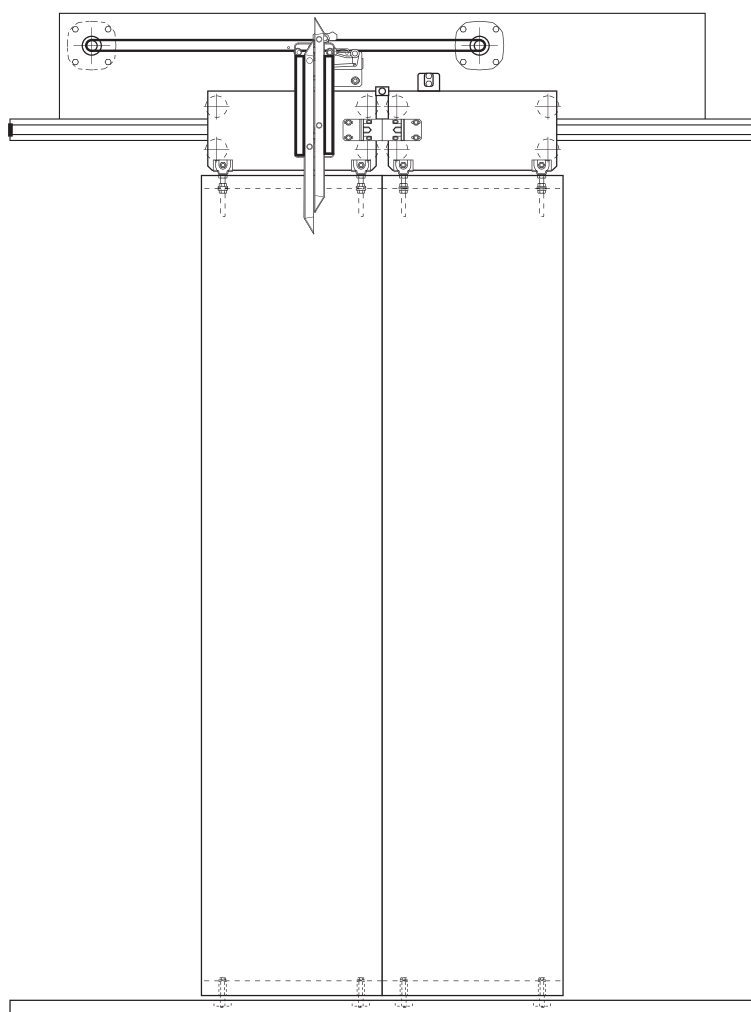

1

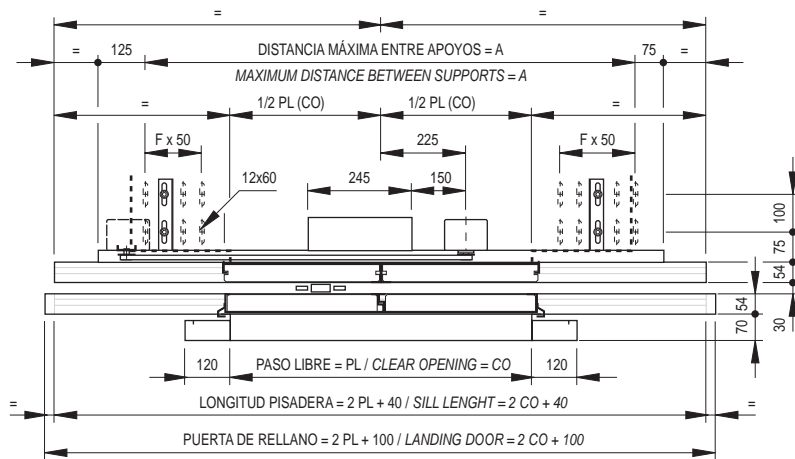
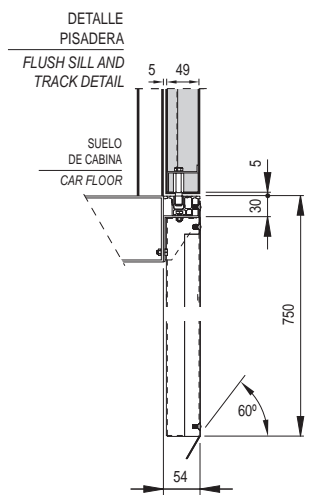
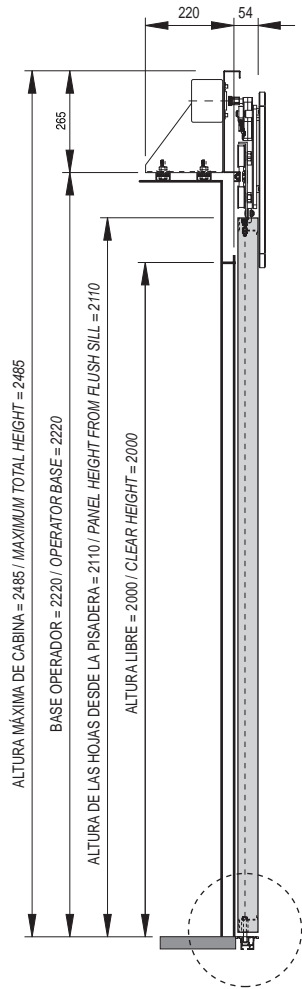
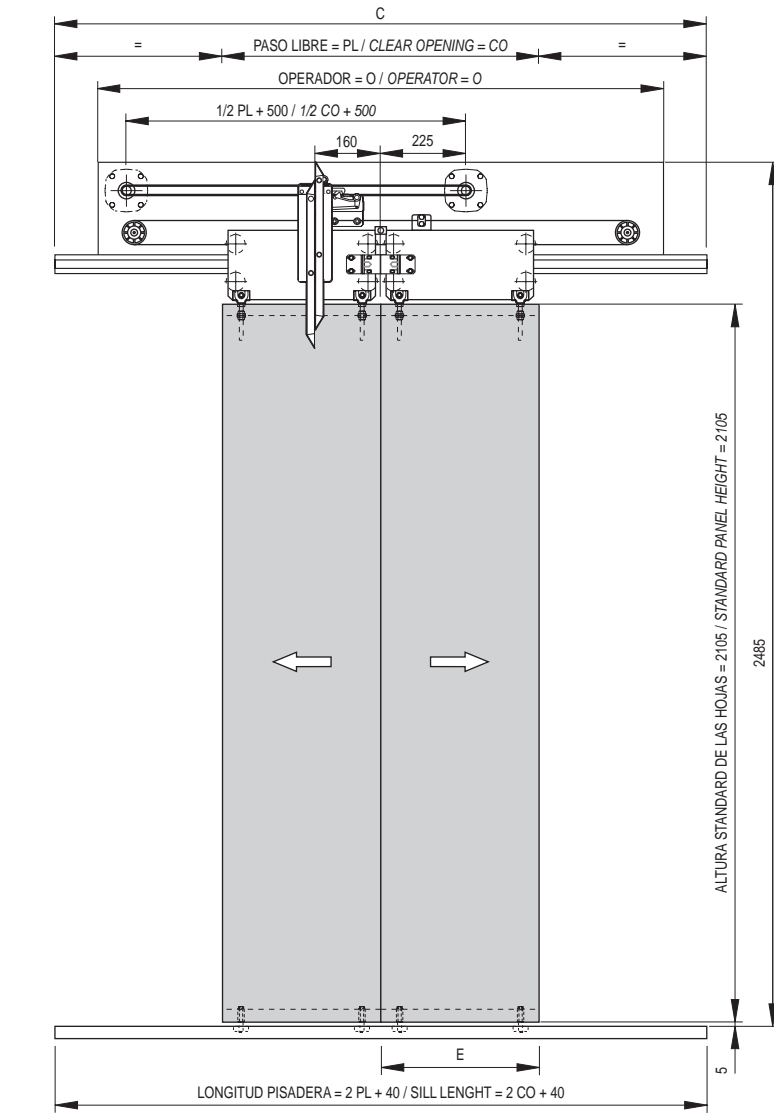

| PL / CO | Un Motor / One Motor | | | | | | | | Dos Motores / Two Motors | | | | | | | | | |
|--------------------|----------------------|------|------|------|------|------|------|------|--------------------------|------|------|-------|-------|------|------|-------|-------|------|
| | 600 | 650 | 700 | 750 | 800 | 850 | 900 | 1000 | 1100 | 1200 | 1300 | 1400 | 1500 | 1600 | 1700 | 1800 | 1900 | 2000 |
| A | 1000 | 1050 | 1200 | 1250 | 1300 | 1350 | 1400 | 1500 | 1600 | 2000 | 2100 | 2200 | 2300 | 2400 | 2500 | 2600 | 2700 | 2800 |
| C | 1250 | 1350 | 1450 | 1550 | 1650 | 1750 | 1850 | 2050 | 2250 | 2450 | 2650 | 2850 | 3050 | 3250 | 3450 | 3650 | 3850 | 4050 |
| O | 1200 | 1250 | 1400 | 1450 | 1500 | 1550 | 1600 | 1700 | 1800 | 2200 | 2300 | 2400 | 2500 | 2600 | 2700 | 2800 | 2900 | 3000 |
| E | 320 | 345 | 370 | 395 | 420 | 445 | 470 | 520 | 570 | 620 | 670 | 720 | 770 | 820 | 870 | 920 | 970 | 1020 |
| F | 4 | 4 | 5 | 6 | 6 | 7 | 7 | 8 | 9 | 13 | 14 | 15 | 16 | 17 | 18 | 19 | 20 | 21 |
| TIEMPO / TIME (s) | 1,22 | 1,27 | 1,32 | 1,37 | 1,41 | 1,45 | 1,55 | 1,58 | 1,66 | 1,73 | 1,8 | 1,87 | 1,94 | 2 | 2,06 | 2,12 | 2,18 | 2,24 |
| PESO / WEIGHT (kg) | 52,5 | 57 | 61,5 | 66 | 70 | 74,5 | 79 | 87,5 | 96,5 | 105 | 114 | 122,5 | 131,5 | 140 | 149 | 157,5 | 166,5 | 175 |

1

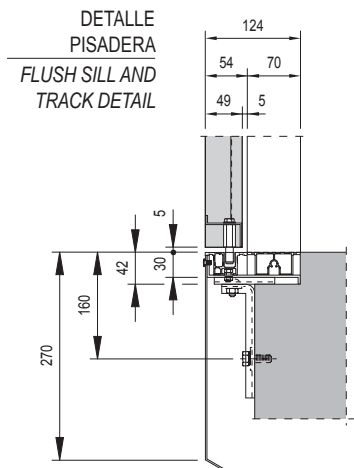
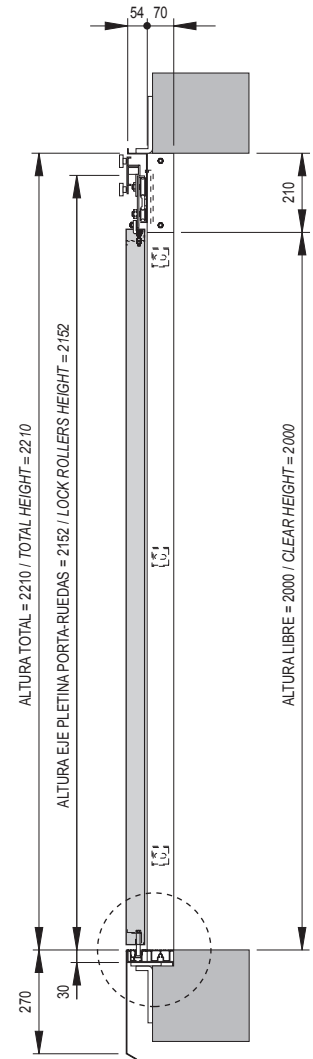
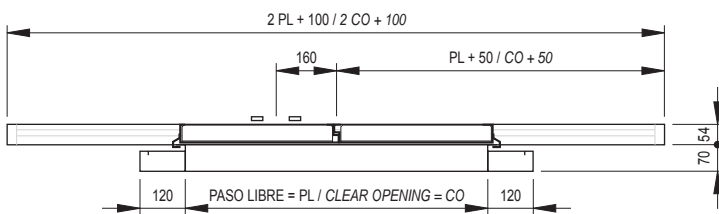
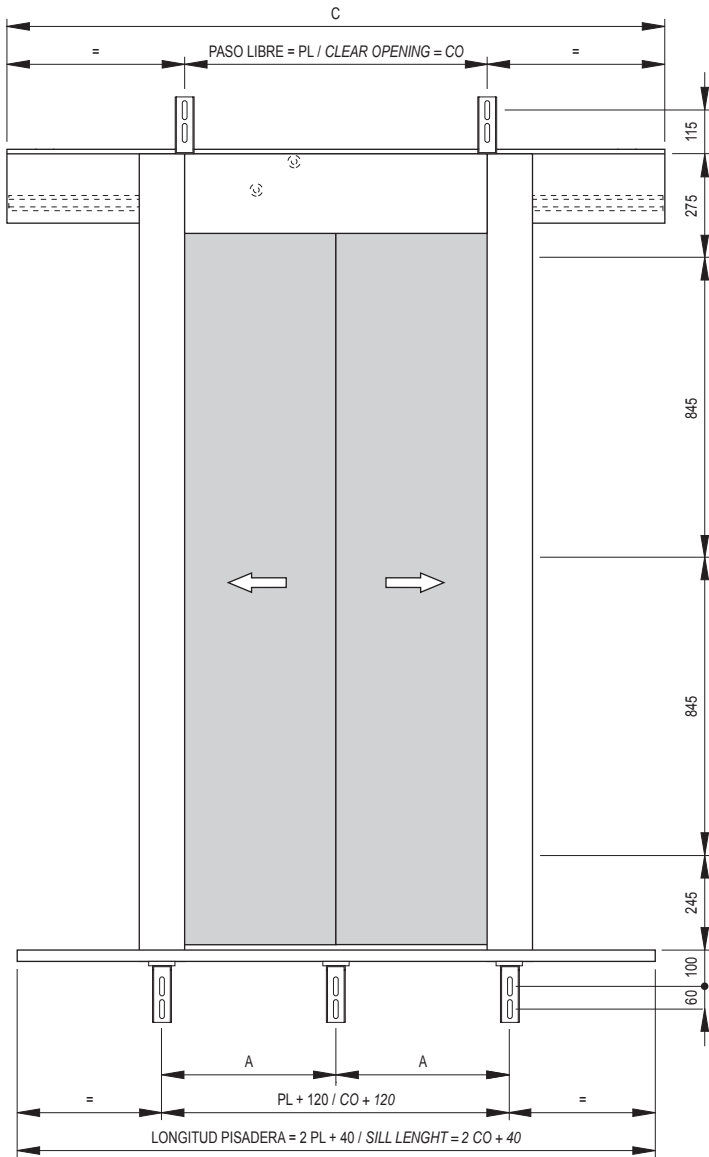

| PL / CO | 600 | 650 | 700 | 750 | 800 | 850 | 900 | 1000 | 1100 | 1200 | 1300 | 1400 | 1500 | 1600 | 1700 | 1800 | 1900 | 2000 |
|---------|------|------|------|------|------|------|------|------|------|------|------|------|------|------|------|------|------|------|
| C | 1300 | 1400 | 1500 | 1600 | 1700 | 1800 | 1900 | 2100 | 2300 | 2500 | 2700 | 2900 | 3100 | 3300 | 3500 | 3700 | 3900 | 4100 |
| A | 360 | 385 | 410 | 435 | 460 | 485 | 340 | 373 | 407 | 330 | 355 | 380 | 324 | 344 | 303 | 320 | 337 | 303 |
| S | 3 | 3 | 3 | 3 | 3 | 3 | 4 | 4 | 4 | 5 | 5 | 5 | 6 | 6 | 7 | 7 | 7 | 8 |
| T | 5 | 5 | 5 | 5 | 5 | 5 | 6 | 6 | 6 | 8 | 8 | 8 | 9 | 9 | 10 | 11 | 11 | 12 |

S: N°. de soportes en apoyo pisadera.
S: Number of supports for sill support.

T: N°. de soportes total.
T: Total number of supports.

Puerta con frontis
Door with infill panels

1

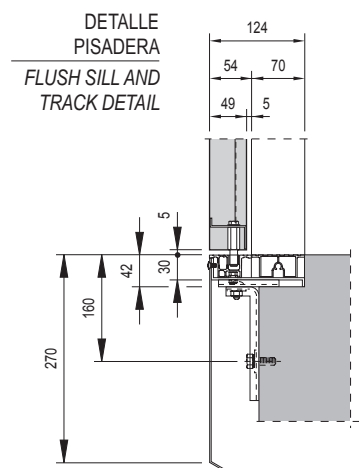
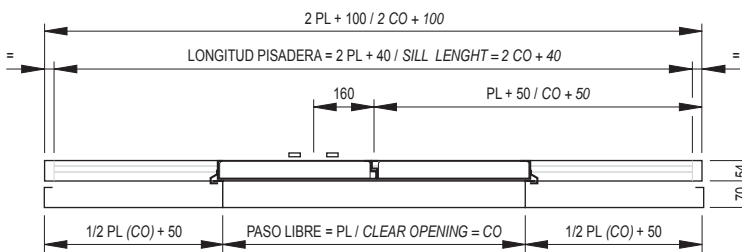
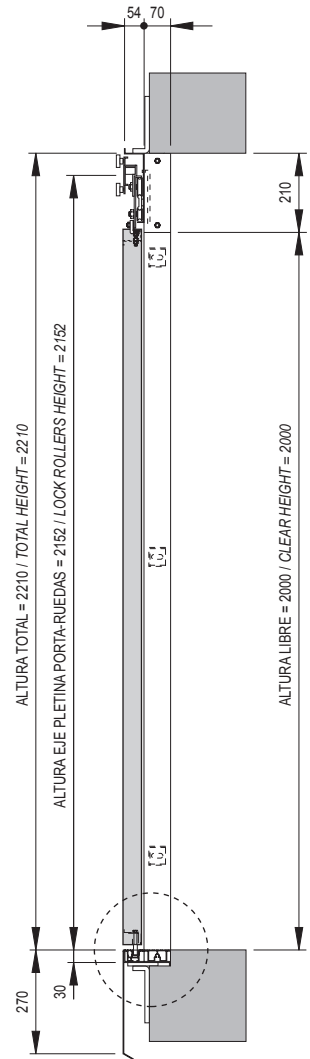
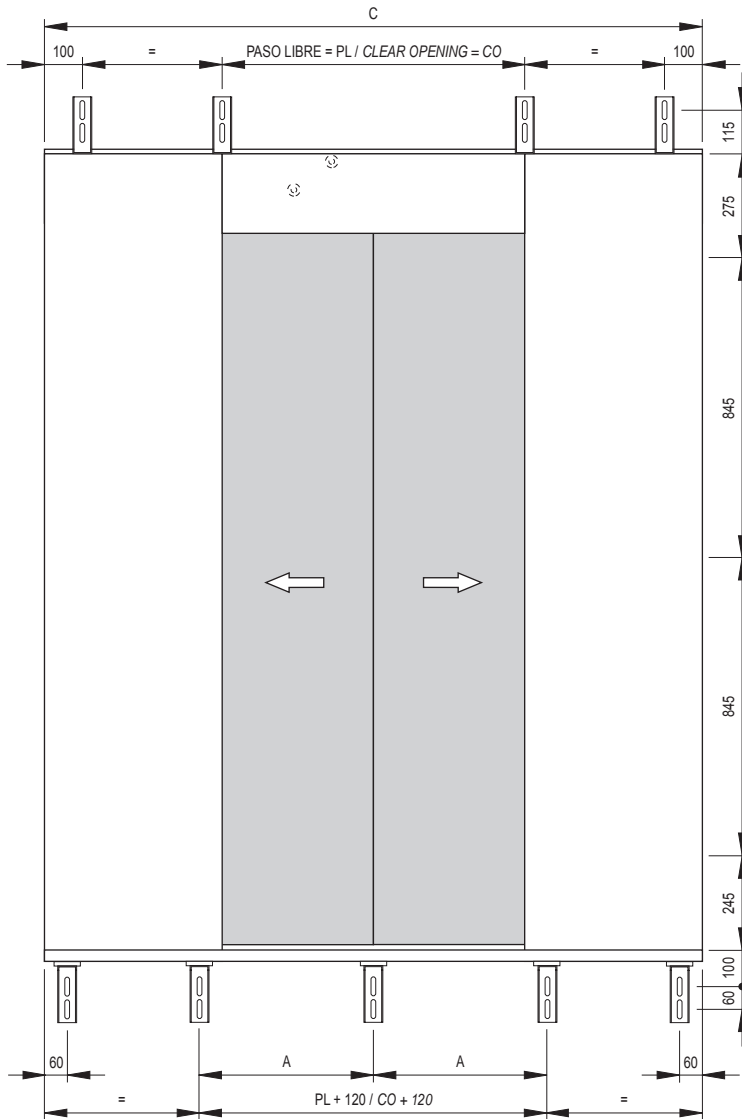

| PL / CO | 600 | 650 | 700 | 750 | 800 | 850 | 900 | 1000 | 1100 | 1200 | 1300 | 1400 | 1500 | 1600 | 1700 | 1800 | 1900 | 2000 |
|---------|------|------|------|------|------|------|------|------|------|------|------|------|------|------|------|------|------|------|
| C | 1300 | 1400 | 1500 | 1600 | 1700 | 1800 | 1900 | 2100 | 2300 | 2500 | 2700 | 2900 | 3100 | 3300 | 3500 | 3700 | 3900 | 4100 |
| A | 360 | 385 | 410 | 435 | 460 | 485 | 340 | 373 | 407 | 330 | 355 | 380 | 324 | 344 | 303 | 320 | 337 | 303 |
| S | 5 | 5 | 5 | 5 | 5 | 5 | 5 | 6 | 6 | 6 | 6 | 6 | 7 | 7 | 7 | 7 | 8 | 8 |
| T | 9 | 9 | 9 | 9 | 9 | 9 | 9 | 10 | 10 | 11 | 11 | 11 | 12 | 12 | 12 | 13 | 14 | 14 |

S: N°. de soportes en apoyo pisadera.
S: Number of supports for sill support.

T: N°. de soportes total.
T: Total number of supports.

1.4.

PUERTA RELLANO CENTRAL 2 HOJAS 2 PANEL CENTRE PARTING LANDING DOOR

40/10
DIN 18.091

Fermator
AUTOMATIC DOORS FOR LIFTS

1

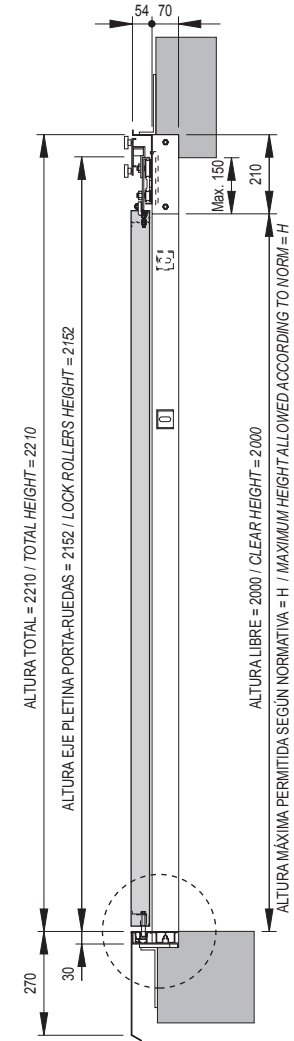
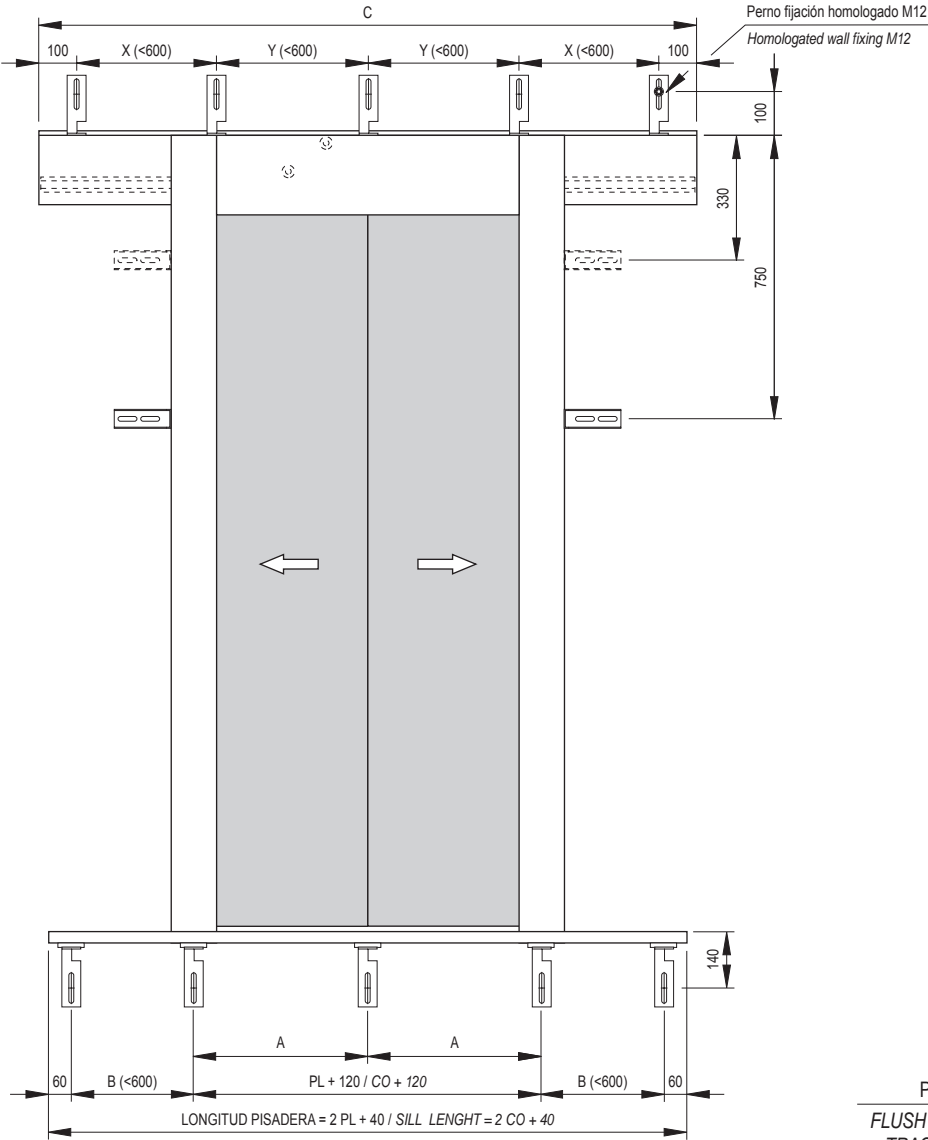

DETALLE PISADERA
FLUSH SILL AND TRACK DETAIL

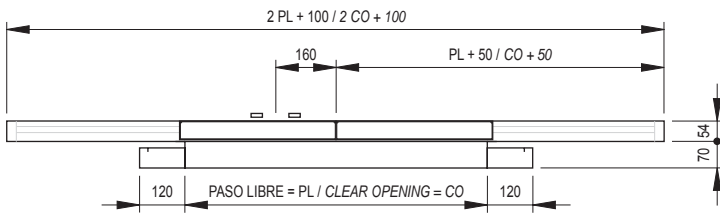
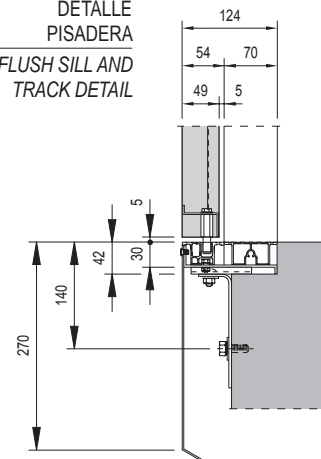

| PL / CO | 600 | 650 | 700 | 750 | 800 | 850 | 900 | 1000 | 1100 | 1200 | 1300 | 1400 | 1500 | 1600 | 1700 | 1800 | 1900 | 2000 | |
|---------|--------|-----|-----|-----|-----|-----|-----|------|------|------|------|------|------|------|------|------|------|------|--|
| A (mm) | 360 | 385 | 410 | 435 | 460 | 485 | 340 | 373 | 407 | 330 | 355 | 380 | 345 | 344 | 365 | 384 | 404 | 424 | |
| B (mm) | 290 | 255 | 280 | 305 | 330 | 355 | 380 | 430 | 480 | 530 | 580 | 315 | 340 | 365 | 390 | 415 | 440 | 465 | |
| X (mm) | 250 | 275 | 300 | 325 | 350 | 375 | 400 | 450 | 500 | 550 | 600 | 325 | 350 | 375 | 400 | 425 | 450 | 475 | |
| Y (mm) | 600 | 325 | 350 | 375 | 400 | 425 | 450 | 500 | 550 | 600 | 433 | 467 | 500 | 533 | 567 | 600 | 475 | 500 | |
| H | ≤ 2500 | | | | | | | | | | | | | - | | | | | |
| R | 4 | 5 | 5 | 5 | 5 | 5 | 5 | 5 | 5 | 5 | 6 | 8 | 8 | 8 | 8 | 8 | 9 | 9 | |
| S | 3 | 5 | 5 | 5 | 5 | 5 | 6 | 6 | 6 | 7 | 7 | 9 | 10 | 10 | 10 | 10 | 10 | 12 | |
| T | 9 | 12 | 12 | 12 | 12 | 12 | 13 | 13 | 13 | 14 | 15 | 19 | 20 | 20 | 20 | 20 | 21 | 23 | |

■ Puertas homologadas TÜV (DIN 18091).
■ Doors certified by TÜV (DIN 18091)

R: N° de soportes en mecanismo de rellano.
R: Number of supports for landing mechanism.

S: N° de soportes en apoyo pisadera.
S: Number of supports for sill support.

T: N° de soportes total.
T: Total number of supports.

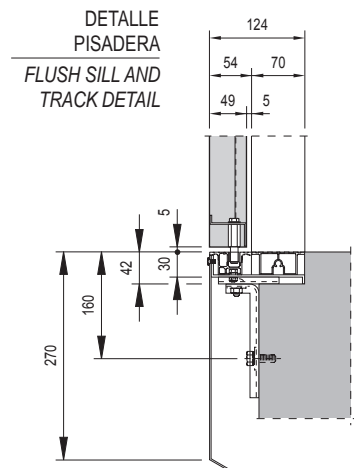
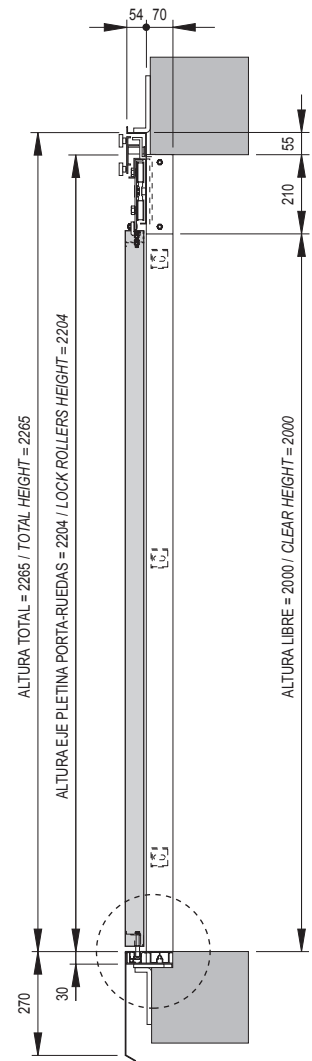
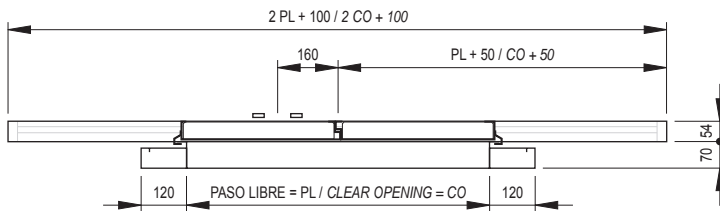
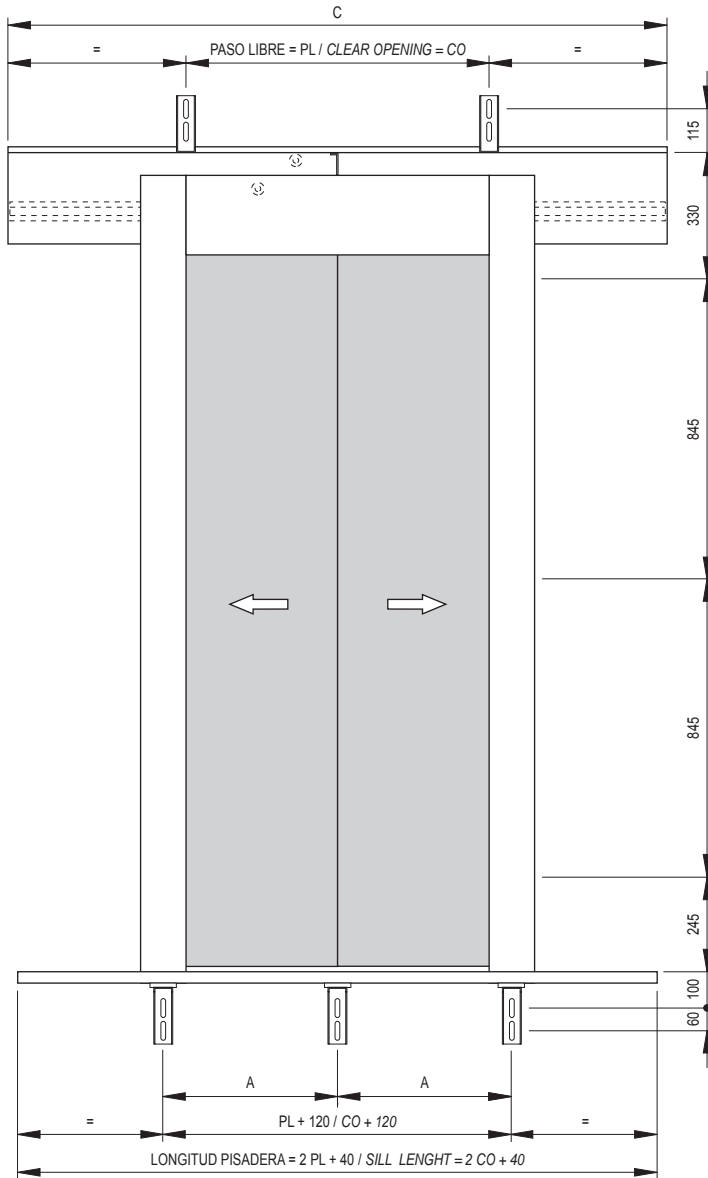

| PL / CO | 600 | 650 | 700 | 750 | 800 | 850 | 900 | 1000 | 1100 | 1200 | 1300 | 1400 | 1500 | 1600 | 1700 | 1800 | 1900 | 2000 |
|---------|------|------|------|------|------|------|------|------|------|------|------|------|------|------|------|------|------|------|
| C | 1300 | 1400 | 1500 | 1600 | 1700 | 1800 | 1900 | 2100 | 2300 | 2500 | 2700 | 2900 | 3100 | 3300 | 3500 | 3700 | 3900 | 4100 |
| A | 360 | 385 | 410 | 435 | 460 | 485 | 340 | 373 | 407 | 330 | 355 | 380 | 324 | 344 | 303 | 320 | 337 | 303 |
| S | 3 | 3 | 3 | 3 | 3 | 3 | 4 | 4 | 4 | 5 | 5 | 5 | 6 | 6 | 7 | 7 | 7 | 8 |
| T | 5 | 5 | 5 | 5 | 5 | 5 | 6 | 6 | 6 | 8 | 8 | 8 | 9 | 9 | 10 | 11 | 11 | 12 |

S: N°. de soportes en apoyo pisadera.
S: Number of supports for sill support.

T: N°. de soportes total.
T: Total number of supports.

1.6.

PUERTA RELLANO CENTRAL 2 HOJAS 2 PANEL CENTRE PARTING LANDING DOOR

50/11
DIN 18.091

Fermator
AUTOMATIC DOORS FOR LIFTS

1

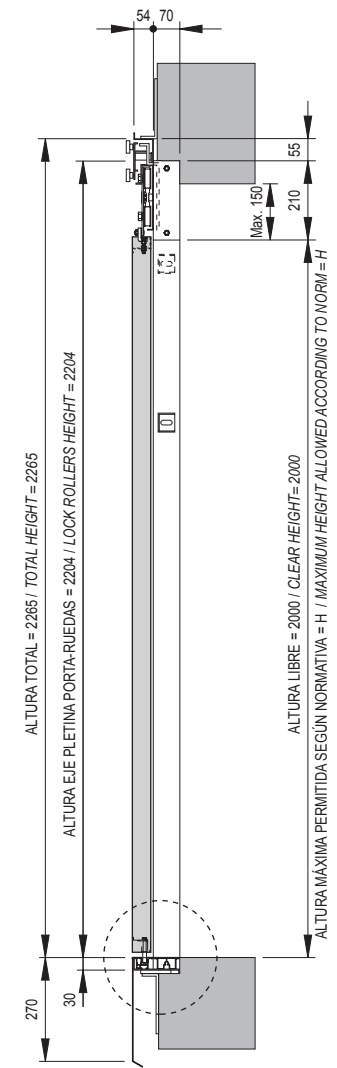
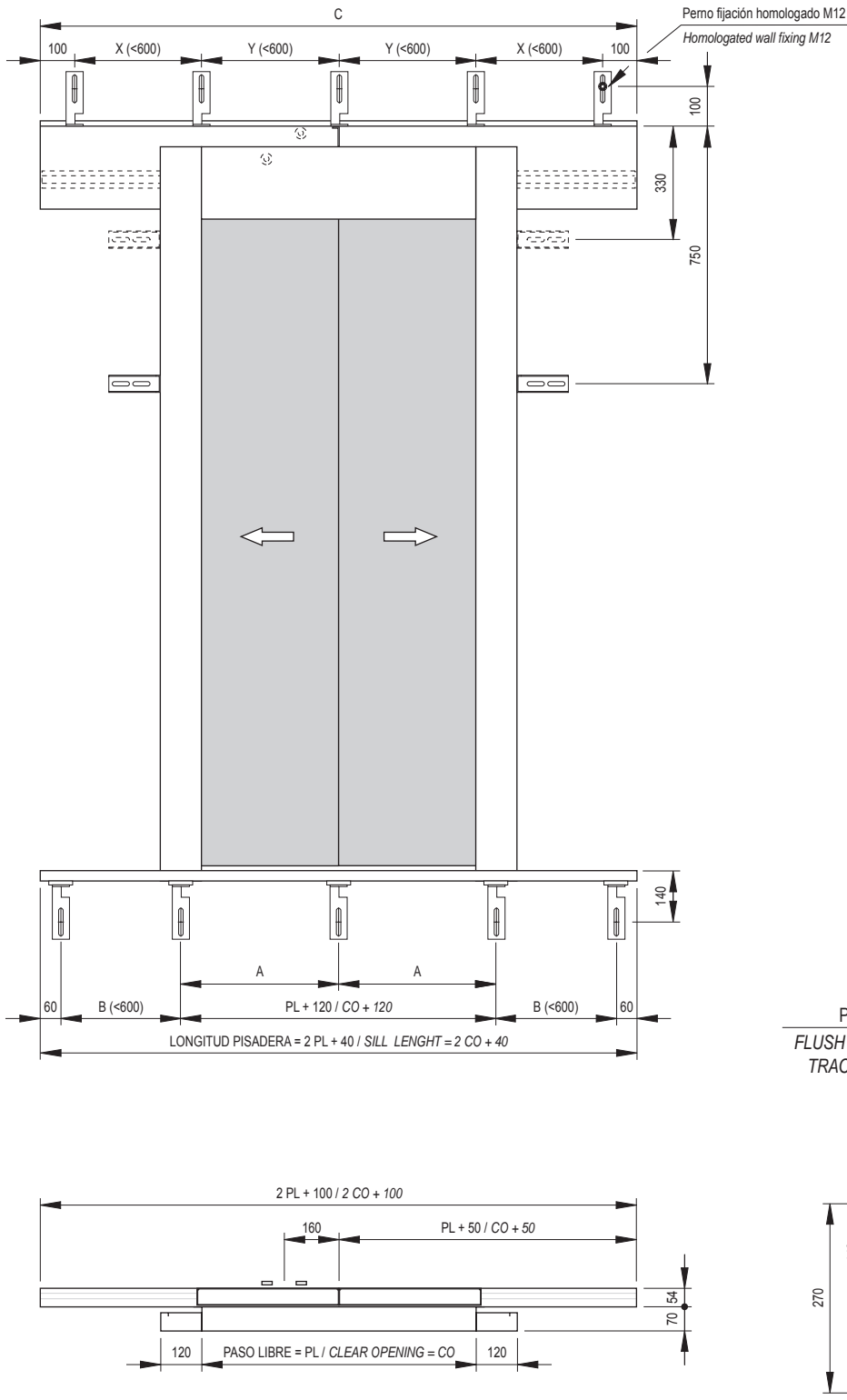

DETALLE
PISADERA
FLUSH SILL AND
TRACK DETAIL

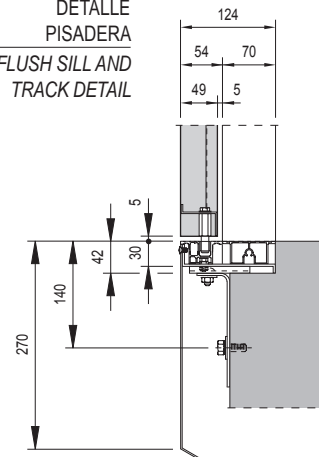

| PL / CO | 600 | 650 | 700 | 750 | 800 | 850 | 900 | 1000 | 1100 | 1200 | 1300 | 1400 | 1500 | 1600 | 1700 | 1800 | 1900 | 2000 | |
|---------|--------|-----|-----|-----|-----|-----|-----|------|------|------|------|------|------|------|------|------|------|------|--|
| A (mm) | 360 | 385 | 410 | 435 | 460 | 485 | 340 | 373 | 407 | 330 | 355 | 380 | 324 | 344 | 365 | 384 | 404 | 424 | |
| B (mm) | 290 | 255 | 280 | 305 | 330 | 355 | 380 | 430 | 480 | 530 | 580 | 315 | 340 | 365 | 390 | 415 | 440 | 465 | |
| X (mm) | 250 | 275 | 300 | 325 | 350 | 375 | 400 | 450 | 500 | 550 | 600 | 325 | 350 | 375 | 400 | 425 | 450 | 475 | |
| Y (mm) | 600 | 325 | 350 | 375 | 400 | 425 | 450 | 500 | 550 | 600 | 433 | 467 | 500 | 533 | 567 | 600 | 475 | 500 | |
| H | ≤ 2500 | | | | | | | | | | | | | | | - | | | |
| R | 4 | 5 | 5 | 5 | 5 | 5 | 5 | 5 | 5 | 5 | 6 | 8 | 8 | 8 | 8 | 8 | 9 | 9 | |
| S | 3 | 5 | 5 | 5 | 5 | 5 | 6 | 6 | 6 | 7 | 7 | 9 | 10 | 10 | 10 | 10 | 10 | 12 | |
| T | 9 | 12 | 12 | 12 | 12 | 12 | 13 | 13 | 13 | 14 | 15 | 19 | 20 | 20 | 20 | 20 | 21 | 23 | |

Puertas homologadas TÜV (DIN 18091). R: N° de soportes en mecanismo de rellano. S: N° de soportes en apoyo pisadera. T: N° de soportes total.
 Doors certified by TÜV (DIN 18091). R: Number of supports for landing mechanism. S: Number of supports for sill support. T: Total number of supports.

Puerta de rellano central 2 hojas modelo 40/10
2 panel centre landing door model 40/10

1

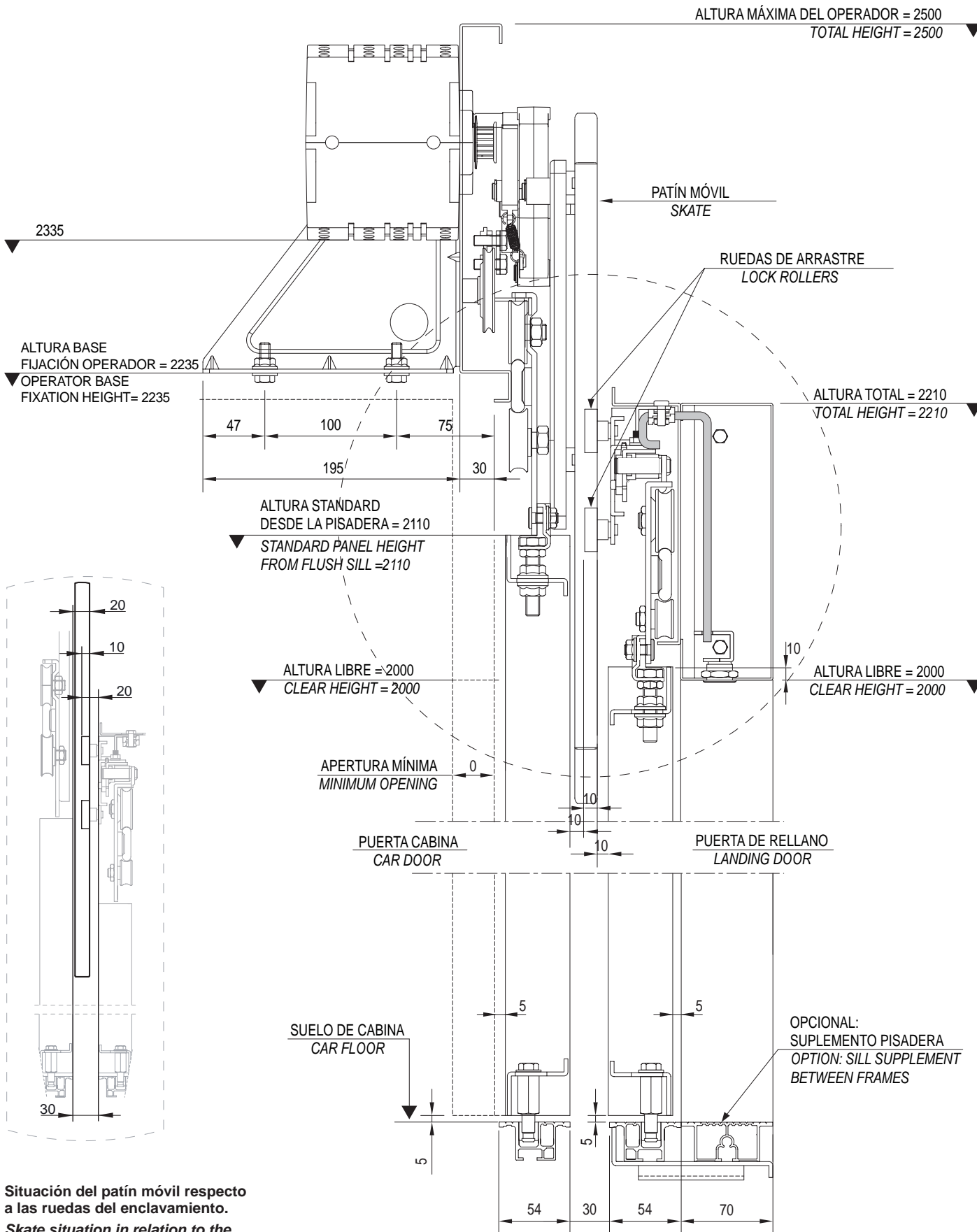

Situación del patín móvil respecto a las ruedas del enclavamiento.
Skate situation in relation to the locking device rollers.

1.8.

SITUACIÓN DEL PATÍN CON LAS RUEDAS DE ARRASTE COUPLING ARRANGEMENT BETWEEN SKATE AND LOCK

fermator
AUTOMATIC DOORS FOR LIFTS

Puerta de rellano central 2 hojas modelo 50/11
2 panel centre parting landing door model 50/11

1

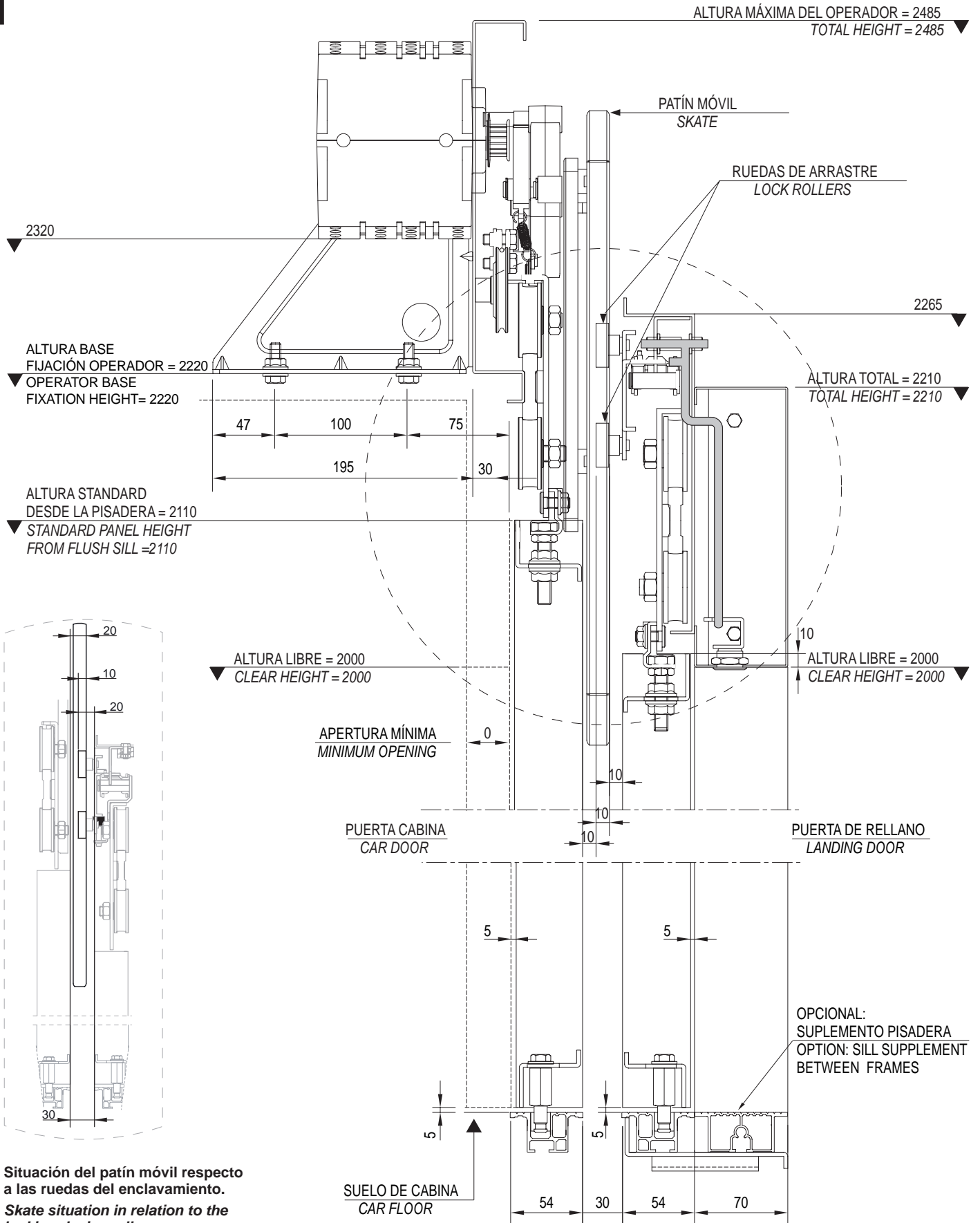

Situación del patín móvil respecto a las ruedas del enclavamiento.
Skate situation in relation to the locking device rollers.

Ferrotec

AUTOMATIC DOORS FOR LIFTS

PUERTA CENTRAL DE 4 HOJAS
4 PANEL CENTRE PARTING DOOR

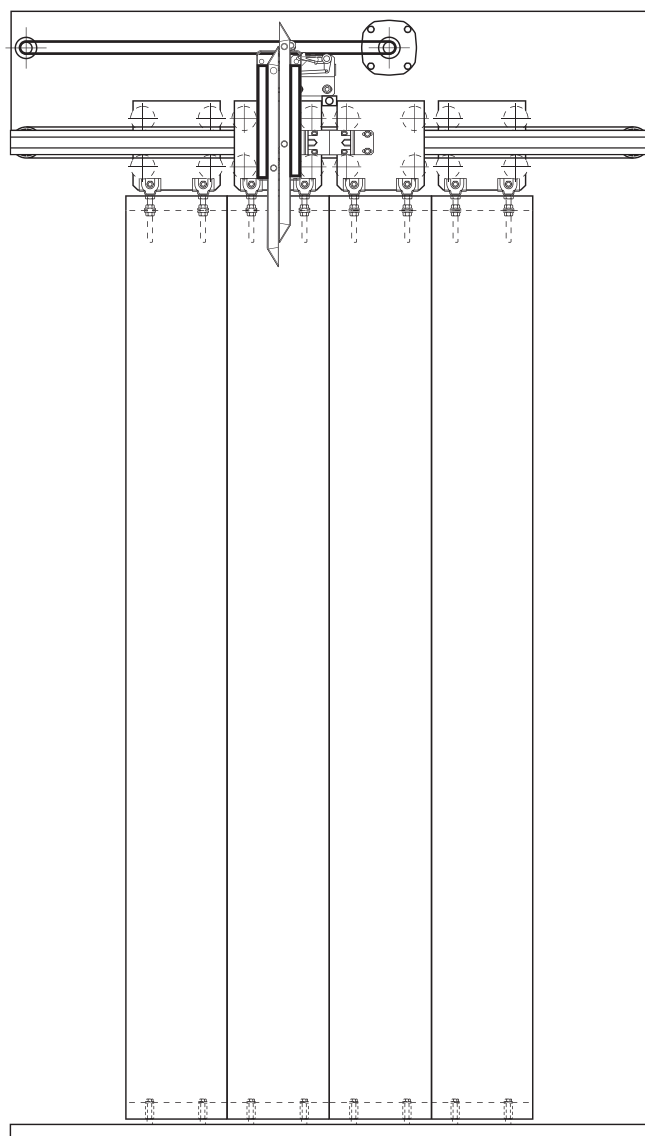

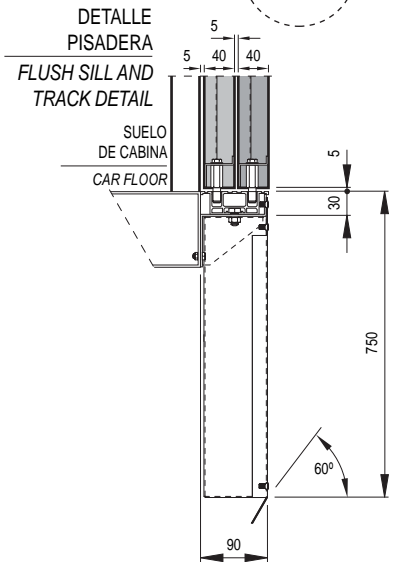
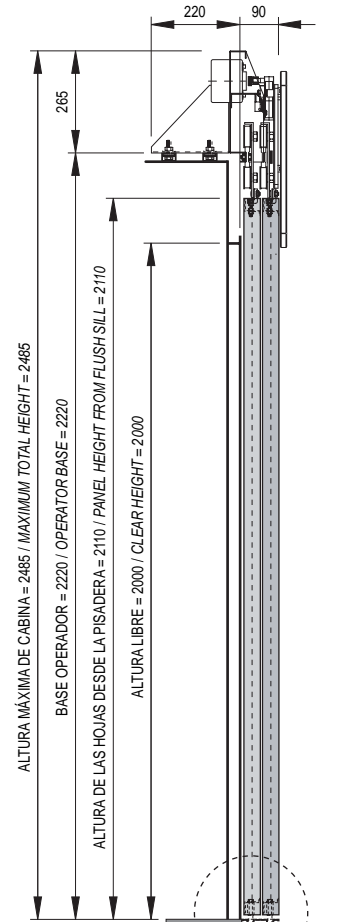
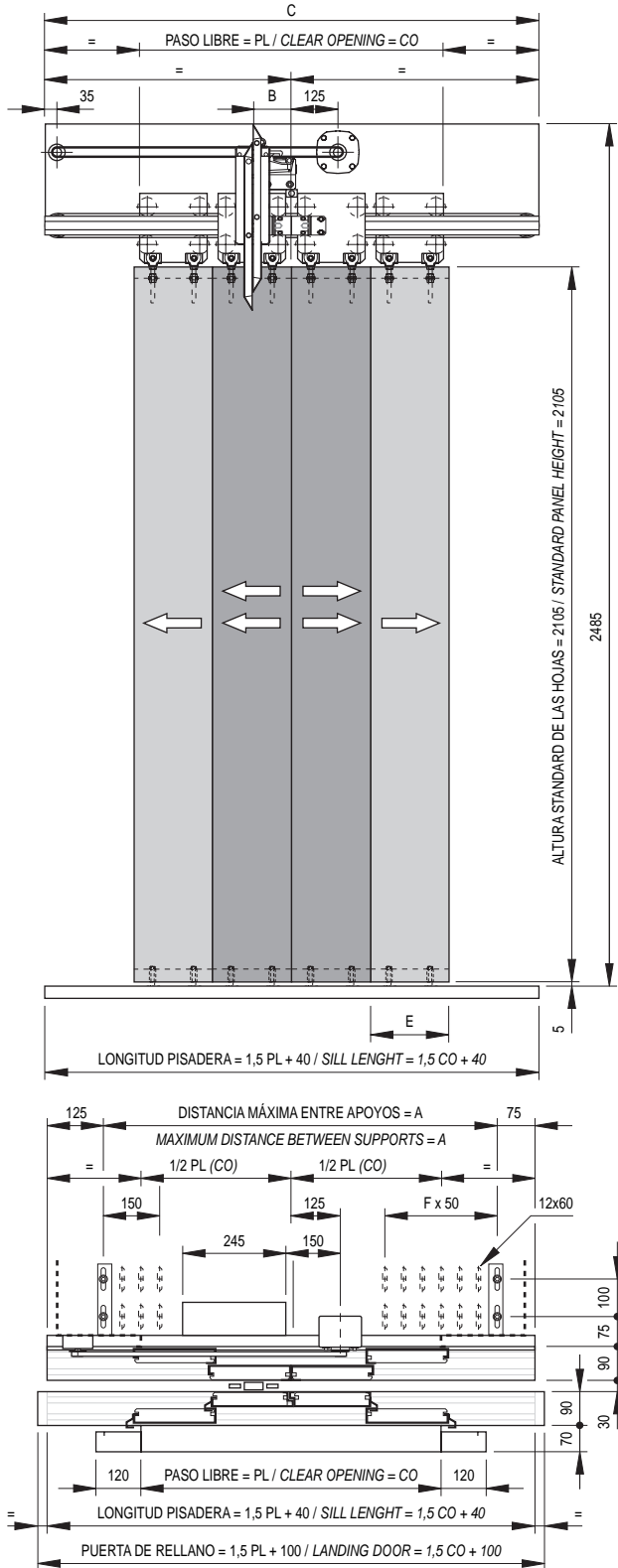

| PL / CO | Un Motor / One Motor | | | | | | |
|--------------------|----------------------|-------|------|-------|------|------|-------|
| | 600 | 650 | 700 | 750 | 800 | 900 | 1000 |
| A | 750 | 825 | 900 | 975 | 1050 | 1200 | 1350 |
| B | 100 | 100 | 100 | 100 | 100 | 100 | 160 |
| C | 980 | 1025 | 1100 | 1175 | 1250 | 1400 | 1550 |
| E | 170 | 182,5 | 195 | 207,5 | 220 | 245 | 270 |
| F | 4 | 4 | 5 | 5 | 6 | 6 | 7 |
| TIEMPO / TIME (s) | 1,22 | 1,27 | 1,32 | 1,37 | 1,41 | 1,5 | 1,58 |
| PESO / WEIGHT (Kg) | 61,5 | 67 | 72 | 77 | 82 | 92,5 | 102,5 |

2.2.

PUERTA CABINA CENTRAL 4 HOJAS 4 PANEL CENTRE PARTING CAR DOOR

VVVF

fermator
AUTOMATIC DOORS FOR LIFTS

2

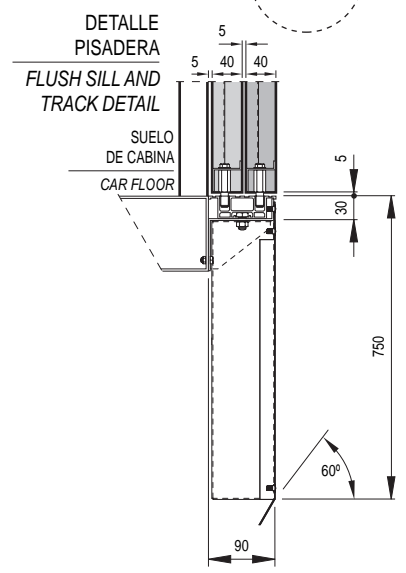
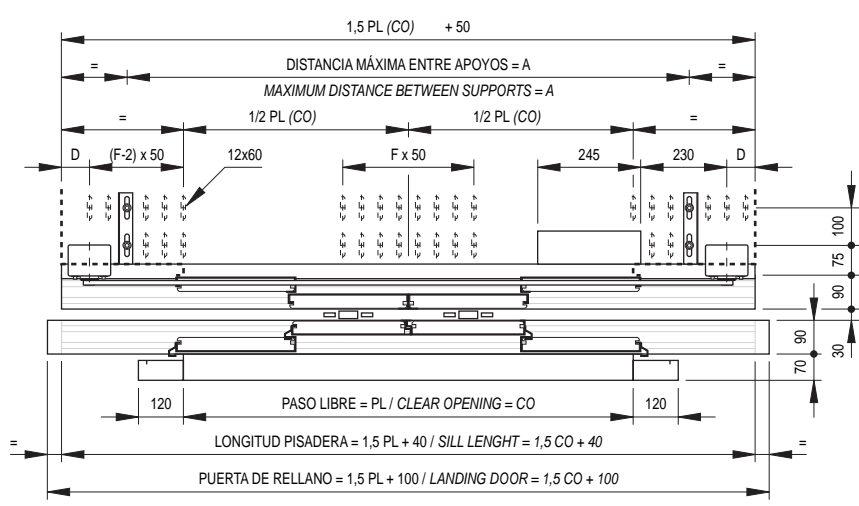
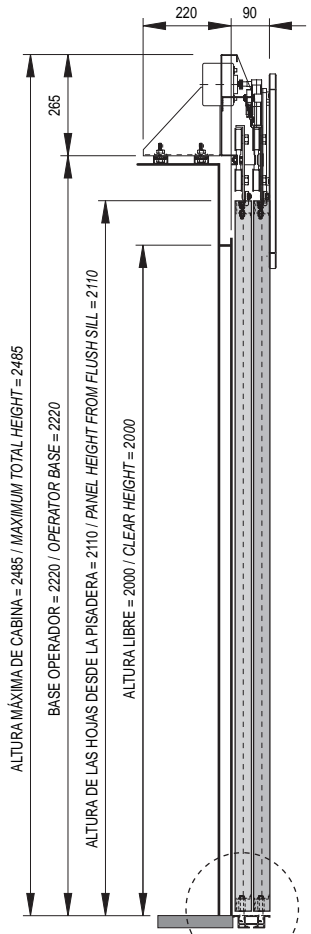
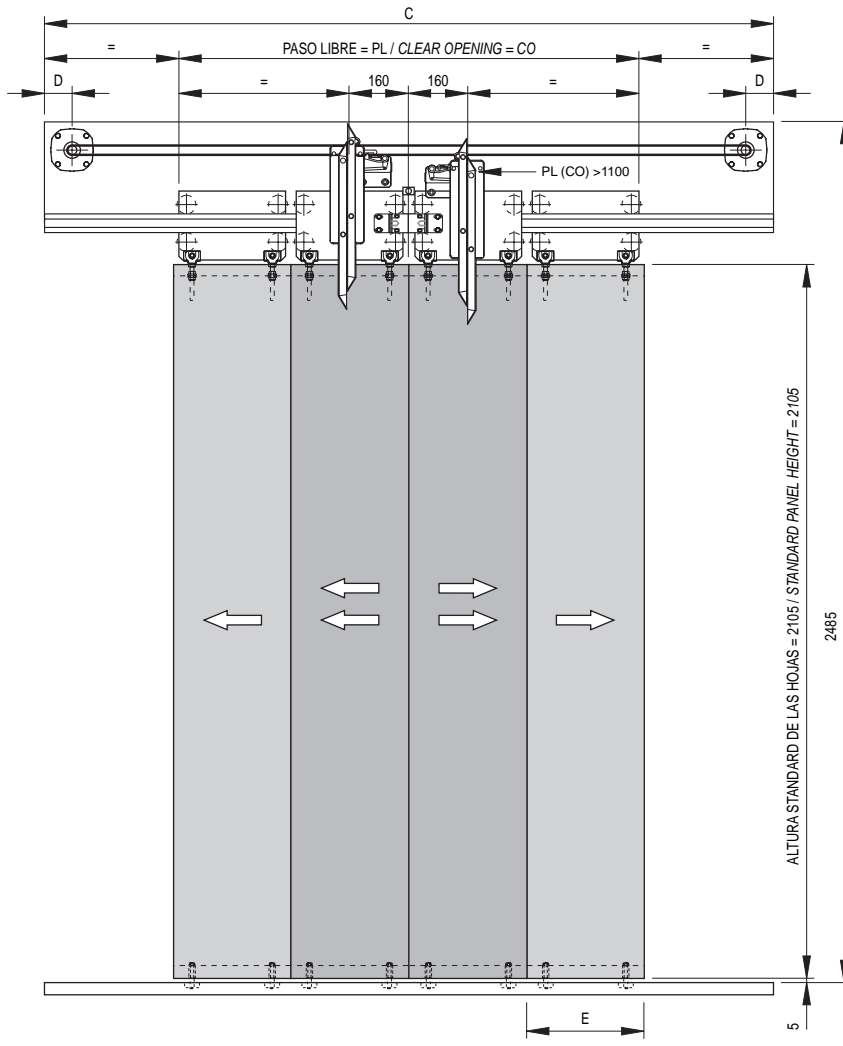

| PATINES / SKATE | Dos Motores / Two Motors | | | | | | | | | | | | | | | | | | | |
|--------------------|--------------------------|------|-------|-------|------|------|-------|-------|------|------|-------|-------|------|------|-------|-------|------|------|-------|-------|
| | 1 | 2 | | | | | | | | | | | | | | | | | | |
| PL / CO | 1100 | 1200 | 1300 | 1400 | 1500 | 1600 | 1700 | 1800 | 1900 | 2000 | 2100 | 2200 | 2300 | 2400 | 2500 | 2600 | 2700 | 2800 | 2900 | 3000 |
| A | 1500 | 1400 | 1550 | 1700 | 1850 | 2000 | 2150 | 2300 | 2450 | 2600 | 2750 | 2900 | 3050 | 3200 | 3350 | 3500 | 3650 | 3800 | 3950 | 4100 |
| C | 1700 | 1850 | 2000 | 2150 | 2300 | 2450 | 2600 | 2750 | 2900 | 3050 | 3200 | 3350 | 3500 | 3650 | 3800 | 3950 | 4100 | 4250 | 4400 | 4550 |
| D | 88 | 88 | 88 | 125 | 125 | 125 | 175 | 175 | 225 | 225 | 277 | 277 | 325 | 325 | 375 | 375 | 425 | 425 | 475 | 475 |
| E | 295 | 320 | 345 | 370 | 395 | 420 | 445 | 470 | 495 | 520 | 545 | 570 | 595 | 620 | 645 | 670 | 695 | 720 | 745 | 770 |
| F | 4 | 4 | 4 | 4 | 4 | 5 | 5 | 5 | 5 | 5 | 5 | 5 | 5 | 5 | 5 | 5 | 5 | 5 | 5 | 5 |
| TIEMPO / TIME (s) | 1,66 | 1,73 | 1,8 | 1,87 | 1,94 | 2 | 2,06 | 2,12 | 2,18 | 2,24 | 2,29 | 2,35 | 2,4 | 2,45 | 2,5 | 2,55 | 2,6 | 2,65 | 2,7 | 2,75 |
| PESO / WEIGHT (kg) | 113 | 123 | 133,5 | 143,5 | 154 | 164 | 174,5 | 184,5 | 195 | 205 | 215,5 | 225,5 | 236 | 246 | 256,5 | 266,5 | 277 | 287 | 297,5 | 307,5 |

Puerta con un enclavamiento
Door with one locking device

*: EN POSICIÓN DE PUERTA ABIERTA, EL ENCLAVAMIENTO SOBRESALE 40 mm EN PL 600 Y 15 mm EN PL 700.
*: IN OPEN DOOR POSITION, THE LOCKING DEVICE STICKS OUT 40 mm IN CO 600 AND 15 mm IN CO 700.

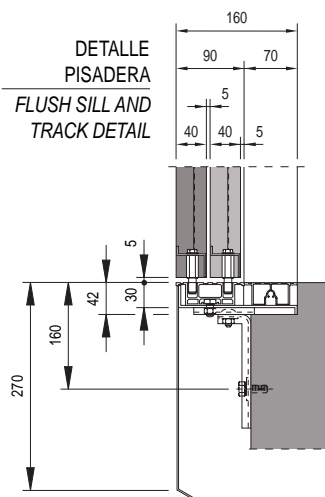
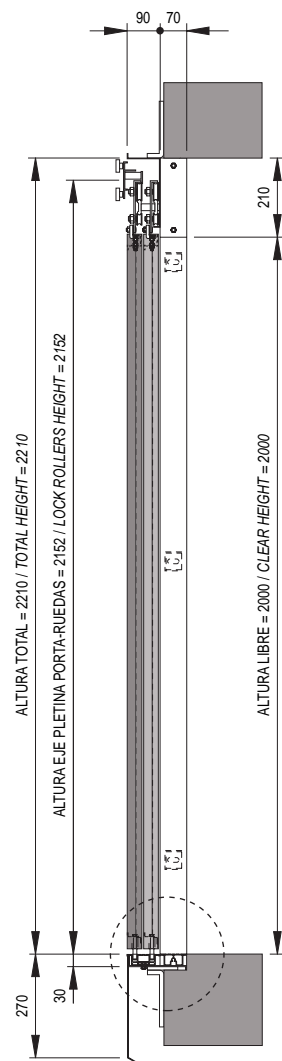
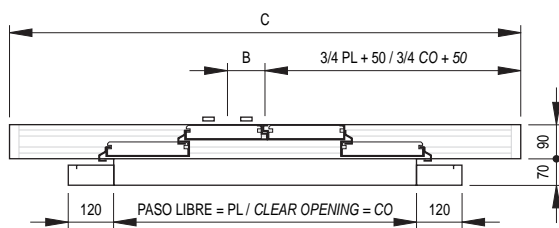
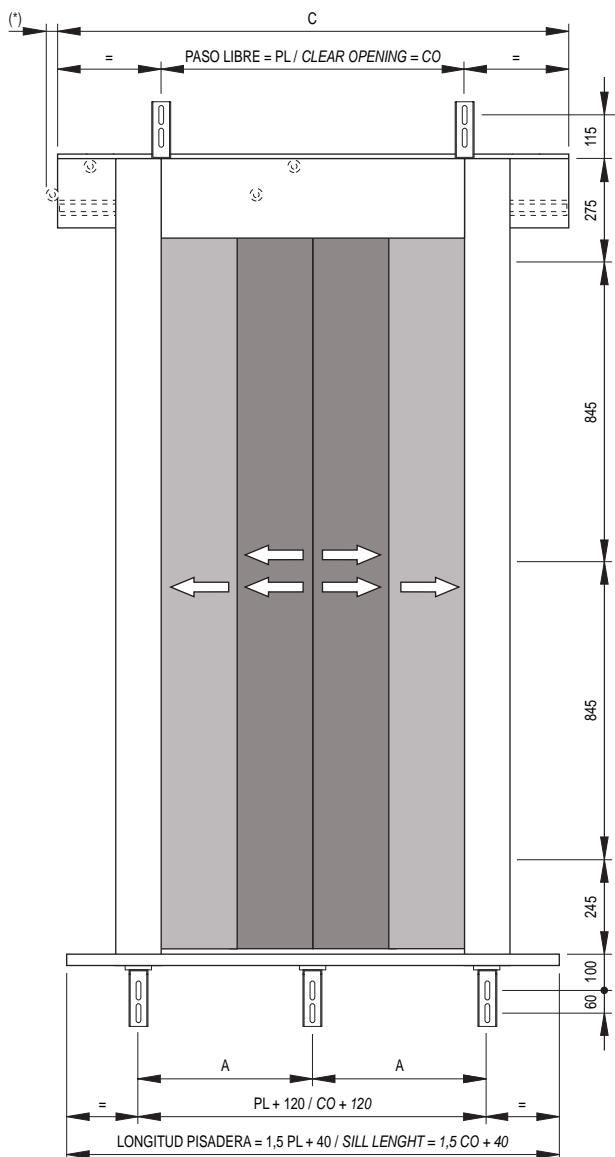

| PL / CO | 600 | 650 | 700 | 750 | 800 | 900 | 1000 | 1100 |
|---------|------|------|------|------|------|------|------|------|
| A | 360 | 385 | 410 | 435 | 460 | 340 | 373 | 407 |
| B | 100 | 100 | 100 | 100 | 100 | 100 | 160 | 160 |
| C | 1000 | 1075 | 1150 | 1225 | 1300 | 1450 | 1600 | 1750 |
| S | 3 | 3 | 3 | 3 | 3 | 4 | 4 | 4 |
| T | 5 | 5 | 5 | 5 | 5 | 6 | 6 | 6 |

S: N° de soportes en apoyo pisadera.
S: Number of supports for sill support.

T: N° de soportes total.
T: Total number of supports.

Puerta con doble enclavamiento
Door with two locking device

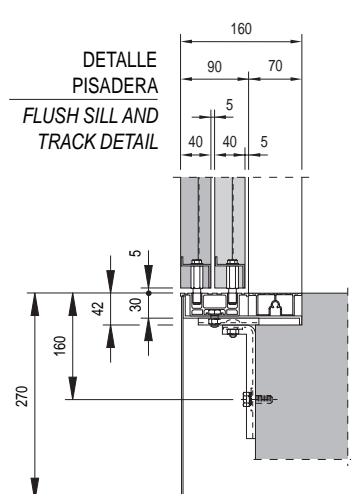
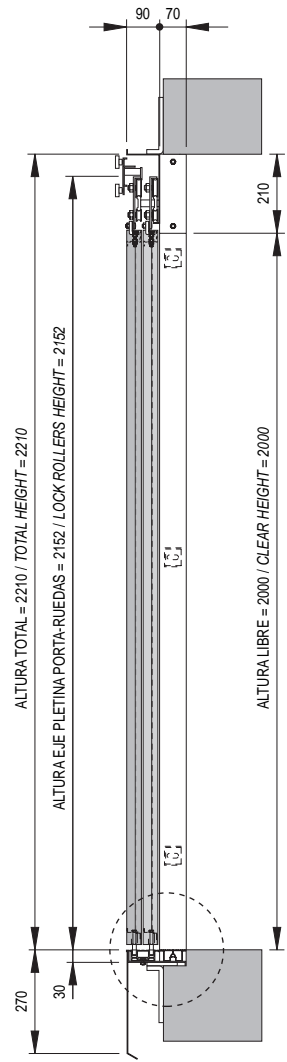
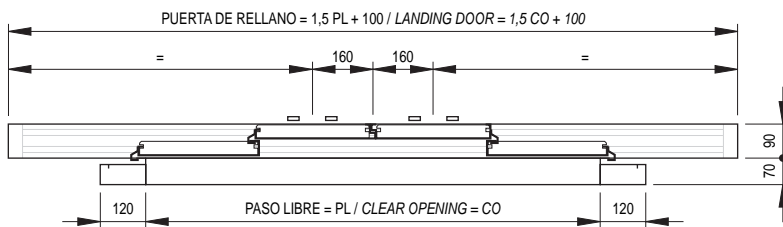
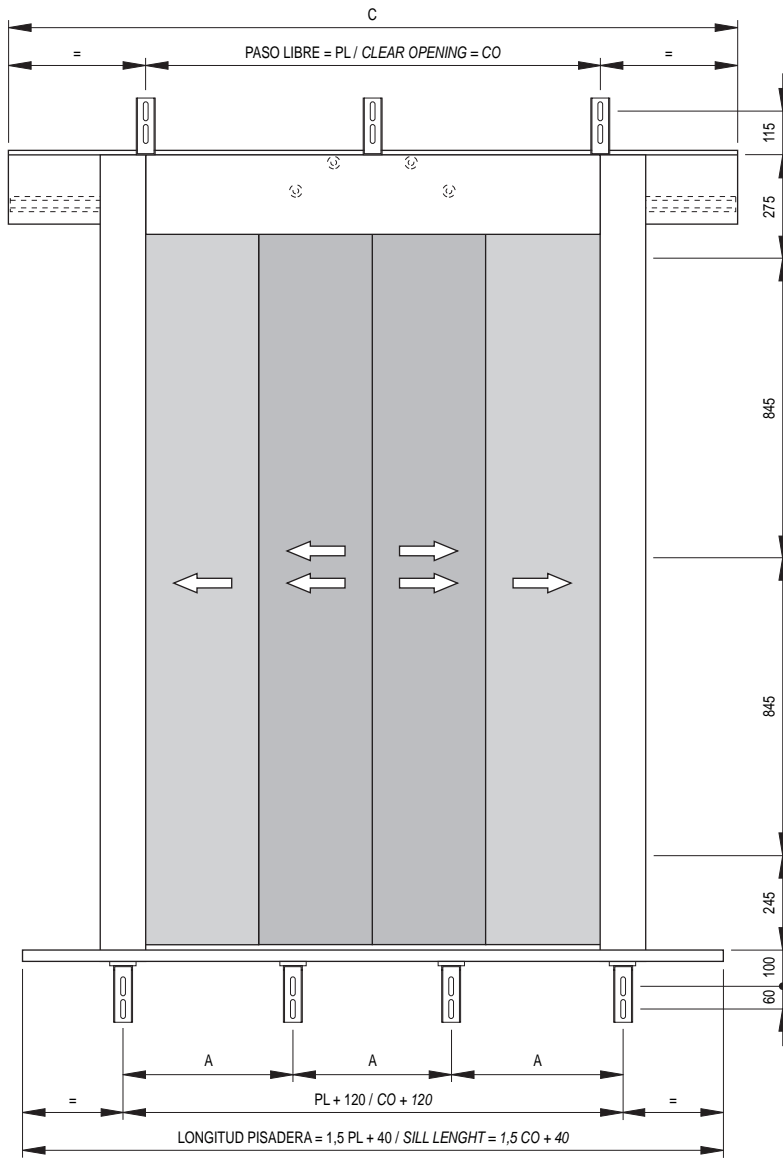

| TB / PL | 1200 | 1300 | 1400 | 1500 | 1600 | 1700 | 1800 | 1900 | 2000 | 2100 | 2200 | 2300 | 2400 |
|---------|------|------|------|------|------|------|------|------|------|------|------|------|------|
| A | 330 | 355 | 380 | 324 | 344 | 364 | 384 | 404 | 353 | 370 | 387 | 403 | 360 |
| C | 1900 | 2050 | 2200 | 2350 | 2500 | 2650 | 2800 | 2950 | 3100 | 3250 | 3400 | 3550 | 3700 |
| S | 5 | 5 | 5 | 6 | 6 | 7 | 7 | 7 | 8 | 8 | 8 | 9 | 9 |
| T | 8 | 9 | 9 | 10 | 10 | 11 | 12 | 12 | 14 | 14 | 14 | 15 | 16 |

S: N° de soportes en apoyo pisadera.
S: Number of supports for sill support.

T: N° de soportes total.
T: Total number of supports.

Door with infill panels and one locking device

*: EN POSICIÓN DE PUERTA ABIERTA, EL ENCLAVAMIENTO SOBRESALE 40 mm EN PL 600 Y 15 mm EN PL 700.
*: IN OPEN DOOR POSITION, THE LOCKING DEVICE STICKS OUT 40 mm IN CO 600 AND 15 mm IN CO 700.

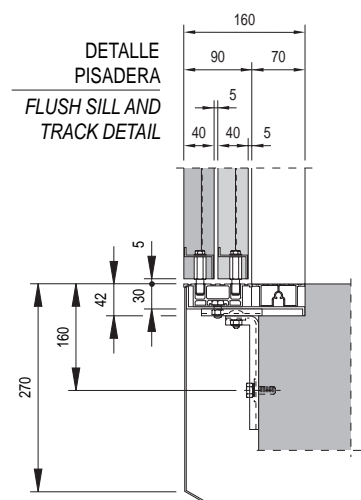
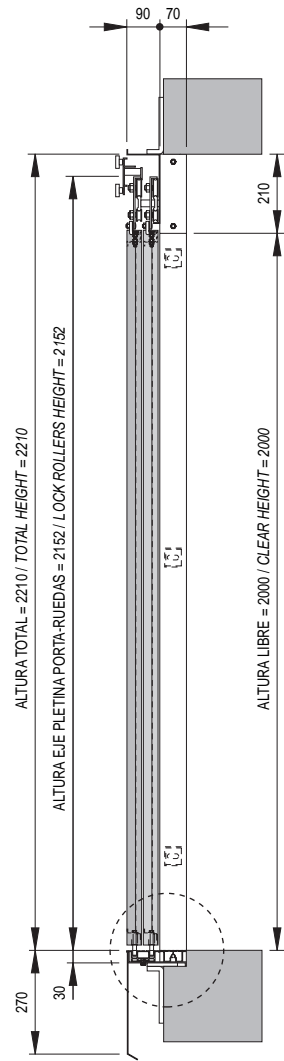
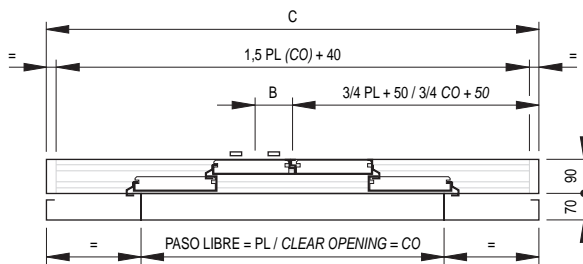
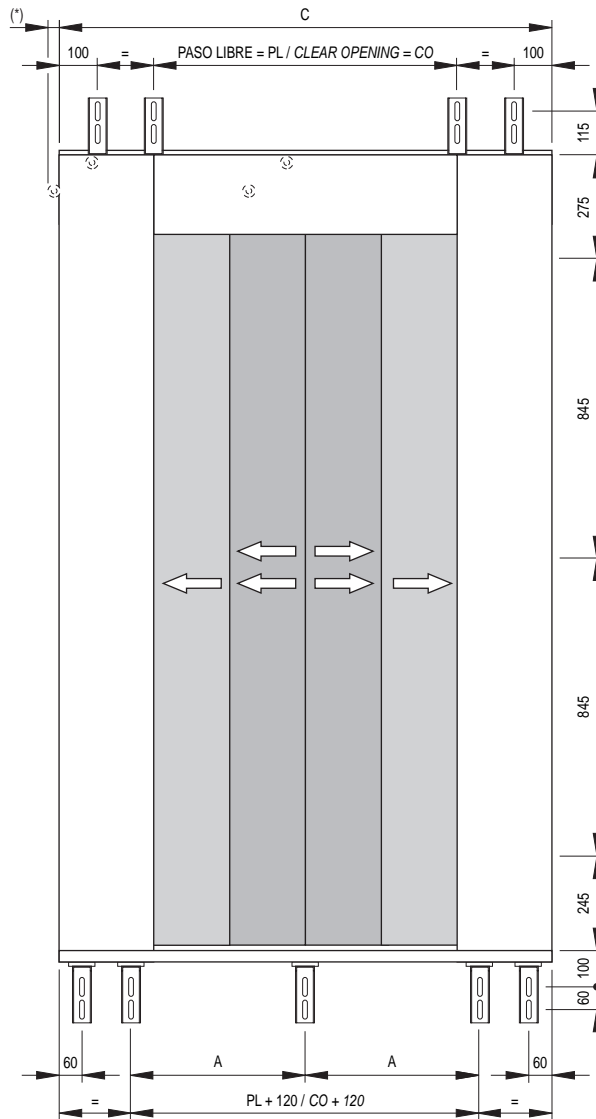

| PL / CO | 600 | 650 | 700 | 750 | 800 | 900 | 1000 | 1100 |
|---------|------|------|------|------|------|------|------|------|
| A | 360 | 385 | 410 | 435 | 460 | 340 | 373 | 407 |
| B | 100 | 100 | 100 | 100 | 100 | 100 | 160 | 160 |
| C | 1000 | 1075 | 1150 | 1225 | 1300 | 1450 | 1600 | 1750 |
| S | 5 | 5 | 5 | 5 | 5 | 6 | 6 | 7 |
| T | 9 | 9 | 9 | 9 | 9 | 10 | 10 | 11 |

S: N°. de soportes en apoyo pisadera.
S: Number of supports for sill support.

T: N°. de soportes total.
T: Total number of supports.

2.6.

PUERTA RELLANO CENTRAL 4 HOJAS 4 PANEL CENTRE PARTING LANDING DOOR

40/10

Fermator
AUTOMATIC DOORS FOR LIFTS

Puerta con frontis y doble enclavamiento
Door with infill panels and two locking devices

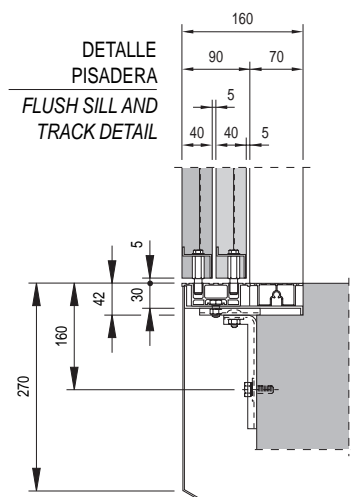
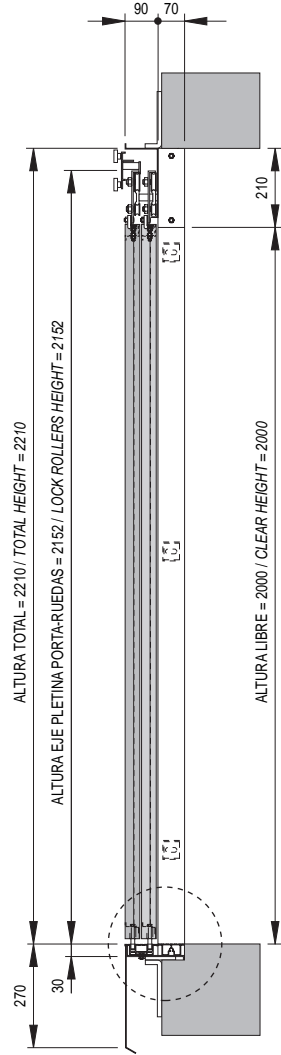
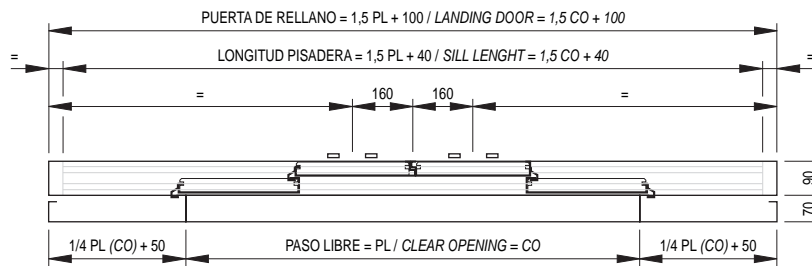
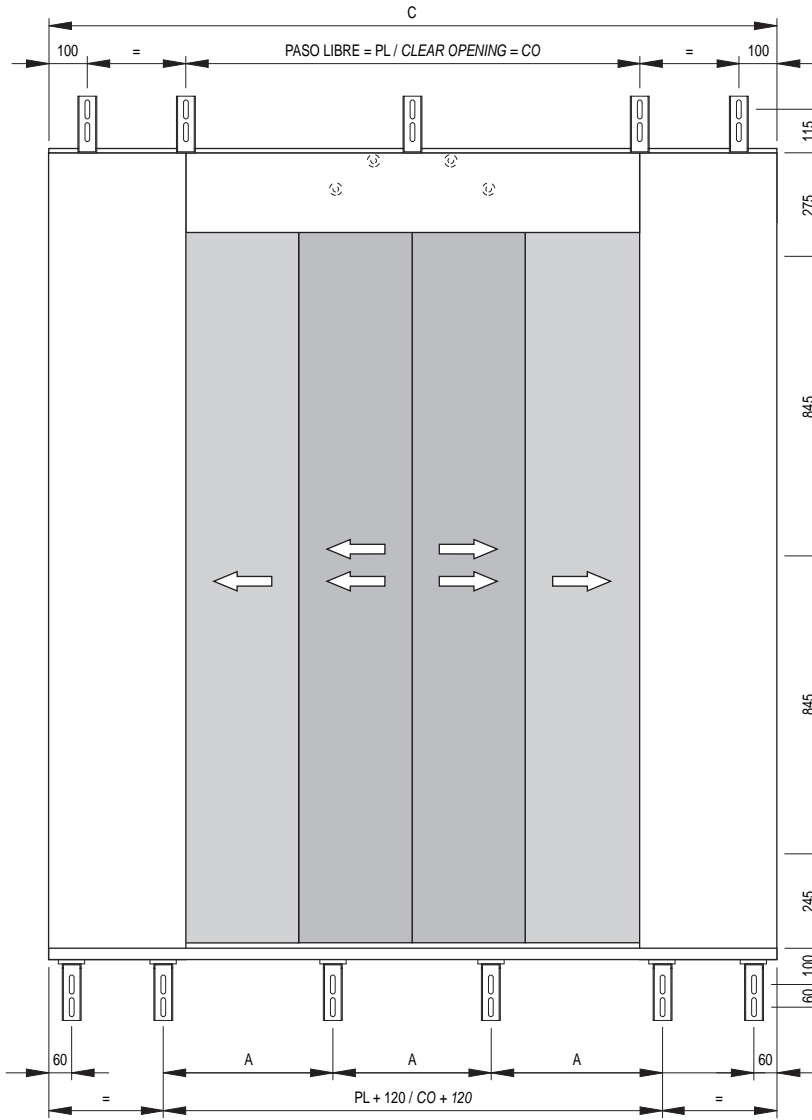

| PL / CO | 1200 | 1300 | 1400 | 1500 | 1600 | 1700 | 1800 | 1900 | 2000 | 2100 | 2200 | 2300 | 2400 |
|---------|------|------|------|------|------|------|------|------|------|------|------|------|------|
| A | 330 | 355 | 380 | 324 | 344 | 364 | 384 | 404 | 353 | 370 | 387 | 403 | 360 |
| C | 1900 | 2050 | 2200 | 2350 | 2500 | 2650 | 2800 | 2950 | 3100 | 3250 | 3400 | 3550 | 3700 |
| S | 7 | 7 | 8 | 8 | 8 | 9 | 9 | 9 | 10 | 10 | 10 | 11 | 11 |
| T | 12 | 12 | 13 | 13 | 13 | 14 | 15 | 15 | 16 | 16 | 16 | 16 | 17 |

S: N^o. de soportes en apoyo pisadera.
S: Number of supports for sill support.

T: N^o. de soportes total.
T: Total number of supports.

*: EN POSICIÓN DE PUERTA ABIERTA, EL ENCLAVAMIENTO SOBRESALE 40 mm EN PL 600 Y 15 mm EN PL 700.
*: IN OPEN DOOR POSITION, THE LOCKING DEVICE STICKS OUT 40 mm IN CO 600 AND 15 mm IN CO 700.

Puerta con un enclavamiento
Door with one locking device

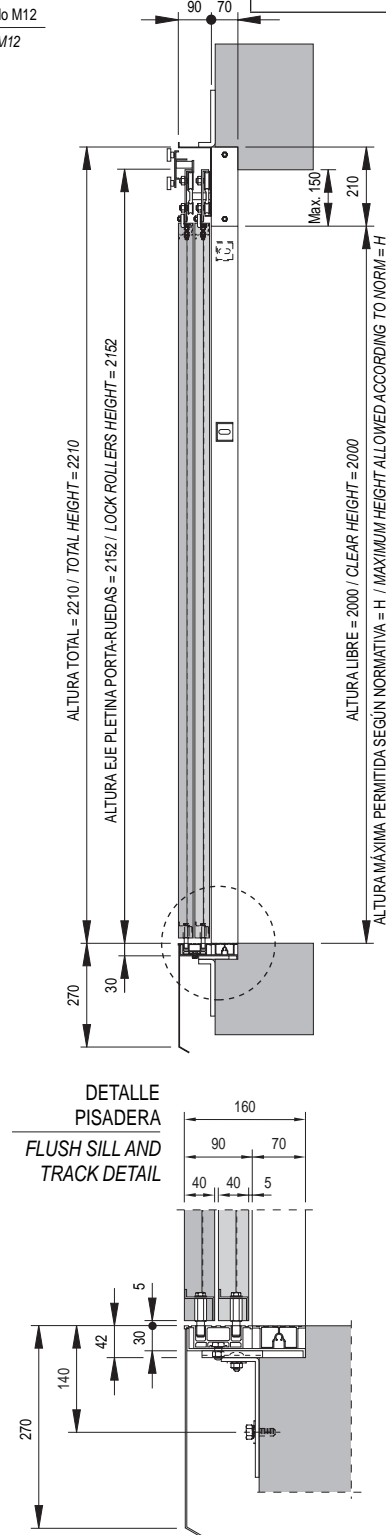
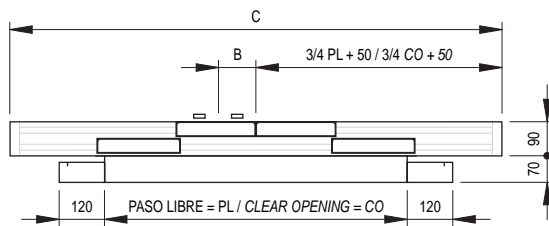
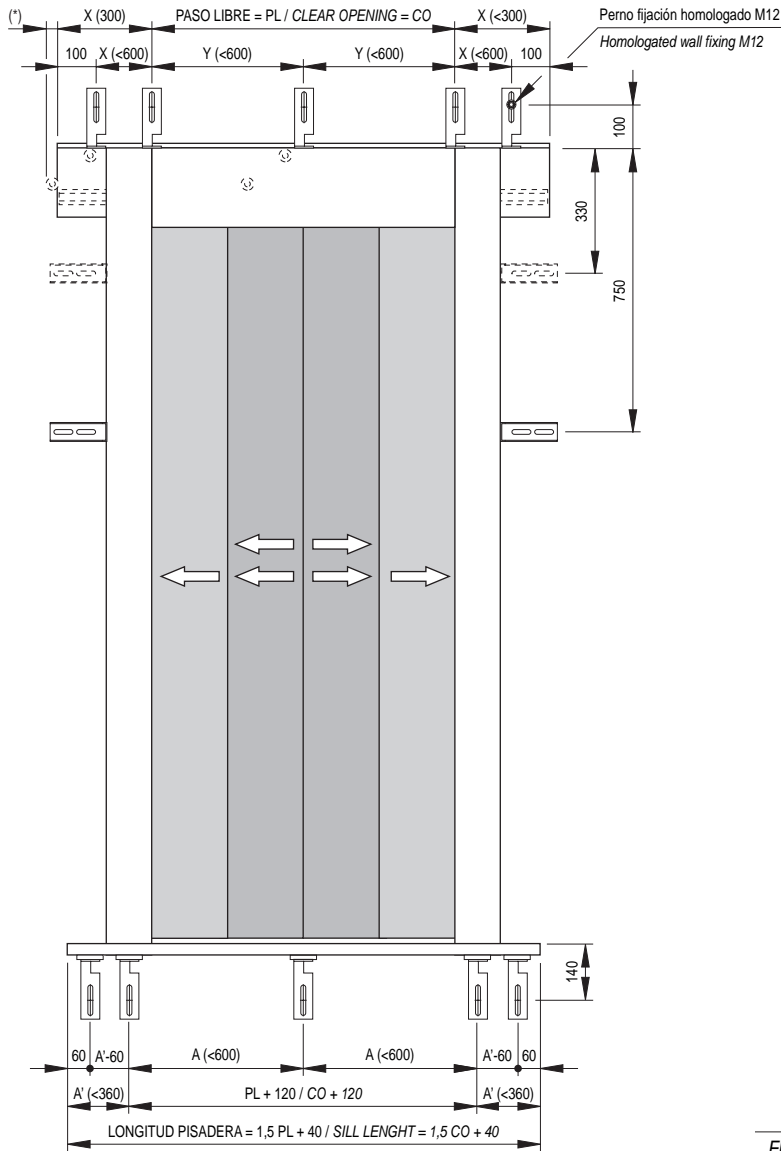

| PL / CO | 600 | 650 | 700 | 750 | 800 | 900 | 1000 | 1100 |
|---------|-------|------|------|------|------|------|------|------|
| A | 360 | 385 | 410 | 435 | 460 | 340 | 373 | 407 |
| A' | 140 | 152 | 165 | 177 | 190 | 215 | 240 | 265 |
| B | 100 | 100 | 100 | 100 | 100 | 100 | 160 | 160 |
| C | 1000 | 1075 | 1150 | 1225 | 1300 | 1450 | 1600 | 1750 |
| X | 200 | 212 | 225 | 237 | 250 | 275 | 300 | 225 |
| Y | 600 | 325 | 350 | 375 | 400 | 450 | 500 | 550 |
| H | ≤2500 | | | | | | | |
| R | 2 | 3 | 3 | 3 | 3 | 3 | 3 | 5 |
| S | 3 | 3 | 3 | 3 | 3 | 4 | 4 | 4 |
| T | 7 | 8 | 8 | 8 | 8 | 9 | 9 | 11 |

- Puertas homologadas TÜV (DIN 18091).
R: N°. de soportes en mecanismo de rellano.
S: N°. de soportes en apoyo pisadera.
T: N°. de soportes total.
- Doors certified by TÜV (DIN 18091).
R: Number of supports for landing mechanism.
S: Number of supports for sill support.
T: Total number of supports.

Puerta con doble enclavamiento
Door with two locking device

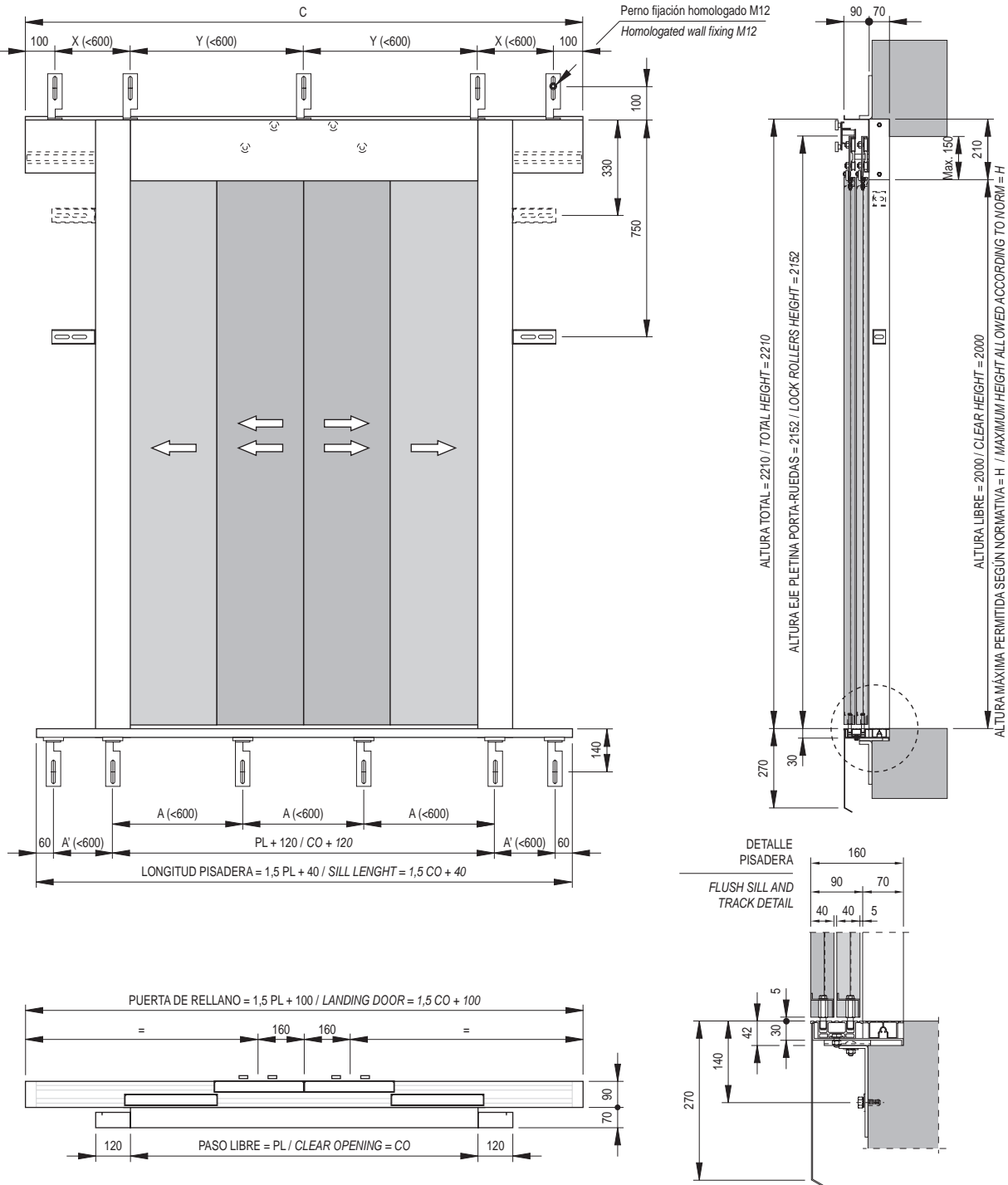

| PL / CO | 1200 | 1300 | 1400 | 1500 | 1600 | 1700 | 1800 | 1900 | 2000 | 2100 | 2200 | 2300 | 2400 | 2500 | 2600 | 2700 | 2800 | 2900 | 3000 |
|---------|-------|------|------|------|------|------|------|------|------|------|------|------|------|------|------|-------|------|-------|------|
| A | 330 | 355 | 380 | 324 | 344 | 364 | 384 | 404 | 353 | 370 | 387 | 403 | 360 | 374 | 340 | 352,5 | 365 | 377,5 | 390 |
| A' | 290 | 255 | 280 | 305 | 330 | 355 | 380 | 405 | 430 | 455 | 480 | 505 | 530 | 555 | 580 | 302 | 315 | 327 | 340 |
| X | 250 | 275 | 300 | 325 | 350 | 375 | 400 | 425 | 450 | 475 | 500 | 525 | 550 | 575 | 600 | 312 | 325 | 337 | 350 |
| Y | 600 | 433 | 467 | 500 | 533 | 567 | 600 | 475 | 500 | 525 | 550 | 575 | 600 | 500 | 520 | 540 | 560 | 580 | 600 |
| H | ≤2500 | | | | | | | | | | | | | | | | | | |
| R | 5 | 7 | 7 | 8 | 8 | 8 | 8 | 8 | 9 | 9 | 9 | 9 | 10 | 10 | 10 | 12 | 12 | 12 | 12 |
| S | 5 | 6 | 6 | 6 | 6 | 6 | 6 | 7 | 7 | 7 | 7 | 7 | 7 | 8 | 8 | 10 | 10 | 10 | 10 |
| T | 12 | 15 | 15 | 16 | 16 | 16 | 16 | 17 | 18 | 18 | 18 | 18 | 19 | 20 | 20 | 24 | 24 | 24 | 24 |

Puertas homologadas TÜV (DIN 18091). R: N°. de soportes en mecanismo de rellano. S: N°. de soportes en apoyo pisadera. T: N°. de soportes total.
 Doors certified by TÜV (DIN 18091). R: Number of supports for landing mechanism. S: Number of supports for sill support. T: Total number of supports.

*: EN POSICIÓN DE PUERTA ABIERTA, EL ENCLAVAMIENTO SOBRESALE 40 mm EN PL 600 Y 15 mm EN PL 700.
*: IN OPEN DOOR POSITION, THE LOCKING DEVICE STICKS OUT 40 mm IN CO 600 AND 15 mm IN CO 700.

Puerta con un enclavamiento
Door with one locking device

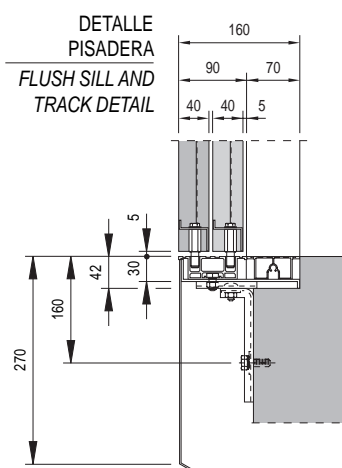
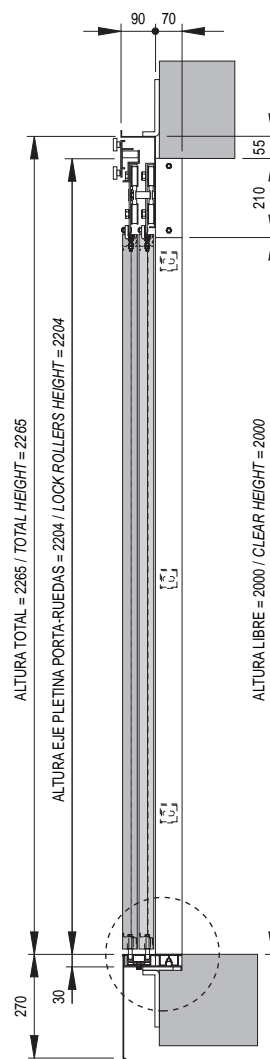
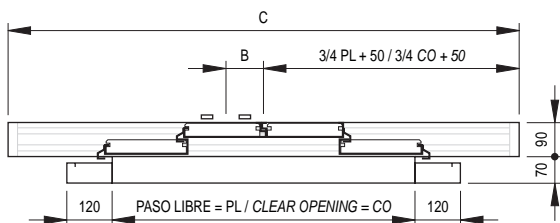
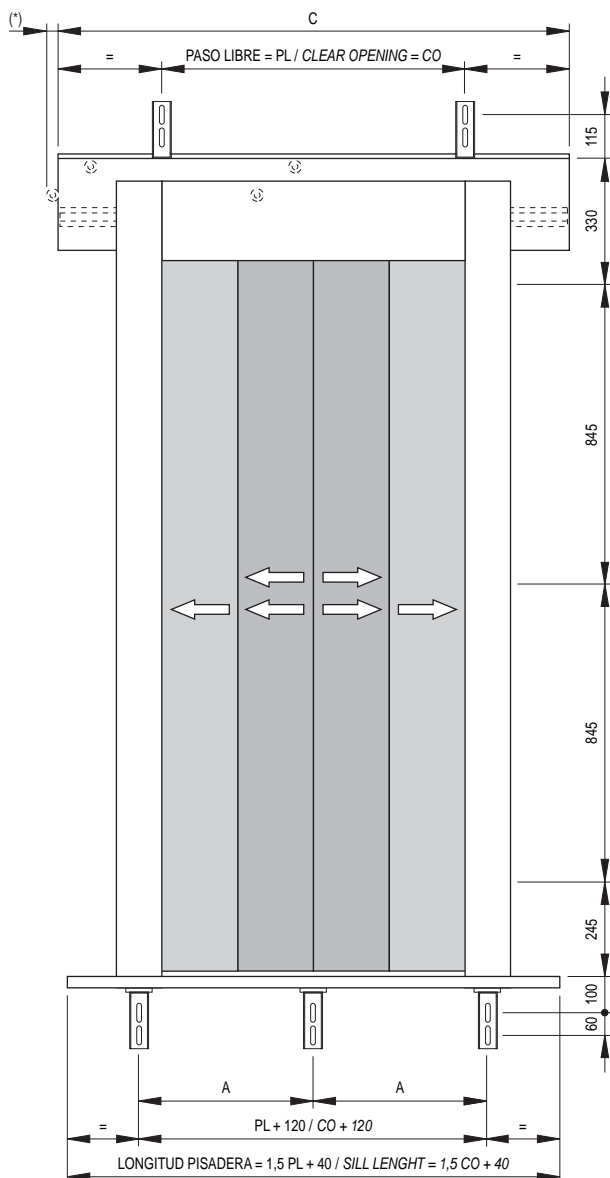

| PL / CO | 600 | 650 | 700 | 750 | 800 | 900 | 1000 | 1100 |
|---------|------|------|------|------|------|------|------|------|
| A | 360 | 385 | 410 | 435 | 460 | 340 | 373 | 407 |
| B | 100 | 100 | 100 | 100 | 100 | 100 | 160 | 160 |
| C | 1050 | 1100 | 1150 | 1225 | 1300 | 1450 | 1600 | 1750 |
| S | 3 | 3 | 3 | 3 | 3 | 4 | 4 | 4 |
| T | 5 | 5 | 5 | 5 | 5 | 6 | 6 | 6 |

S: N° de soportes en apoyo pisadera.
S: Number of supports for sill support.

T: N° de soportes total.
T: Total number of supports.

Puerta con doble enclavamiento
Door with two locking device

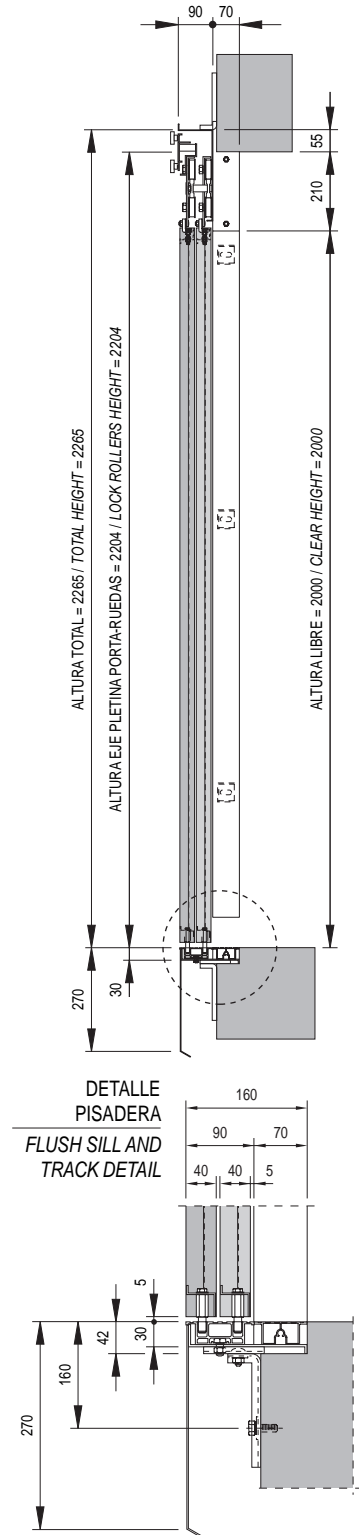
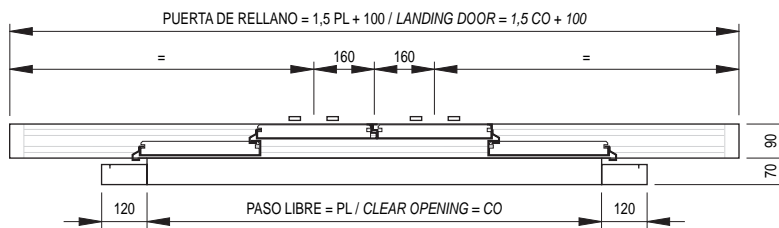
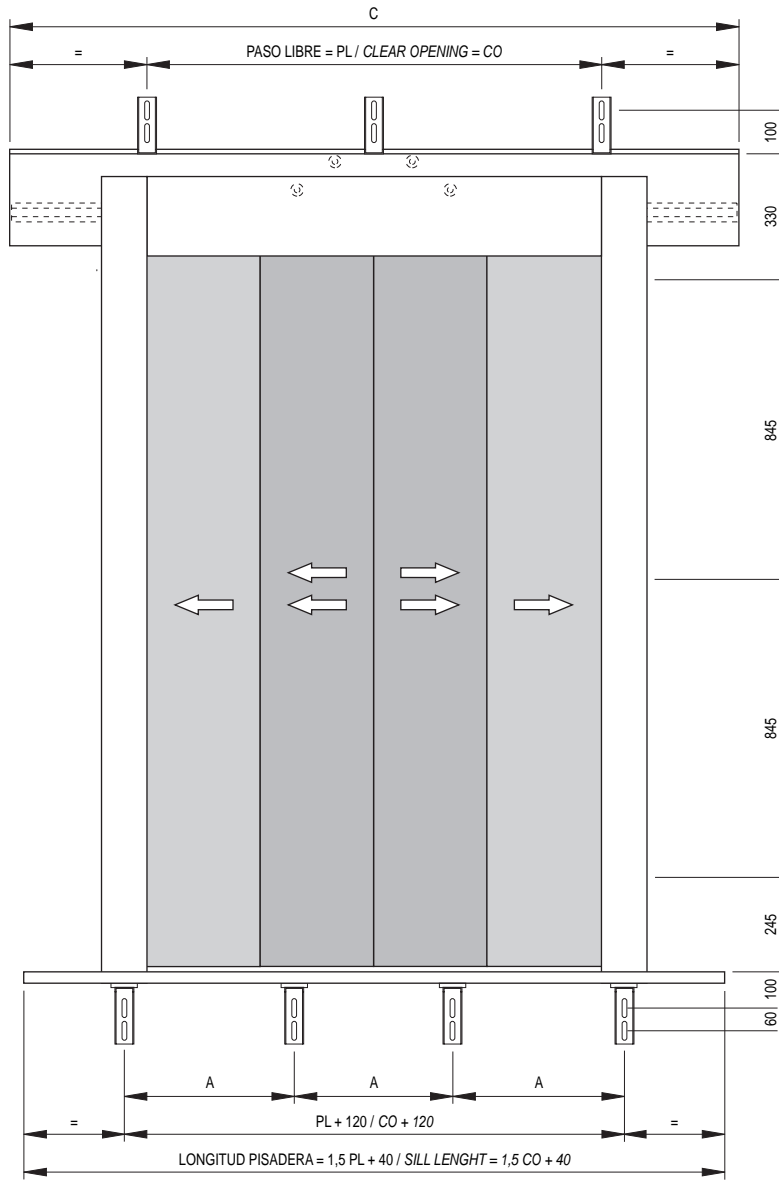

| PL / CO | 1200 | 1300 | 1400 | 1500 | 1600 | 1700 | 1800 | 1900 | 2000 | 2100 | 2200 | 2300 | 2400 | 2500 | 2600 | 2700 | 2800 | 2900 | 3000 |
|---------|------|------|------|------|------|------|------|------|------|------|------|------|------|------|------|-------|------|-------|------|
| A | 330 | 355 | 380 | 324 | 344 | 364 | 384 | 404 | 353 | 370 | 387 | 403 | 360 | 374 | 340 | 352,5 | 365 | 377,5 | 390 |
| C | 1900 | 2050 | 2200 | 2350 | 2500 | 2650 | 2800 | 2950 | 3100 | 3250 | 3400 | 3550 | 3700 | 3850 | 4000 | 4150 | 4300 | 4450 | 4600 |
| S | 5 | 5 | 5 | 6 | 6 | 6 | 6 | 6 | 7 | 7 | 7 | 7 | 8 | 8 | 9 | 9 | 9 | 9 | 9 |
| T | 8 | 8 | 9 | 9 | 9 | 10 | 11 | 11 | 12 | 12 | 12 | 13 | 14 | 14 | 15 | 15 | 15 | 16 | 17 |

S: N°. de soportes en apoyo pisadera.
S: Number of supports for sill support.

T: N°. de soportes total.
T: Total number of supports.

Puerta con un enclavamiento
Door with one locking device

*: EN POSICIÓN DE PUERTA ABIERTA, EL ENCLAVAMIENTO SOBRESALE 40 mm EN PL 600 Y 15 mm EN PL 700.
*: IN OPEN DOOR POSITION, THE LOCKING DEVICE STICKS OUT 40 mm IN CO 600 AND 15 mm IN CO 700.

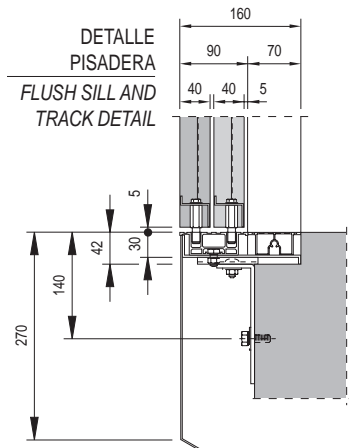
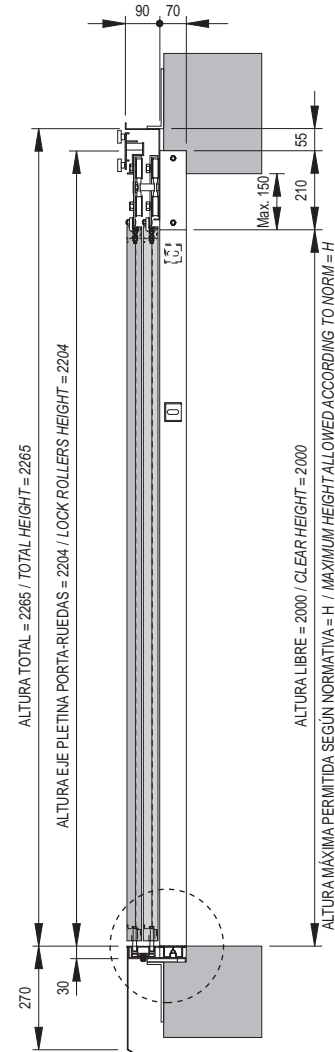
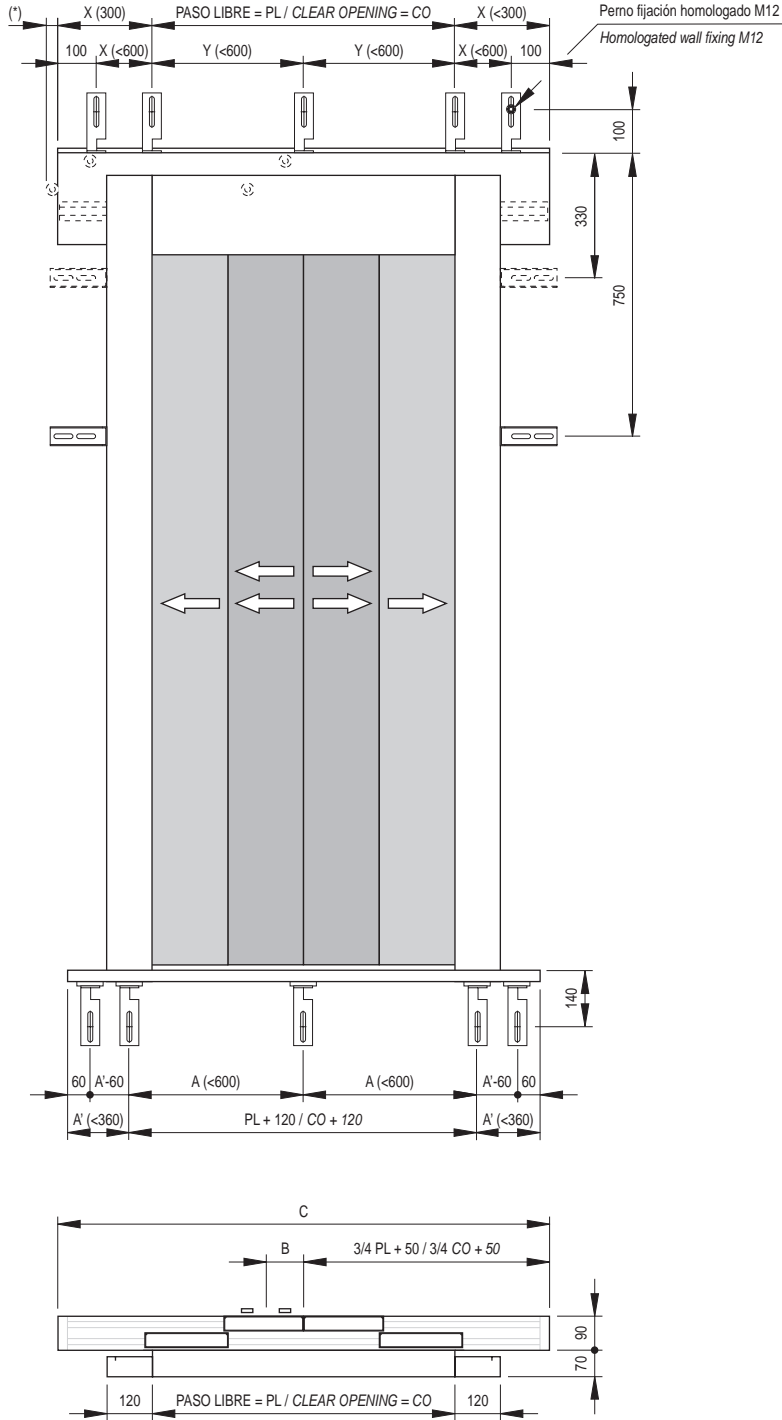

| PL / CO | 600 | 650 | 700 | 750 | 800 | 900 | 1000 | 1100 |
|---------|-------|------|------|------|------|------|------|------|
| A | 360 | 385 | 410 | 435 | 460 | 340 | 373 | 407 |
| A' | 140 | 152 | 165 | 177 | 190 | 215 | 240 | 265 |
| B | 100 | 100 | 100 | 100 | 100 | 100 | 160 | 160 |
| C | 1050 | 1100 | 1150 | 1225 | 1300 | 1450 | 1600 | 1750 |
| X | 200 | 212 | 225 | 237 | 250 | 275 | 300 | 225 |
| Y | 600 | 325 | 350 | 375 | 400 | 450 | 500 | 550 |
| H | ≤2500 | | | | | | | |
| R | 2 | 3 | 3 | 3 | 3 | 3 | 3 | 5 |
| S | 3 | 3 | 3 | 3 | 3 | 4 | 4 | 4 |
| T | 7 | 8 | 8 | 8 | 8 | 9 | 9 | 11 |

- Puertas homologadas TÜV (DIN 18091).
R: N° de soportes en mecanismo de rellano.
S: N° de soportes en apoyo pisadera.
T: N° de soportes total.
- Doors certified by TÜV (DIN 18091).
R: Number of supports for landing mechanism.
S: Number of supports for sill support.
T: Total number of supports.

2.12.

PUERTA RELLANO CENTRAL 4 HOJAS 4 PANEL CENTRE PARTING LANDING DOOR

50/11
DIN 18.091

Fermator
AUTOMATIC DOORS FOR LIFTS

2

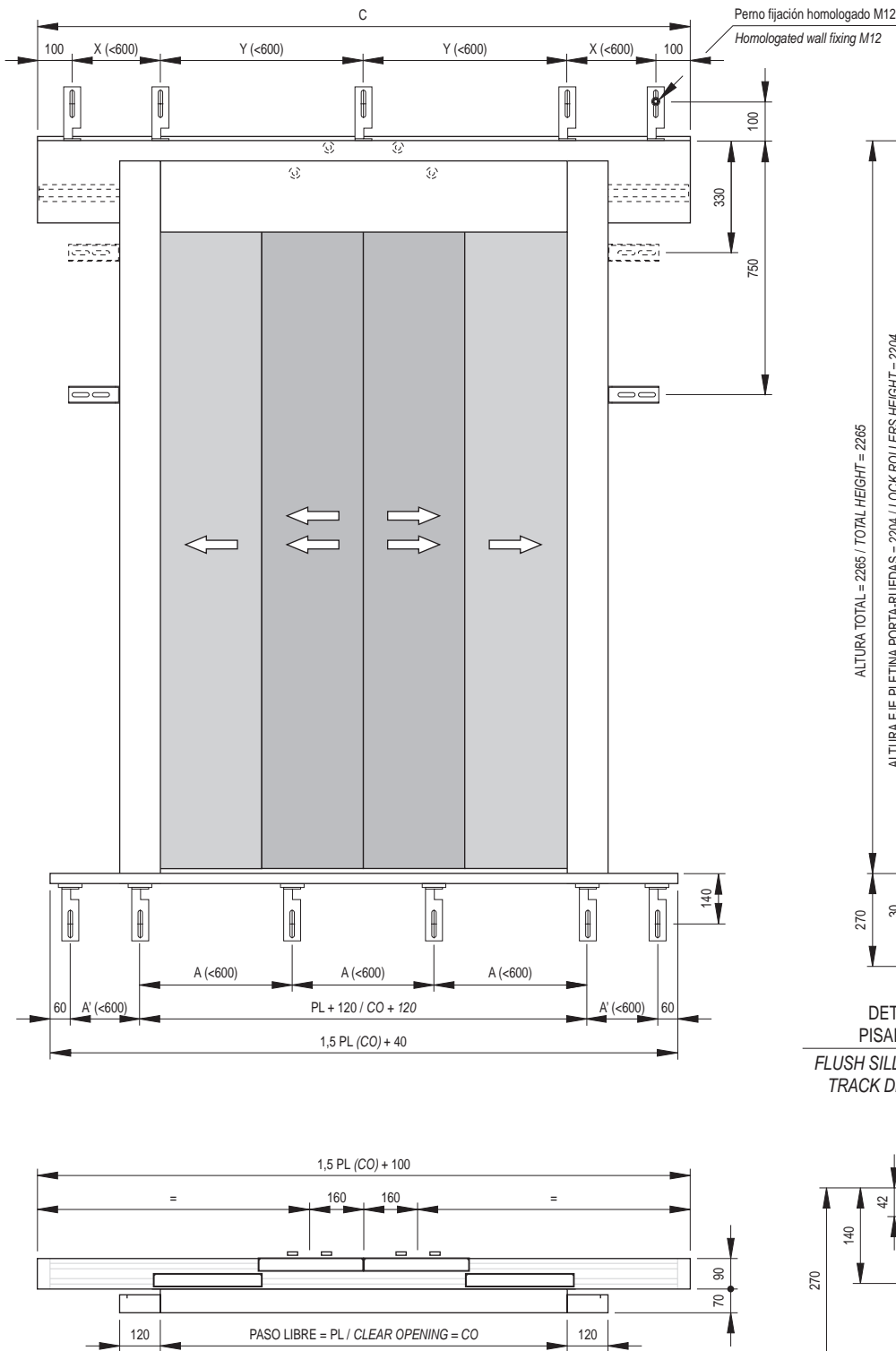

Puerta con doble enclavamiento
Door with two locking devices

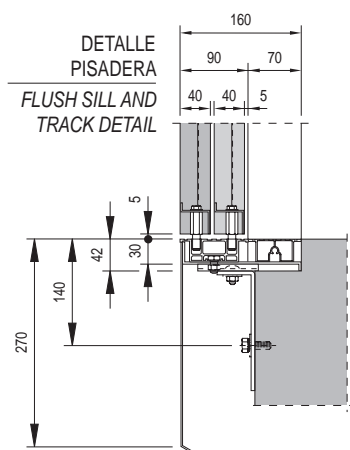
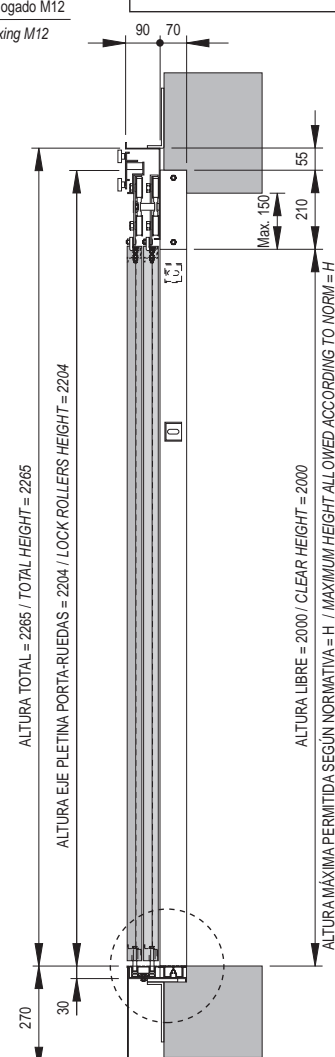

| PL / CO | 1200 | 1300 | 1400 | 1500 | 1600 | 1700 | 1800 | 1900 | 2000 | 2100 | 2200 | 2300 | 2400 | 2500 | 2600 | 2700 | 2800 | 2900 | 3000 | |
|---------|-------|-----------|------|------|------|------|------|------|------|------|------|------|------|------|------|-------|------|-------|------|--|
| A | 330 | 335 | 380 | 324 | 344 | 364 | 384 | 404 | 353 | 370 | 387 | 403 | 360 | 374 | 340 | 352,5 | 365 | 377,5 | 390 | |
| A' | 290 | 255 | 280 | 305 | 330 | 355 | 380 | 405 | 430 | 455 | 480 | 505 | 530 | 555 | 580 | 302 | 315 | 327 | 340 | |
| X | 250 | 275 | 300 | 325 | 350 | 375 | 400 | 425 | 450 | 475 | 500 | 525 | 550 | 575 | 600 | 312 | 325 | 337 | 350 | |
| Y | 600 | 433 | 467 | 500 | 533 | 567 | 600 | 475 | 500 | 525 | 550 | 575 | 600 | 500 | 520 | 540 | 560 | 580 | 600 | |
| H | ≤2900 | 2000-3000 | | | | | | | | | | | | | | | | | | |
| R | 5 | 7 | 7 | 8 | 8 | 8 | 8 | 8 | 9 | 9 | 9 | 9 | 10 | 10 | 10 | 12 | 12 | 12 | 12 | |
| S | 5 | 6 | 6 | 6 | 6 | 6 | 6 | 7 | 7 | 7 | 7 | 7 | 7 | 8 | 8 | 10 | 10 | 10 | 10 | |
| T | 12 | 15 | 15 | 16 | 16 | 16 | 16 | 17 | 18 | 18 | 18 | 18 | 19 | 20 | 20 | 24 | 24 | 24 | 24 | |

Puertas homologadas TÜV (DIN 18091). R: N° de soportes en mecanismo de rellano. S: N° de soportes en apoyo pisadera. T: N° de soportes total.
 Doors certified by TÜV (DIN 18091). R: Number of supports for landing mechanism. S: Number of supports for sill support. T: Total number of supports.

Puerta rellano central 4 hojas modelo 40/10
4 panel centre parting landing door model 40/10

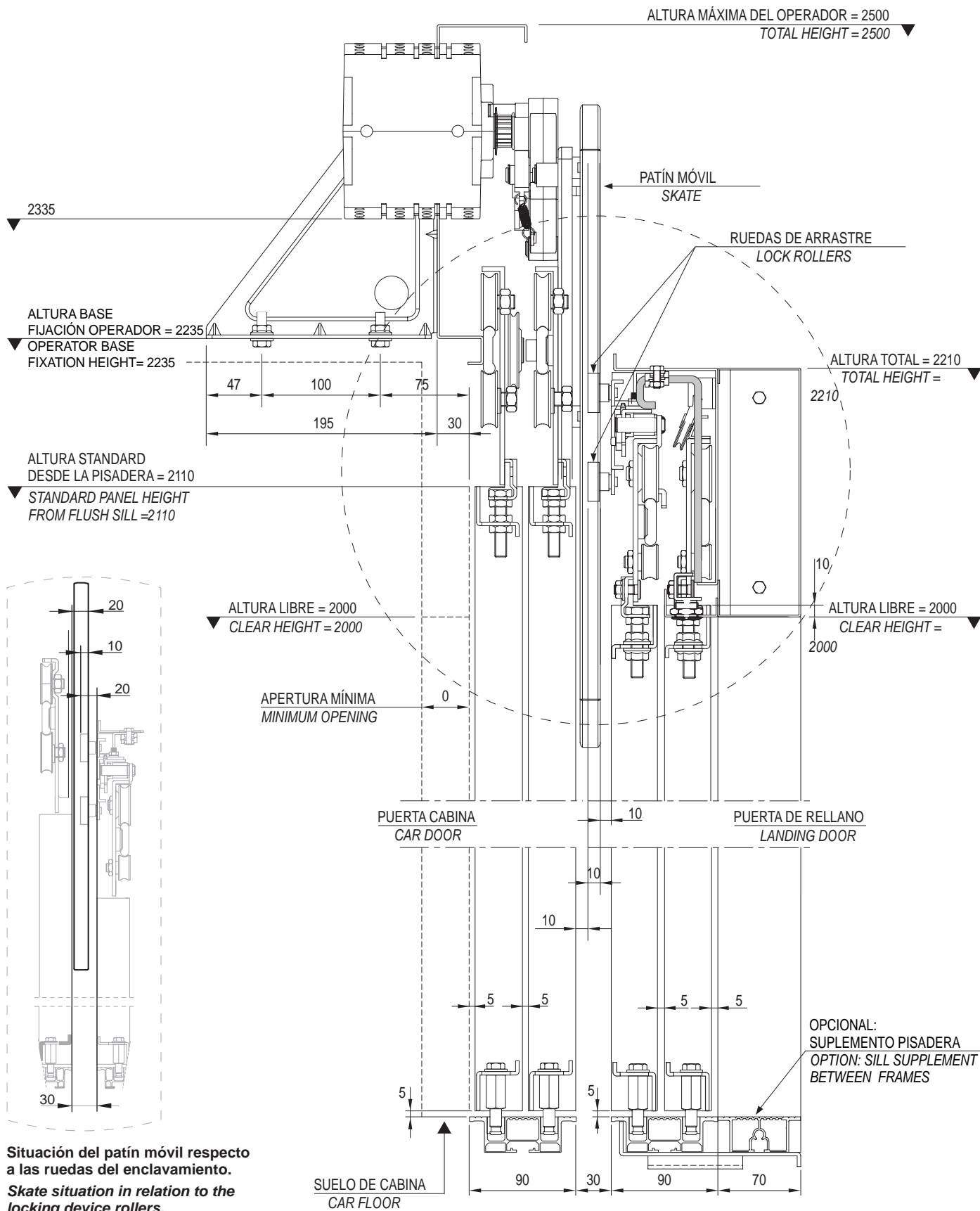

Situación del patín móvil respecto a las ruedas del enclavamiento.
Skate situation in relation to the locking device rollers.

2.14.

SITUACIÓN DEL PATÍN CON LAS RUEDAS DE ARRASTRE COUPLING ARRANGEMENT BETWEEN SKATE AND LOCK

Fermator
AUTOMATIC DOORS FOR LIFTS

Puerta rellano central 4 hojas modelo 50/11
4 panel centre parting landing door model 50/11

2

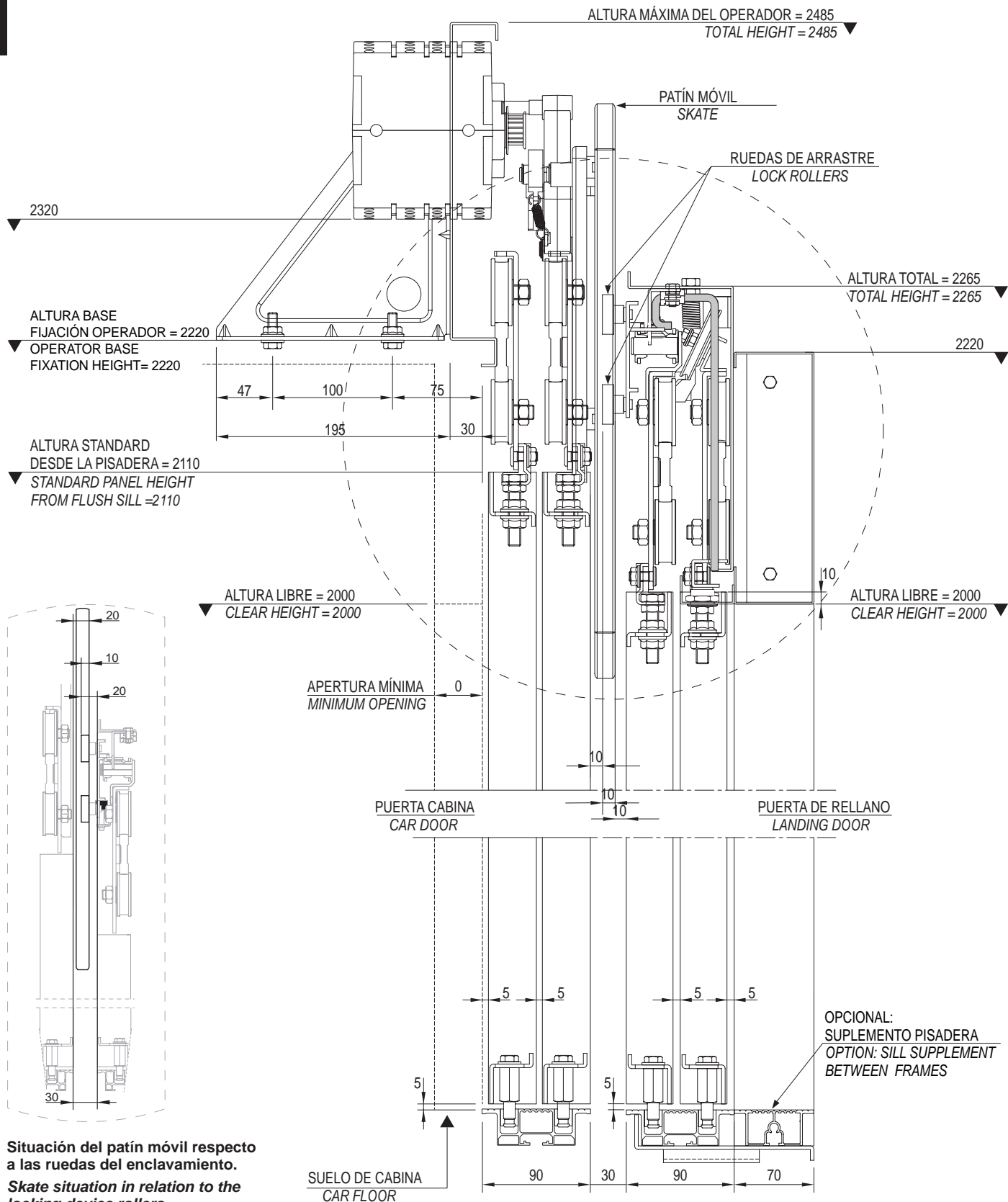

Ferrotec

AUTOMATIC DOORS FOR LIFTS

PUERTA CENTRAL DE 6 HOJAS
6 PANEL CENTRE PARTING DOOR

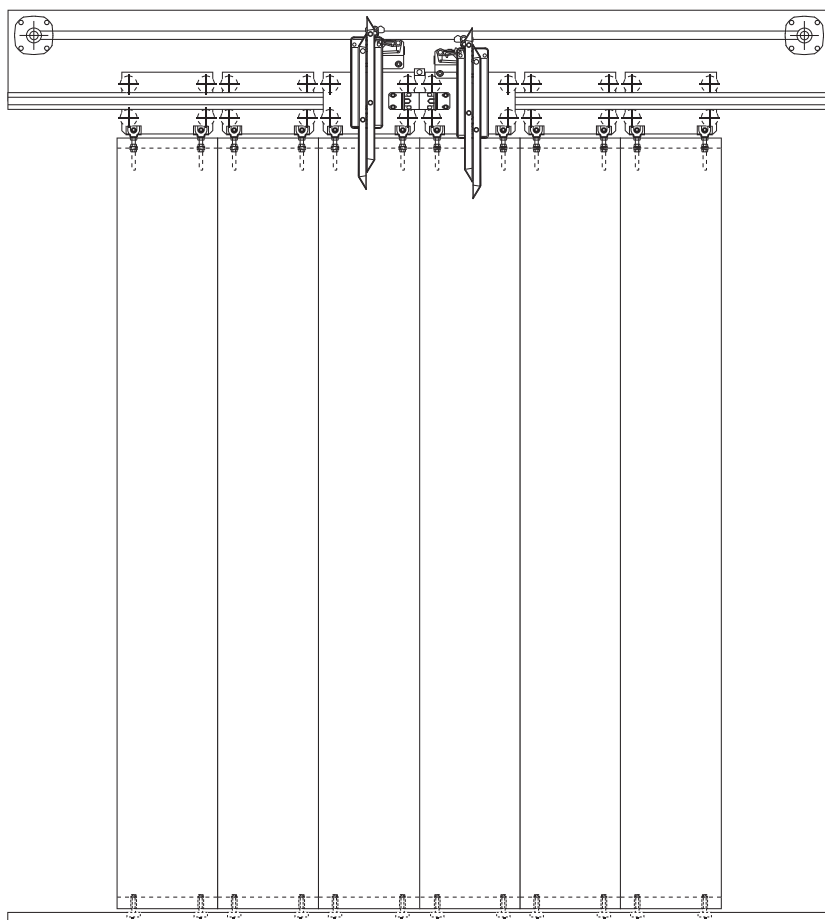

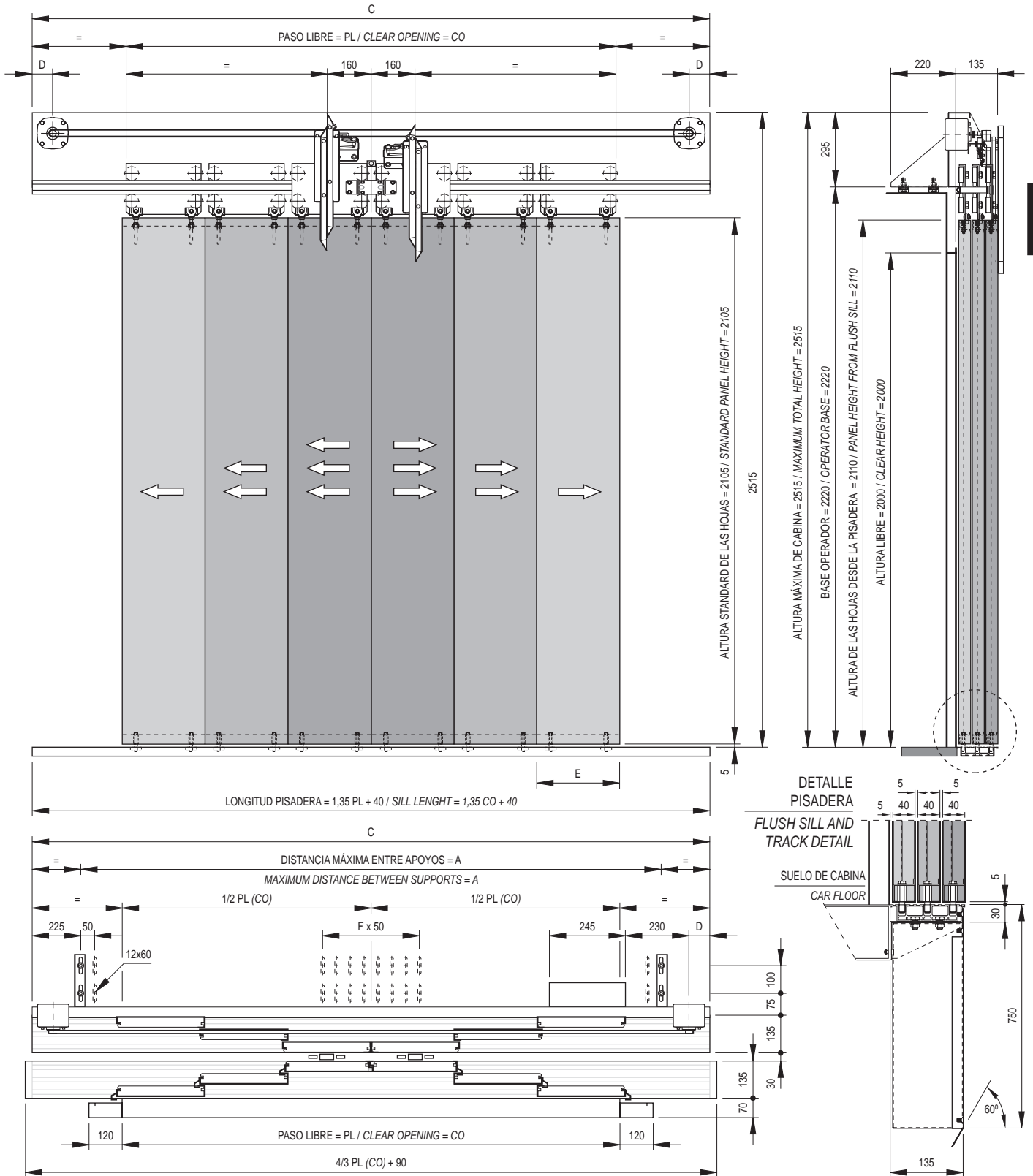

3

Dos Motores / Two Motors

| PL / CO | 1200 | 1300 | 1400 | 1500 | 1600 | 1700 | 1800 | 1900 | 2000 | 2100 | 2200 | 2300 | 2400 | 2500 | 2600 | 2700 | 2800 | 2900 | 3000 |
|--------------------|-------|-------|-------|-------|------|------|------|------|-------|------|------|-------|------|------|------|------|-------|-------|-------|
| A | 1200 | 1350 | 1500 | 1600 | 1750 | 1900 | 2000 | 2150 | 2300 | 2400 | 2550 | 2700 | 2800 | 2950 | 3100 | 3200 | 3350 | 3500 | 3600 |
| C | 1650 | 1800 | 1950 | 2050 | 2200 | 2350 | 2450 | 2600 | 2750 | 2850 | 3000 | 3150 | 3250 | 3400 | 3550 | 3650 | 3800 | 3950 | 4050 |
| D | 75 | 75 | 75 | 75 | 75 | 75 | 75 | 75 | 125 | 125 | 125 | 175 | 175 | 175 | 225 | 225 | 225 | 275 | 275 |
| E | 220 | 235 | 253 | 270 | 285 | 305 | 320 | 335 | 353 | 370 | 385 | 405 | 420 | 435 | 453 | 470 | 485 | 505 | 520 |
| F | 6 | 6 | 8 | 8 | 10 | 10 | 12 | 12 | 14 | 14 | 16 | 16 | 18 | 18 | 18 | 20 | 20 | 20 | 20 |
| TIEMPO / TIME (s) | 1,73 | 1,8 | 1,87 | 1,94 | 2 | 2,06 | 2,12 | 2,18 | 2,24 | 2,29 | 2,35 | 2,4 | 2,45 | 2,5 | 2,55 | 2,6 | 2,65 | 2,7 | 2,75 |
| PESO / WEIGHT (kg) | 142,5 | 154,5 | 166,5 | 178,5 | 190 | 202 | 214 | 226 | 237,5 | 250 | 262 | 273,5 | 285 | 297 | 309 | 321 | 332,5 | 344,5 | 356,5 |

3.2.

PUERTA RELLANO CENTRAL 6 HOJAS 6 PANEL CENTRE PARTING LANDING DOOR

40/10

Fermator
AUTOMATIC DOORS FOR LIFTS

3

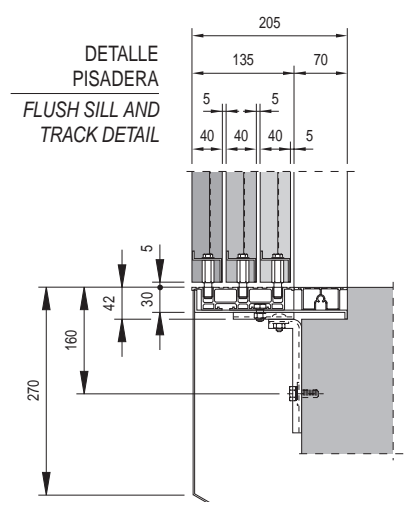
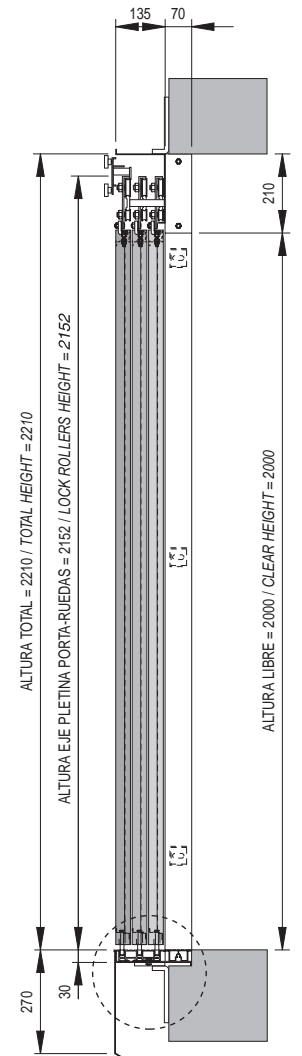
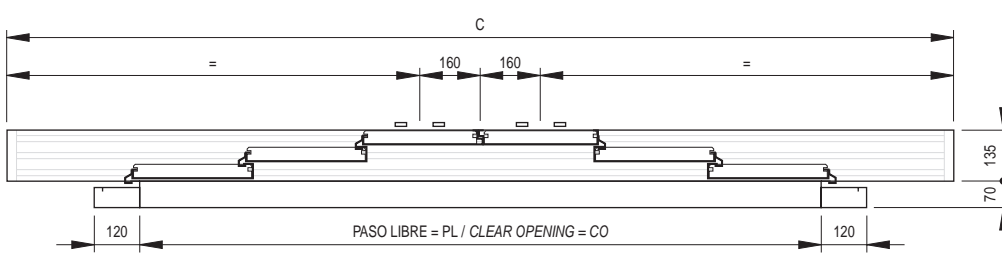
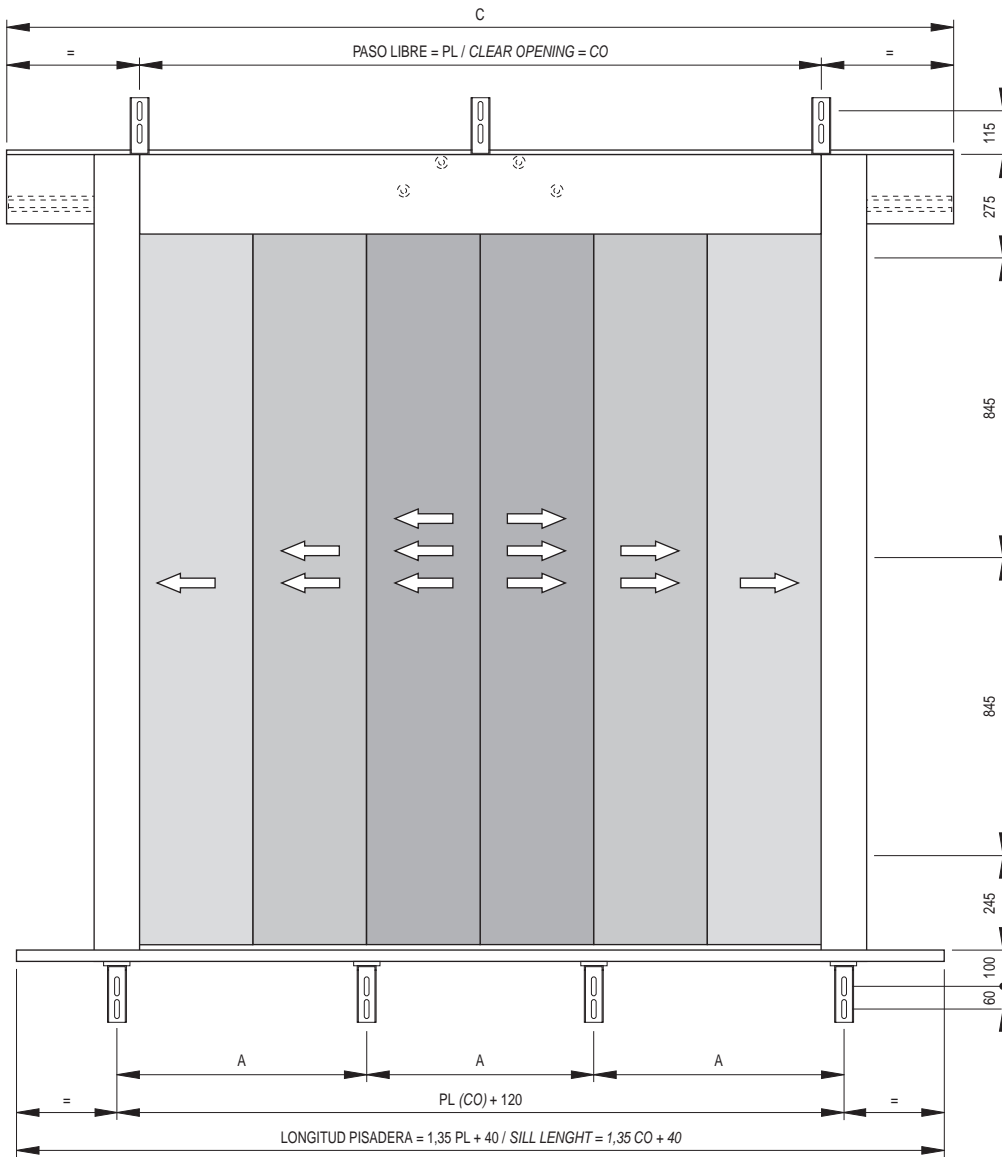

| PL / CO | 1200 | 1300 | 1400 | 1500 | 1600 | 1700 | 1800 | 1900 | 2000 | 2100 | 2200 | 2300 | 2400 | 2500 | 2600 |
|---------|------|------|------|------|------|------|------|------|------|------|------|------|------|------|------|
| A | 330 | 355 | 380 | 324 | 344 | 364 | 384 | 404 | 353 | 370 | 387 | 403 | 360 | 374 | 340 |
| C | 1690 | 1824 | 1957 | 2090 | 2224 | 2357 | 2490 | 2624 | 2757 | 2890 | 3024 | 3157 | 3290 | 3424 | 3557 |
| S | 5 | 5 | 5 | 6 | 6 | 7 | 7 | 7 | 8 | 8 | 8 | 9 | 9 | 9 | 10 |
| T | 8 | 8 | 8 | 9 | 9 | 10 | 11 | 11 | 12 | 12 | 12 | 13 | 14 | 14 | 15 |

S: N° de soportes en apoyo pisadera.
S: Number of supports for sill support.

T: N° de soportes total.
T: Total number of supports.

Puerta con frontis
Door with infill panels

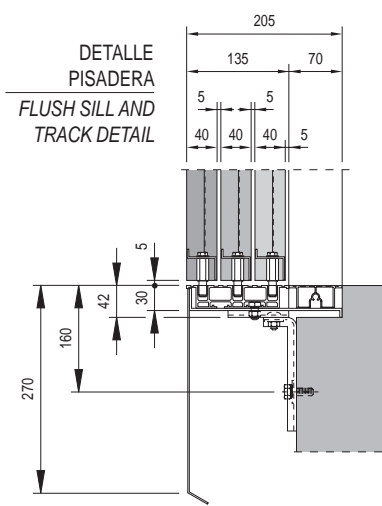
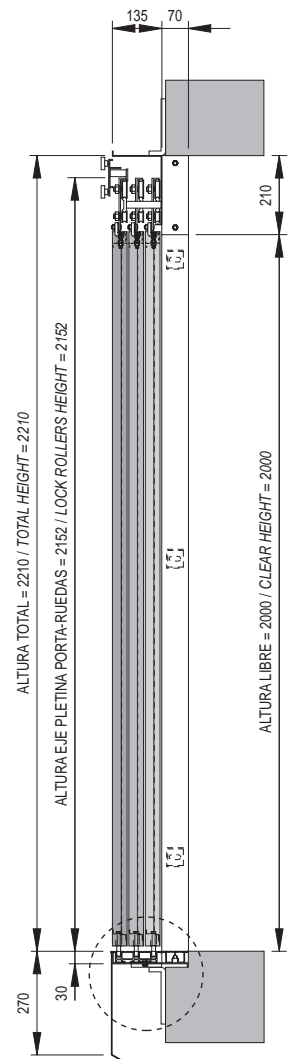
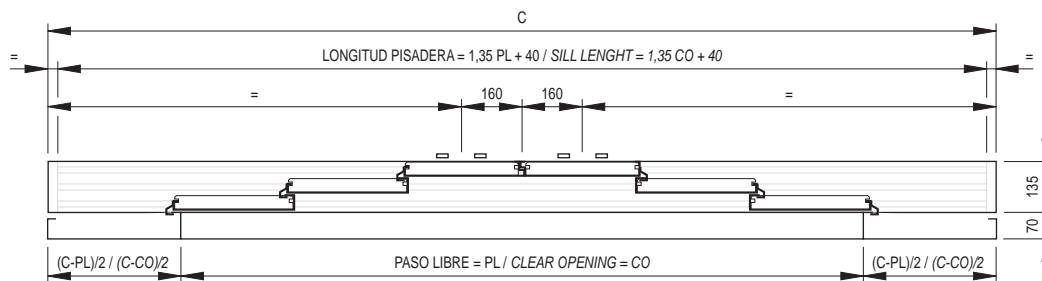
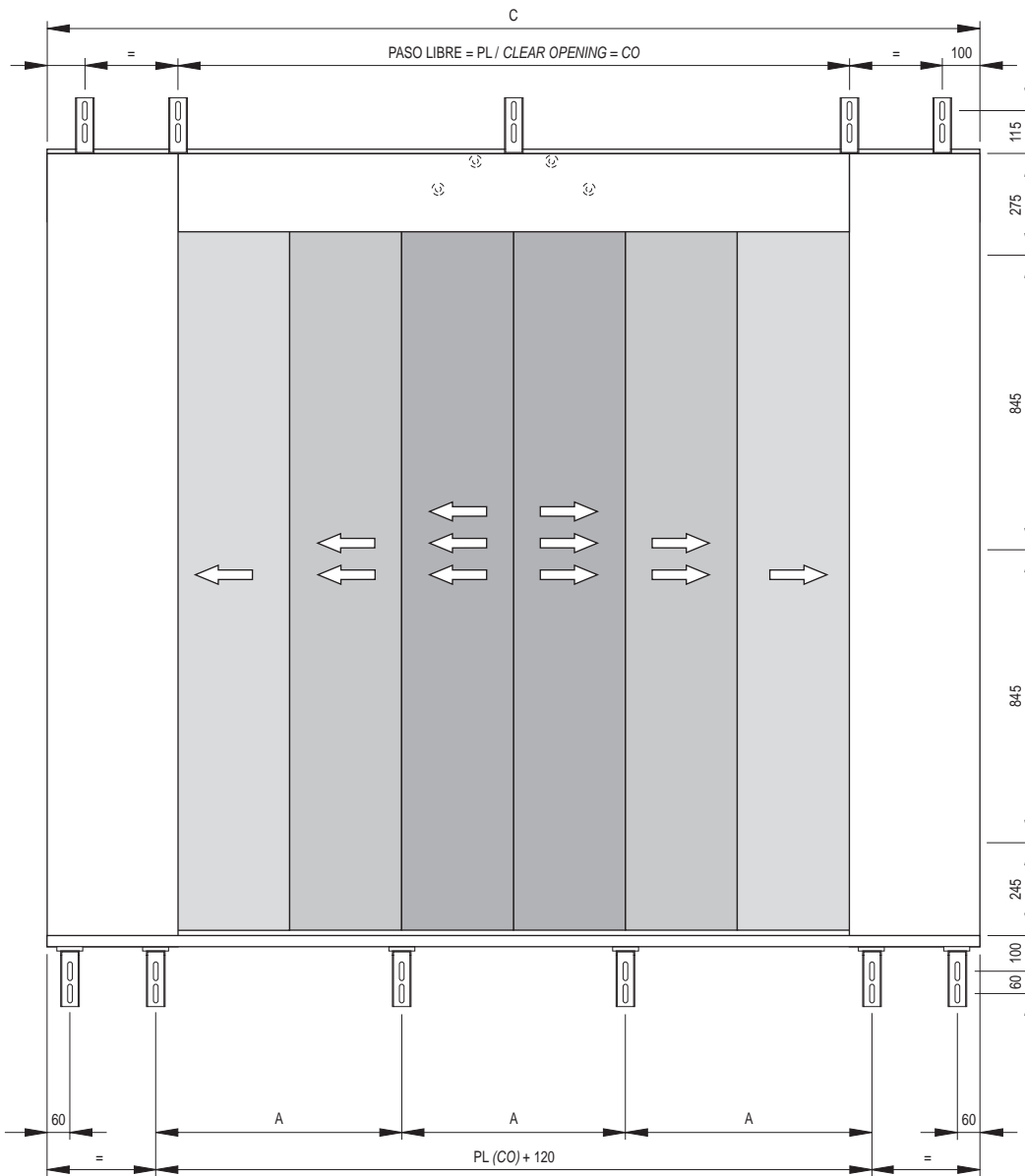

| PL / CO | 1200 | 1300 | 1400 | 1500 | 1600 | 1700 | 1800 | 1900 | 2000 | 2100 | 2200 | 2300 | 2400 | 2500 | 2600 |
|---------|------|------|------|------|------|------|------|------|------|------|------|------|------|------|------|
| A | 330 | 355 | 380 | 324 | 344 | 364 | 384 | 404 | 353 | 370 | 387 | 403 | 360 | 374 | 340 |
| C | 1690 | 1824 | 1957 | 2090 | 2224 | 2357 | 2490 | 2624 | 2757 | 2890 | 3024 | 3157 | 3290 | 3424 | 3557 |
| S | 5 | 5 | 5 | 6 | 6 | 7 | 7 | 7 | 8 | 8 | 8 | 9 | 9 | 9 | 10 |
| T | 10 | 10 | 10 | 11 | 11 | 12 | 13 | 13 | 14 | 14 | 14 | 15 | 16 | 16 | 17 |

S: N°. de soportes en apoyo pisadera.
S: Number of supports for sill support.

T: N°. de soportes total.
T: Total number of supports.

3.4.

PUERTA RELLANO CENTRAL 6 HOJAS 6 PANEL CENTRE PARTING LANDING DOOR

40/10
DIN 18.091

Fermator
AUTOMATIC DOORS FOR LIFTS

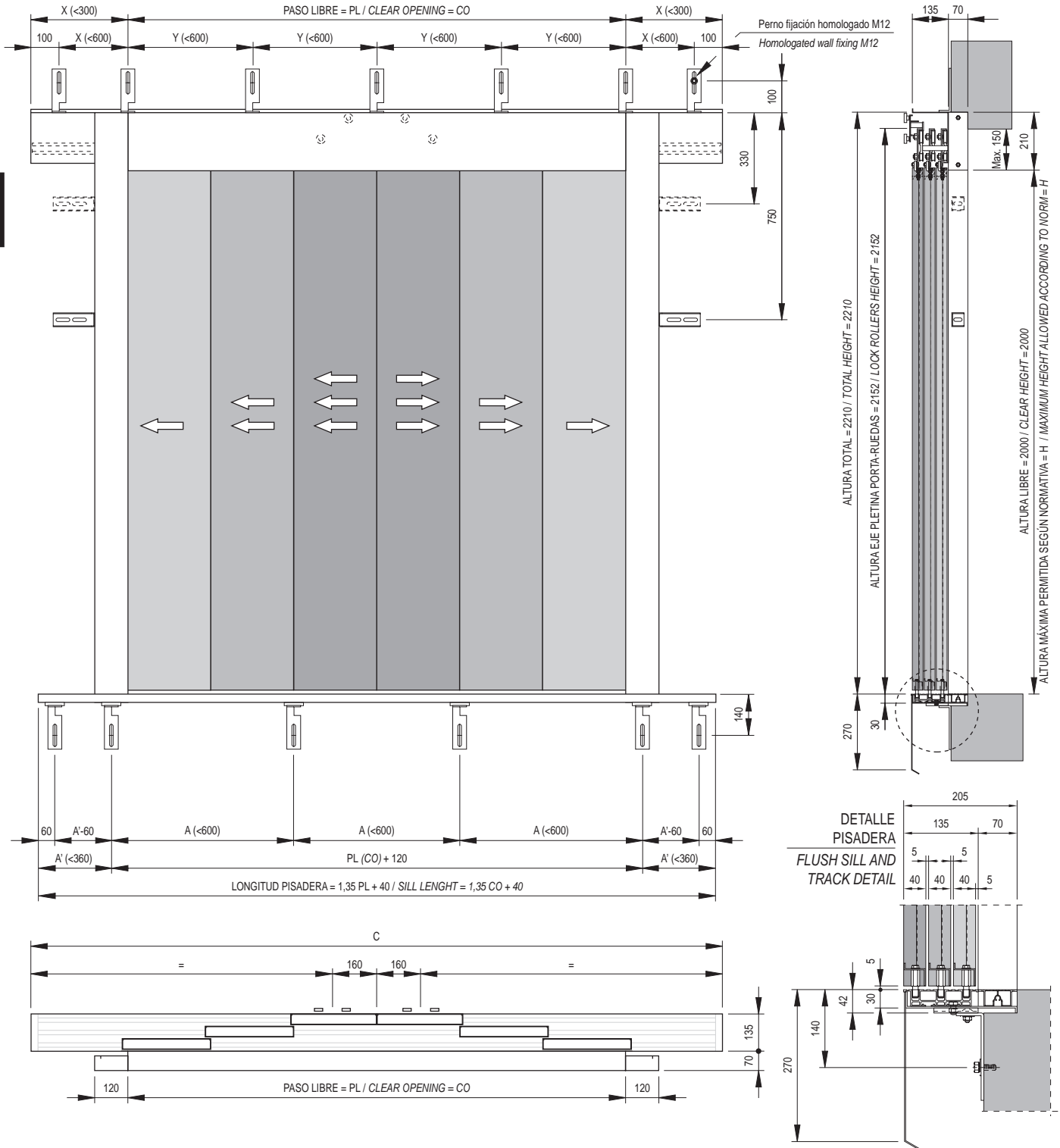

| PL / CO | 1200 | 1300 | 1400 | 1500 | 1600 | 1700 | 1800 | 1900 | 2000 | 2100 | 2200 | 2300 | 2400 | 2500 | 2600 | 2700 | 2800 |
|---------|-------|------|------|------|------|------|------|------|------|------|------|------|------|------|------|------|------|
| A | 330 | 355 | 380 | 324 | 344 | 364 | 384 | 404 | 353 | 370 | 387 | 403 | 360 | 374 | 340 | 353 | 365 |
| A' | 185 | 202 | 218 | 235 | 252 | 268 | 285 | 242 | 258 | 275 | 302 | 308 | 325 | 342 | 358 | 375 | 392 |
| C | 1690 | 1824 | 1957 | 2090 | 2224 | 2357 | 2490 | 2624 | 2757 | 2890 | 3024 | 3157 | 3290 | 3424 | 3557 | 3690 | 3824 |
| X | 245 | 262 | 278 | 295 | 262 | 278 | 295 | 312 | 328 | 345 | 362 | 378 | 395 | 412 | 428 | 395 | 412 |
| Y | 600 | 433 | 467 | 500 | 533 | 567 | 600 | 475 | 500 | 525 | 550 | 575 | 600 | 500 | 520 | 540 | 560 |
| H | ≤2500 | | | | | | | | | | | | | | | | |
| R | 3 | 4 | 4 | 4 | 6 | 6 | 6 | 7 | 7 | 7 | 7 | 7 | 7 | 8 | 8 | 8 | 8 |
| S | 5 | 5 | 5 | 6 | 6 | 6 | 6 | 8 | 9 | 9 | 9 | 9 | 10 | 10 | 11 | 11 | 11 |
| T | 10 | 11 | 11 | 12 | 14 | 14 | 14 | 17 | 18 | 18 | 18 | 18 | 19 | 20 | 21 | 21 | 21 |

Puertas homologadas TÜV (DIN 18091). R: N°. de soportes en mecanismo de rellano. S: N°. de soportes en apoyo pisadera. T: N°. de soportes total.
 Doors certified by TÜV (DIN 18091). R: Number of supports for landing mechanism. S: Number of supports for sill support. T: Total number of supports.

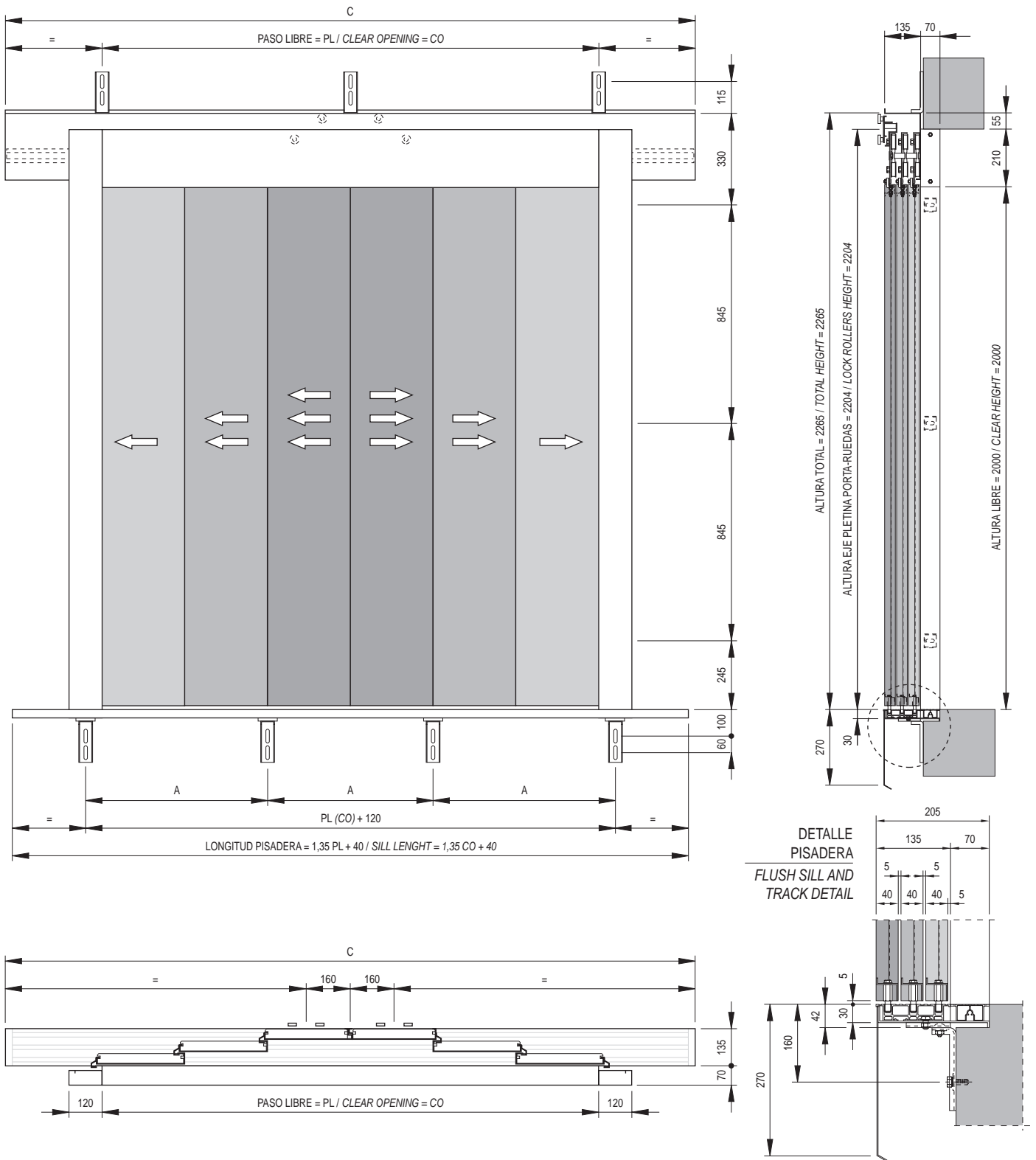

3

| PL / CO | 1200 | 1300 | 1400 | 1500 | 1600 | 1700 | 1800 | 1900 | 2000 | 2100 | 2200 | 2300 | 2400 | 2500 | 2600 | 2700 | 2800 | 2900 | 3000 |
|---------|------|------|------|------|------|------|------|------|------|------|------|------|------|------|------|------|------|------|------|
| A | 330 | 355 | 380 | 324 | 344 | 364 | 384 | 404 | 353 | 370 | 387 | 403 | 360 | 374 | 340 | 352 | 365 | 377 | 347 |
| C | 1690 | 1824 | 1957 | 2090 | 2224 | 2357 | 2490 | 2624 | 2757 | 2890 | 3024 | 3157 | 3290 | 3424 | 3557 | 3690 | 3824 | 3960 | 4094 |
| S | 5 | 5 | 5 | 6 | 6 | 7 | 7 | 7 | 8 | 8 | 8 | 9 | 9 | 9 | 10 | 10 | 10 | 10 | 10 |
| T | 8 | 8 | 8 | 9 | 9 | 10 | 11 | 11 | 12 | 12 | 12 | 13 | 14 | 14 | 15 | 15 | 15 | 15 | 16 |

S: N° de soportes en apoyo pisadera.
S: Number of supports for sill support.

T: N° de soportes total.
T: Total number of supports.

3.6.

PUERTA RELLANO CENTRAL 6 HOJAS 6 PANEL CENTRE PARTING LANDING DOOR

50/11
DIN 18.091

Fermator
AUTOMATIC DOORS FOR LIFTS

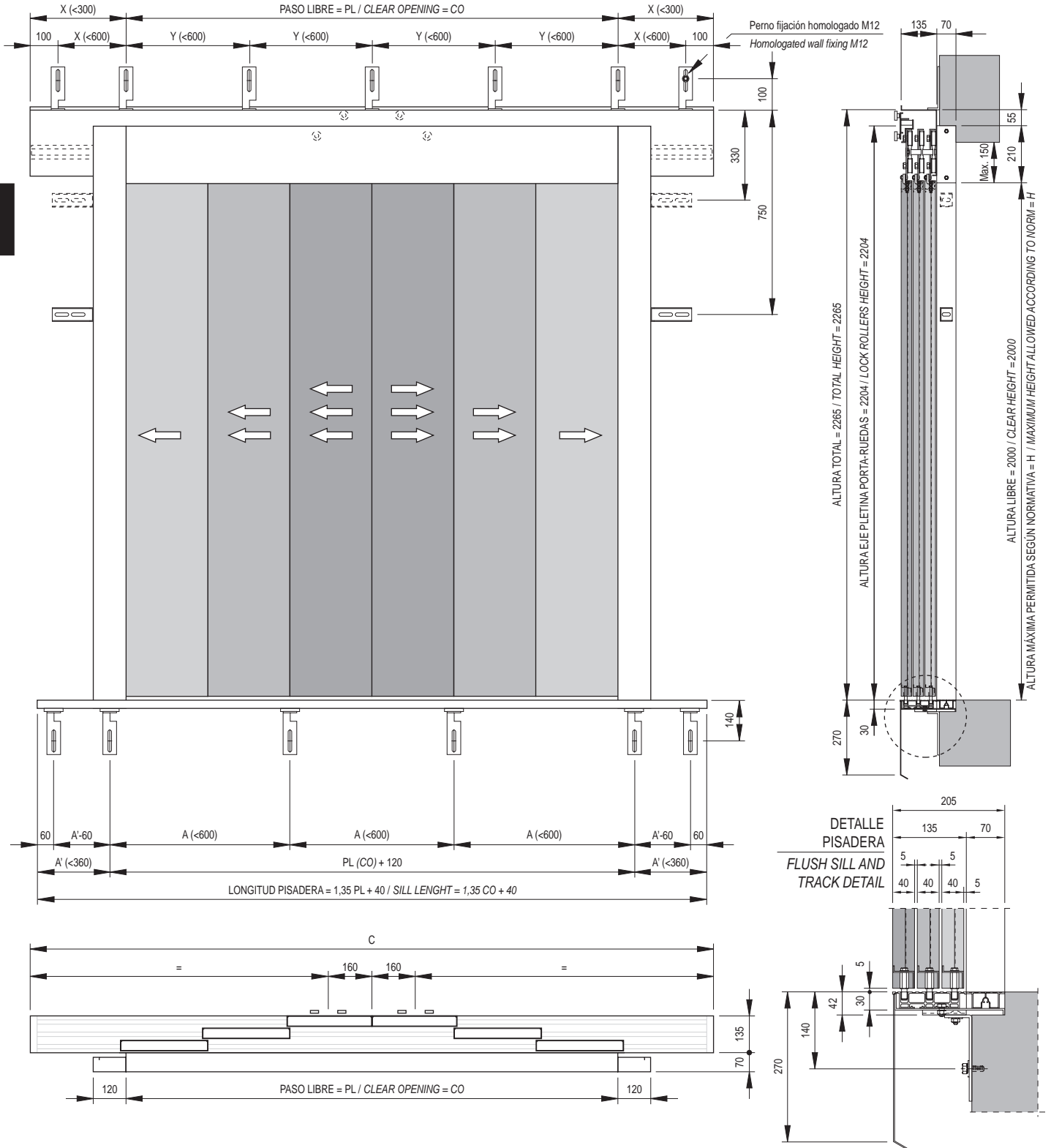

| PL / CO | 1200 | 1300 | 1400 | 1500 | 1600 | 1700 | 1800 | 1900 | 2000 | 2100 | 2200 | 2300 | 2400 | 2500 | 2600 | 2700 | 2800 | 2900 | 3000 | |
|---------|-------|------|------|------|------|------|------|------|------|------|------|------|------|------|------|------|------|------|------|--|
| A | 330 | 355 | 380 | 324 | 344 | 364 | 384 | 404 | 353 | 370 | 387 | 403 | 360 | 374 | 340 | 352 | 365 | 377 | 390 | |
| A' | 185 | 202 | 218 | 235 | 252 | 268 | 285 | 242 | 258 | 275 | 302 | 308 | 325 | 342 | 358 | 375 | 392 | 410 | 427 | |
| C | 1690 | 1824 | 1957 | 2090 | 2224 | 2357 | 2490 | 2624 | 2757 | 2890 | 3024 | 3157 | 3290 | 3424 | 3557 | 3690 | 3824 | 3960 | 4094 | |
| X | 245 | 262 | 278 | 295 | 262 | 278 | 295 | 312 | 328 | 345 | 362 | 378 | 395 | 412 | 428 | 445 | 462 | 480 | 497 | |
| Y | 600 | 433 | 467 | 500 | 533 | 567 | 600 | 475 | 500 | 525 | 550 | 575 | 600 | 500 | 520 | 540 | 560 | 580 | 600 | |
| H | ≤2500 | | | | | | | | | | | | | | | | | | | |
| R | 3 | 4 | 4 | 4 | 6 | 6 | 6 | 7 | 7 | 7 | 7 | 7 | 7 | 8 | 8 | 8 | 8 | 8 | 8 | |
| S | 5 | 5 | 5 | 6 | 6 | 6 | 6 | 8 | 9 | 9 | 9 | 9 | 10 | 10 | 11 | 11 | 11 | 11 | 11 | |
| T | 10 | 11 | 11 | 12 | 14 | 14 | 14 | 17 | 18 | 18 | 18 | 18 | 19 | 20 | 21 | 21 | 21 | 21 | 21 | |

□ Puertas homologadas TÜV (DIN 18091). R: N°. de soportes en mecanismo de rellano.
 □ Doors certified by TÜV (DIN 18091). R: Number of supports for landing mechanism.

S: N°. de soportes en apoyo pisadera.
 S: Number of supports for sill support.

T: N°. de soportes total.
 T: Total number of supports.

Puerta rellano central 6 hojas modelo 40/10 (pisadera 135mm)
6 panel centre parting landing door model 40/10 (sill 135mm)

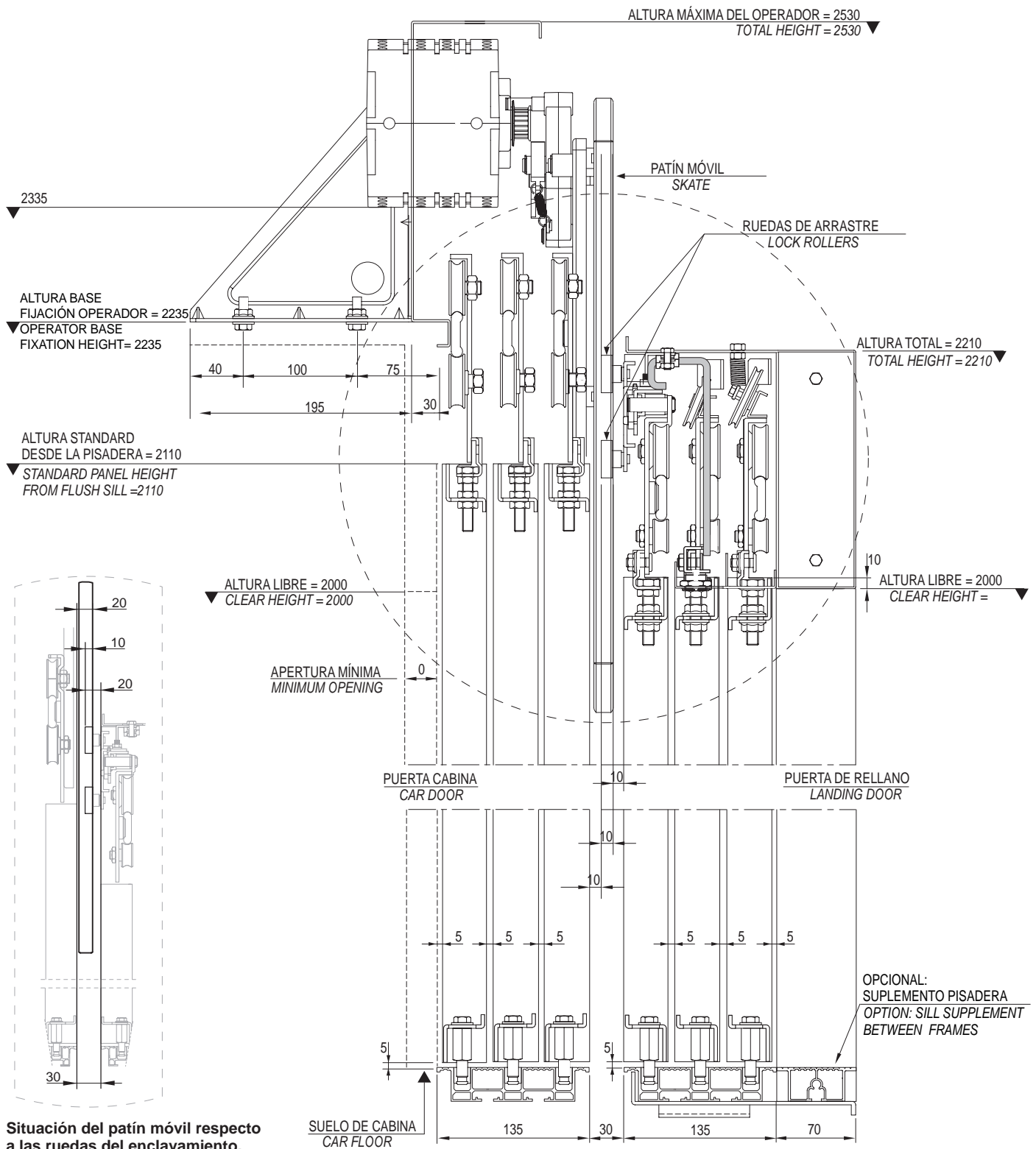

Situación del patín móvil respecto a las ruedas del enclavamiento.

Skate situation in relation to the locking device rollers.

3.8.

SITUACIÓN DEL PATÍN CON LAS RUEDAS DE ARRASTRE COUPLING ARRANGEMENT BETWEEN SKATE AND LOCK

Fermator
AUTOMATIC DOORS FOR LIFTS

Puerta rellano central 6 hojas modelo 50/11 (pisadera 135mm)
6 panel centre parting landing door model 50/11 (sill 135mm)

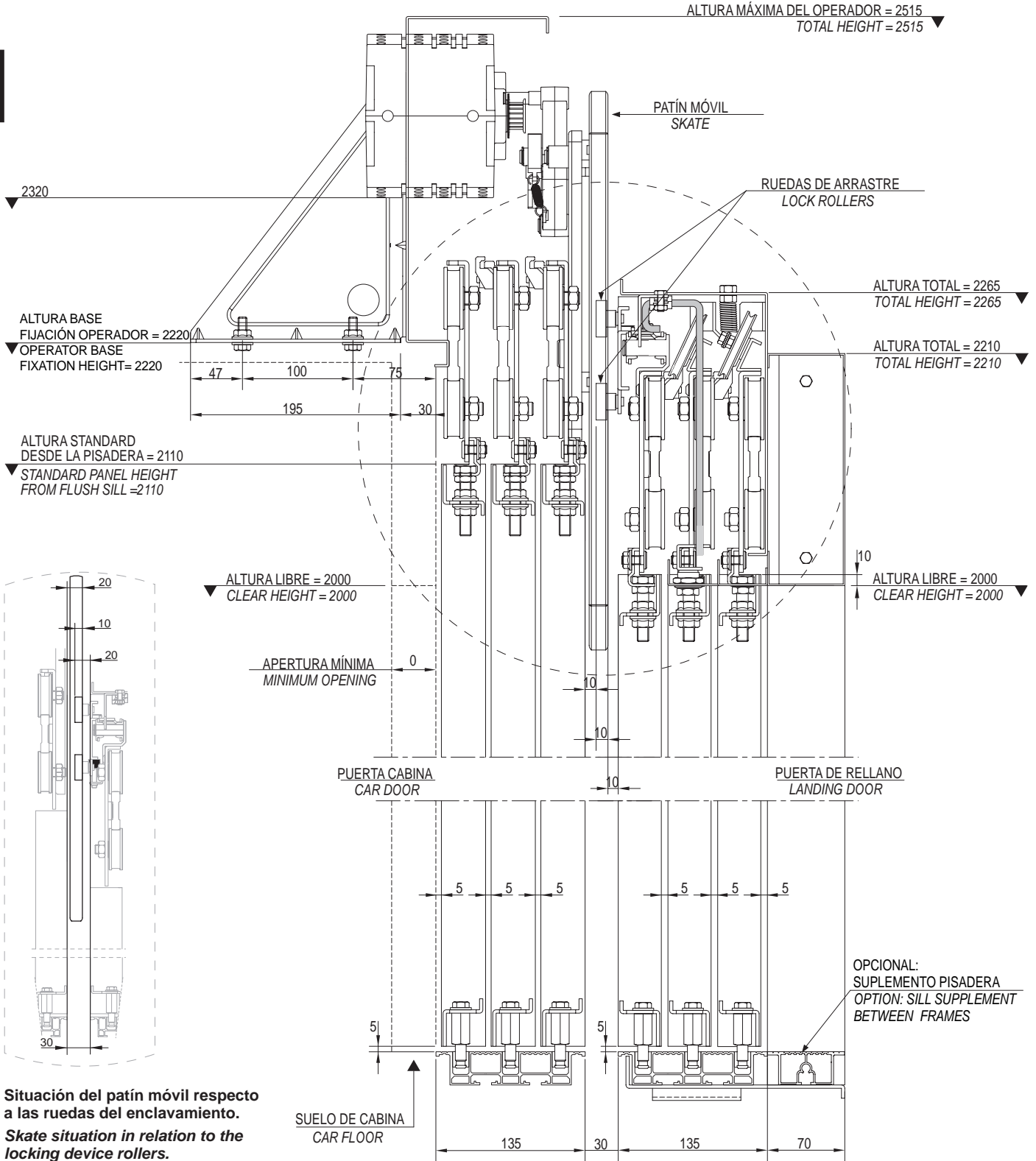

Situación del patín móvil respecto a las ruedas del enclavamiento.
Skate situation in relation to the locking device rollers.

Puerta rellano central 6 hojas modelo 40/10 (pisadera 90mm)
6 panel centre parting landing door model 40/10 (sill 90mm)

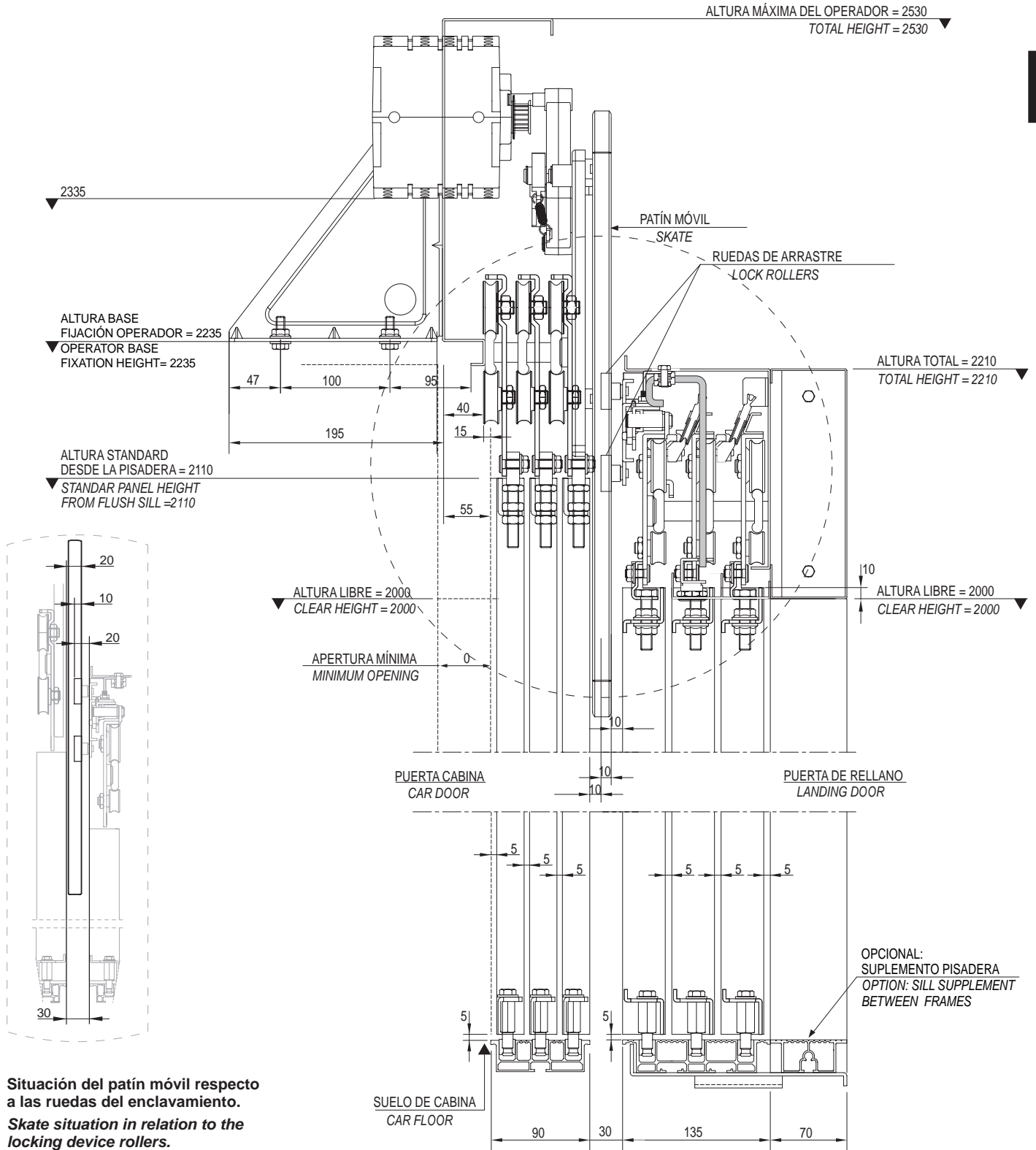

Situación del patín móvil respecto a las ruedas del enclavamiento.
Skate situation in relation to the locking device rollers.

PUERTA CENTRAL DE 8 HOJAS 8 PANEL CENTRE PARTING DOOR

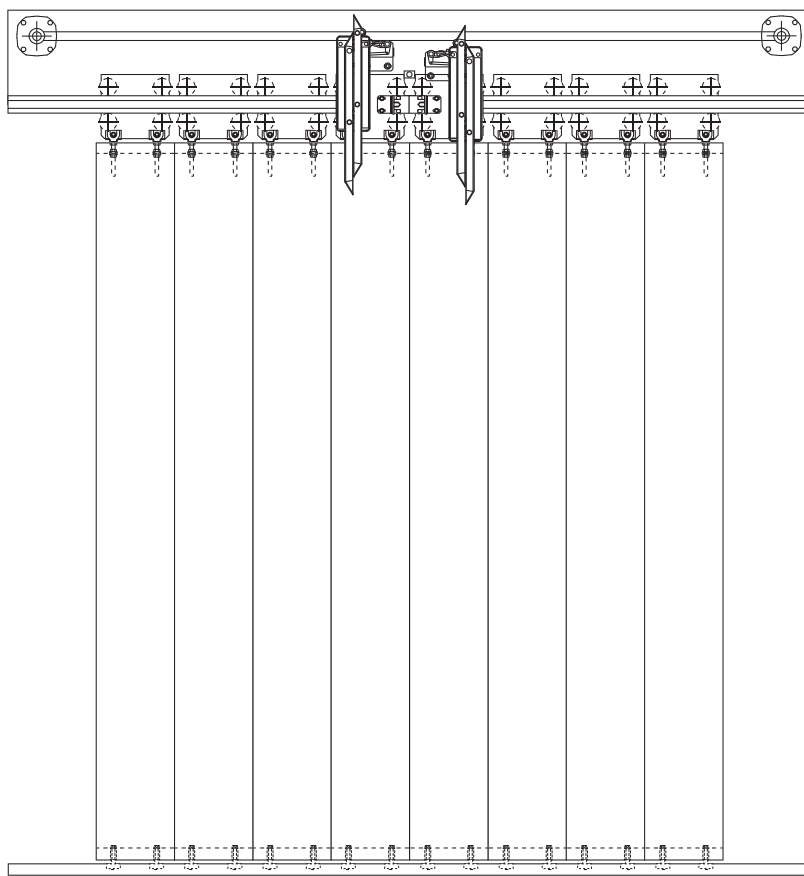

Este modelo no se encuentra disponible en configuración para puertas de relleno automáticas con $PL < 1400$ mm.
This model is not available working together with automatic landing doors with $CO < 1400$ mm.

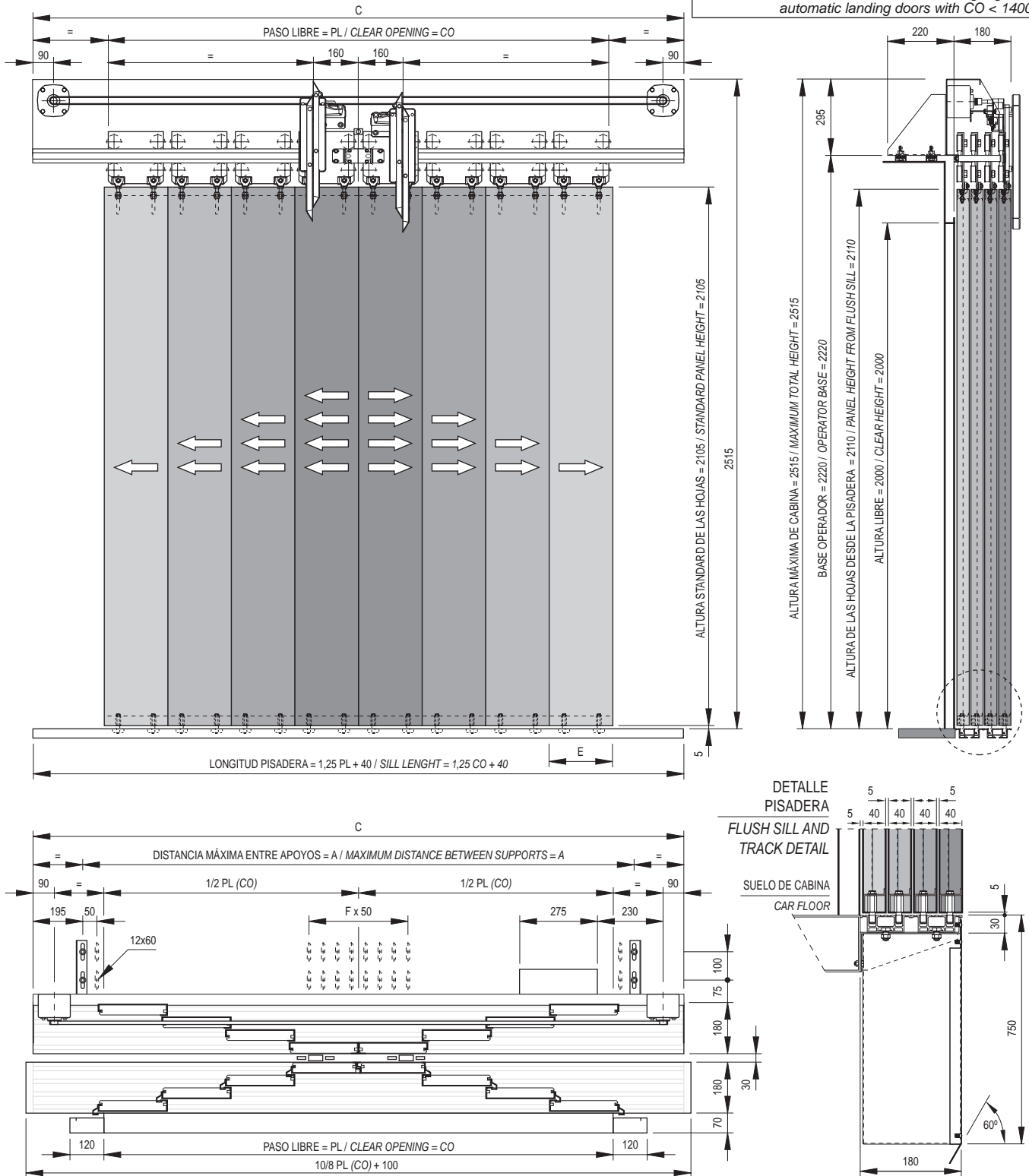

4

Dos Motores / Two Motors

| PL / CO | 1400* | 1500* | 1600 | 1700 | 1800 | 1900 | 2000 | 2100 | 2200 | 2300 | 2400 | 2500 | 2600 | 2700 | 2800 | 2900 | 3000 |
|--------------------|-------|-------|------|------|------|------|------|------|------|-------|-------|-------|------|------|------|------|------|
| A | 1410 | 1535 | 1660 | 1785 | 1910 | 2035 | 2160 | 2285 | 2410 | 2535 | 2660 | 2785 | 2910 | 3035 | 3160 | 3285 | 3410 |
| C | 1800 | 1925 | 2050 | 2175 | 2300 | 2425 | 2550 | 2675 | 2800 | 2925 | 3050 | 3175 | 3300 | 3425 | 3350 | 3675 | 3800 |
| E | 195 | 207 | 220 | 232 | 245 | 257 | 270 | 282 | 295 | 307 | 320 | 332 | 345 | 357 | 370 | 382 | 395 |
| F | 3 | 4 | 4 | 5 | 5 | 6 | 6 | 7 | 7 | 8 | 8 | 9 | 9 | 10 | 10 | 10 | 11 |
| TIEMPO / TIME (s) | 1,73 | 1,8 | 1,87 | 1,94 | 2 | 2,06 | 2,12 | 2,18 | 2,24 | 2,29 | 2,35 | 2,4 | 2,45 | 2,5 | 2,55 | 2,6 | 2,65 |
| PESO / WEIGHT (kg) | 209 | 224 | 239 | 254 | 269 | 284 | 299 | 314 | 329 | 343,5 | 358,5 | 373,5 | 388 | 403 | 418 | 433 | 448 |

*: Consultar con nuestro departamento Técnico - To be consulted to our Technical department.

4.2.

PUERTA RELLANO CENTRAL 8 HOJAS 8 PANEL CENTRE PARTING LANDING DOOR

40/10

Fermator
AUTOMATIC DOORS FOR LIFTS

4

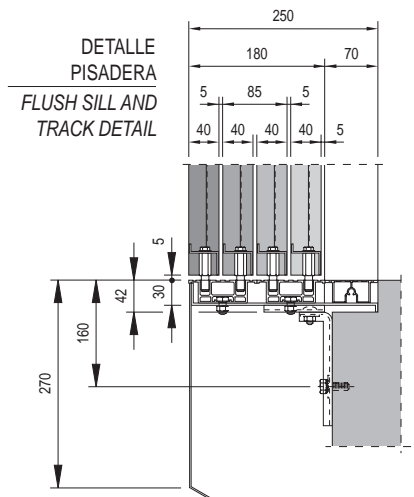
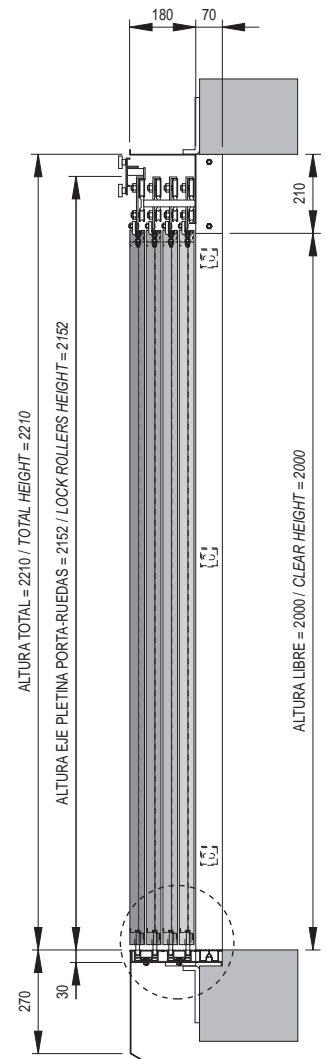
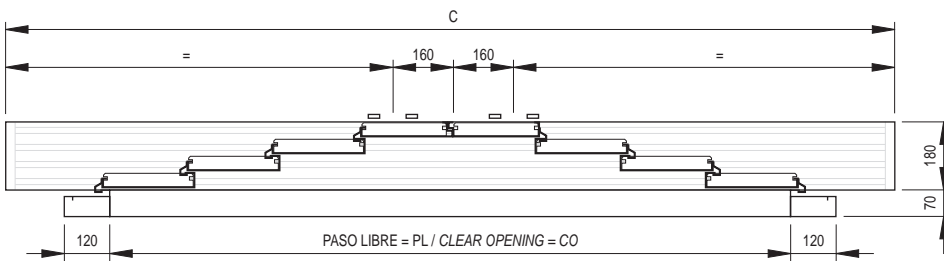
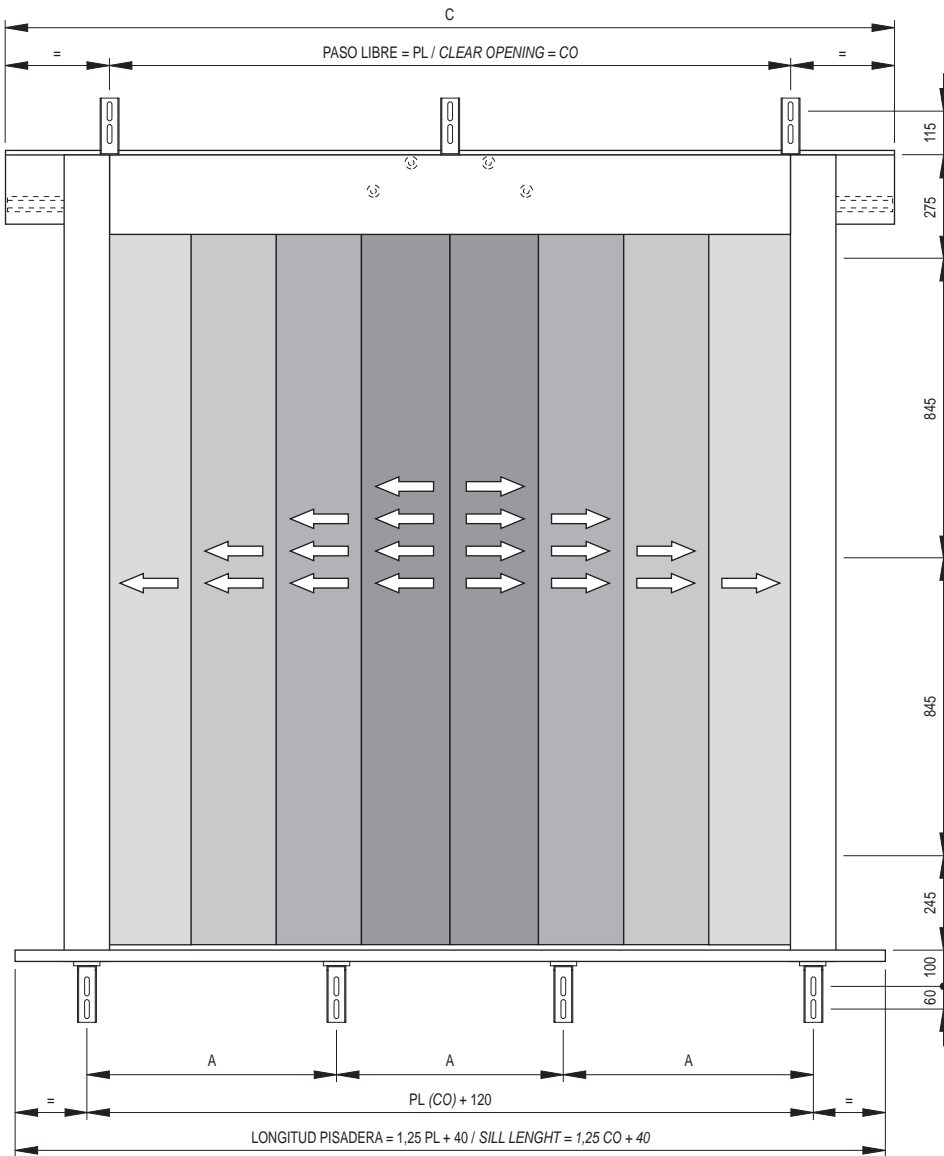

| PL / CO | 1400 | 1500 | 1600 | 1700 | 1800 | 1900 | 2000 | 2100 | 2200 | 2300 | 2400 | 2500 | 2600 | 2700 | 2800 | 2900 | 3000 |
|---------|------|------|------|------|------|------|------|------|------|------|------|------|------|------|------|------|------|
| A | 380 | 324 | 344 | 364 | 384 | 404 | 353 | 370 | 387 | 403 | 360 | 374 | 340 | 352 | 365 | 377 | 390 |
| C | 1850 | 1975 | 2100 | 2225 | 2350 | 2475 | 2600 | 2725 | 2850 | 2975 | 3100 | 3225 | 3350 | 3475 | 3600 | 3725 | 3850 |
| S | 5 | 5 | 6 | 6 | 6 | 6 | 7 | 7 | 7 | 7 | 8 | 8 | 9 | 9 | 9 | 9 | 9 |
| T | 8 | 8 | 9 | 10 | 10 | 10 | 11 | 11 | 11 | 11 | 13 | 13 | 14 | 14 | 14 | 14 | 15 |

S: N° de soportes en apoyo pisadera.
S: Number of supports for sill support.

T: N° de soportes total.
T: Total number of supports.

Puerta con frontis
Door with infill panels

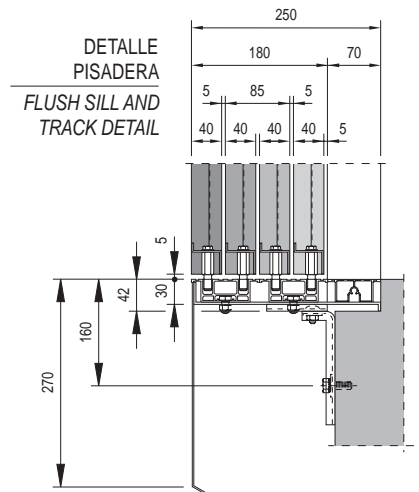
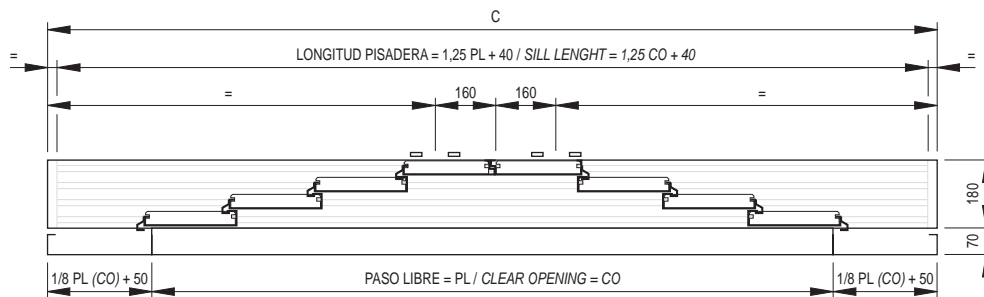
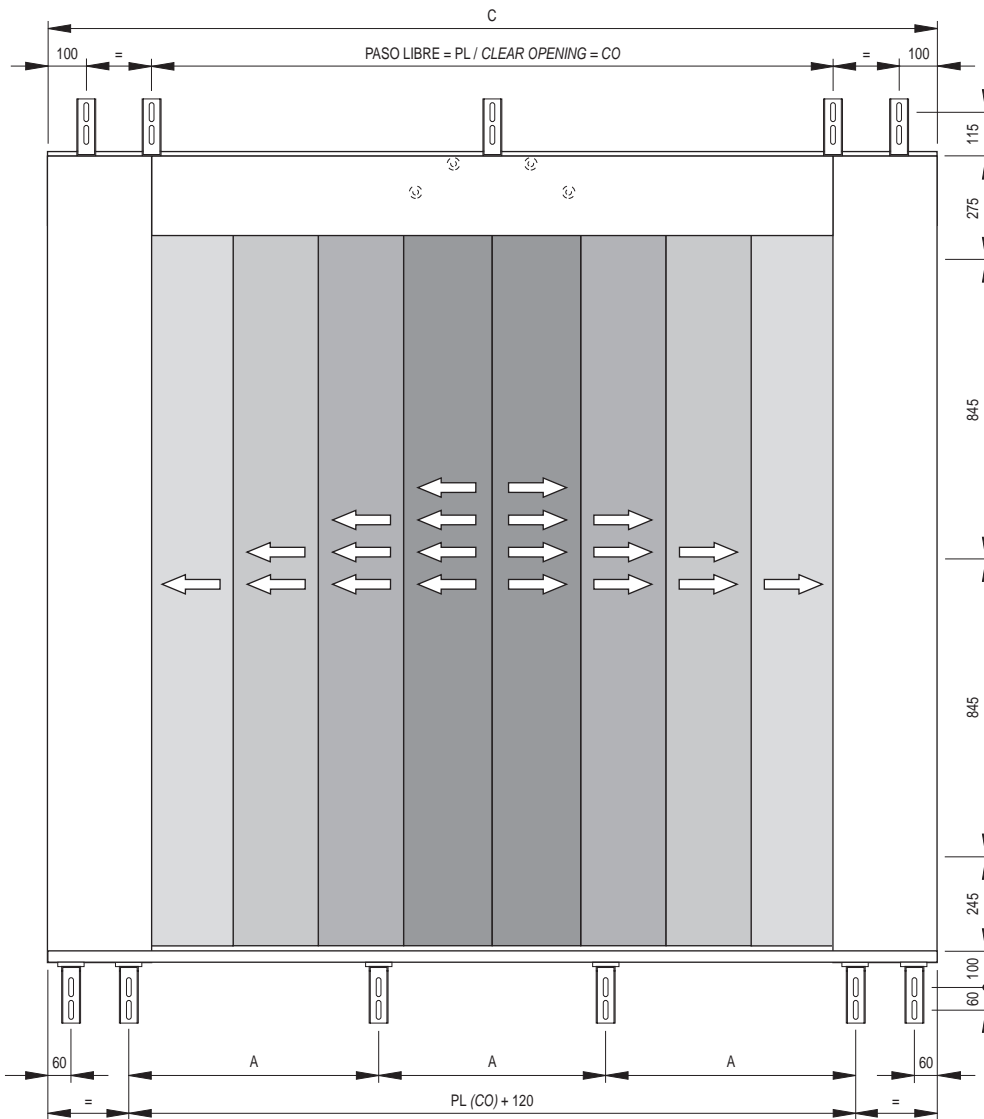

| PL / CO | 1400 | 1500 | 1600 | 1700 | 1800 | 1900 | 2000 | 2100 | 2200 | 2300 | 2400 | 2500 | 2600 | 2700 | 2800 | 2900 | 3000 |
|---------|------|------|------|------|------|------|------|------|------|------|------|------|------|------|------|------|------|
| A | 380 | 324 | 344 | 364 | 384 | 404 | 353 | 370 | 387 | 403 | 360 | 374 | 340 | 352 | 365 | 377 | 390 |
| C | 1850 | 1975 | 2100 | 2225 | 2350 | 2475 | 2600 | 2725 | 2850 | 2975 | 3100 | 3225 | 3350 | 3475 | 3600 | 3725 | 3850 |
| S | 5 | 5 | 6 | 6 | 6 | 6 | 7 | 7 | 7 | 7 | 8 | 8 | 9 | 9 | 9 | 9 | 9 |
| T | 10 | 10 | 11 | 11 | 12 | 12 | 13 | 13 | 13 | 13 | 15 | 15 | 16 | 16 | 16 | 16 | 17 |

S: N° de soportes en apoyo pisadera.
S: Number of supports for sill support.

T: N° de soportes total.
T: Total number of supports.

4

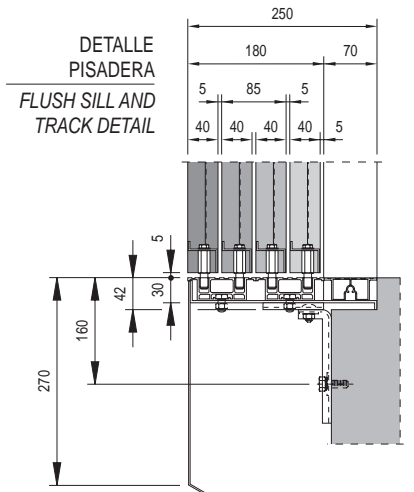
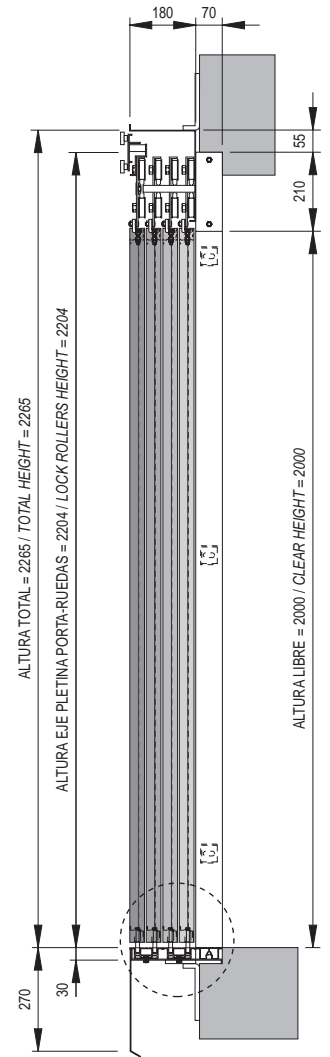
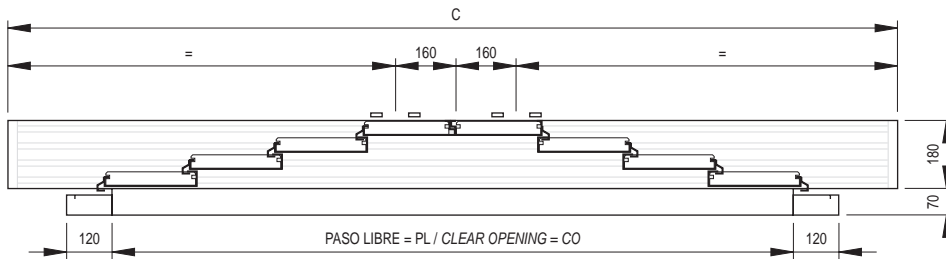
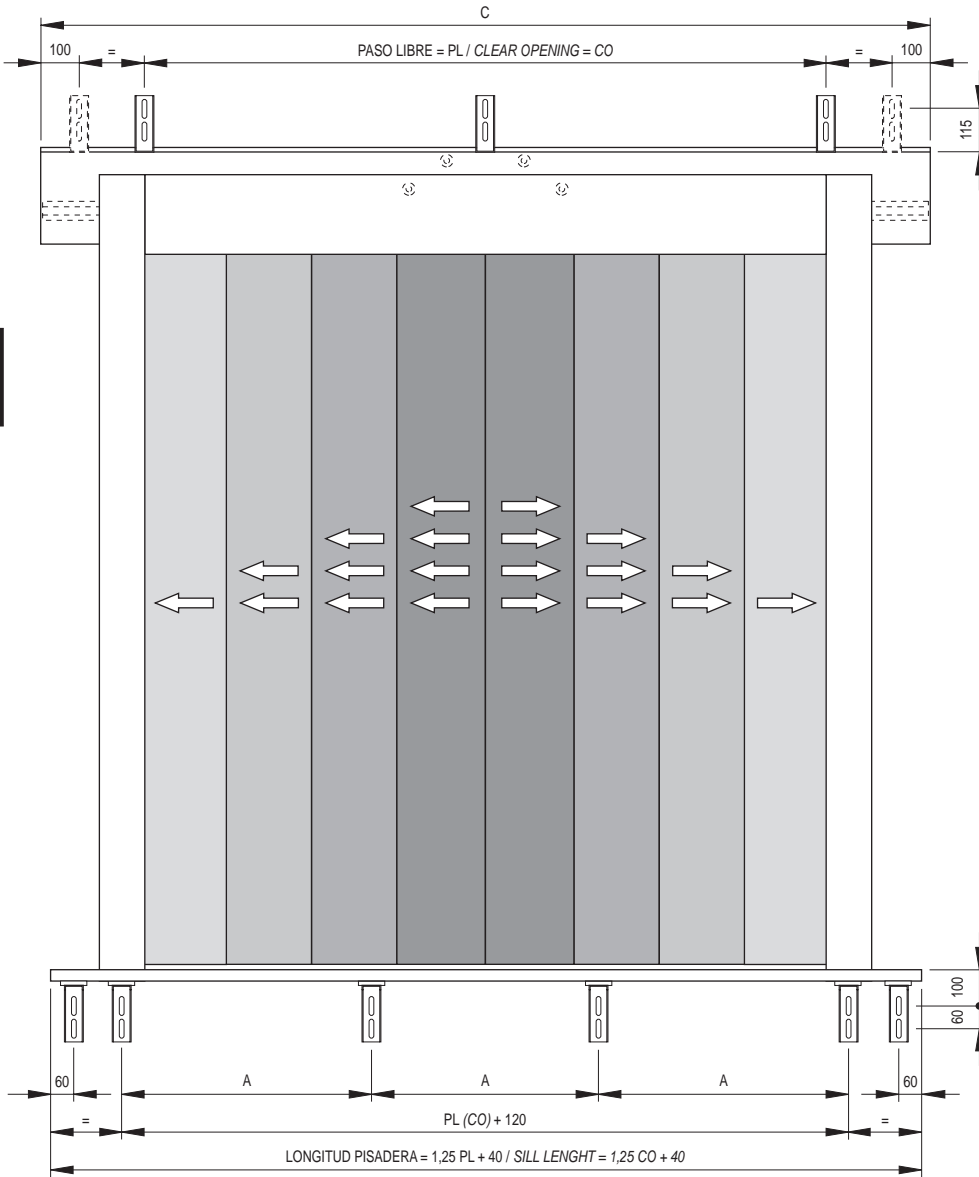

| PL / CO | 1400 | 1500 | 1600 | 1700 | 1800 | 1900 | 2000 | 2100 | 2200 | 2300 | 2400 | 2500 | 2600 | 2700 | 2800 | 2900 | 3000 |
|---------|------|------|------|------|------|------|------|------|------|------|------|------|------|------|------|------|------|
| A | 380 | 324 | 344 | 364 | 384 | 404 | 353 | 370 | 387 | 403 | 360 | 374 | 340 | 352 | 365 | 377 | 390 |
| C | 1850 | 1975 | 2100 | 2225 | 2350 | 2475 | 2600 | 2725 | 2850 | 2975 | 3100 | 3225 | 3350 | 3475 | 3600 | 3725 | 3850 |
| S | 5 | 5 | 6 | 6 | 6 | 6 | 7 | 7 | 7 | 7 | 8 | 8 | 9 | 9 | 9 | 9 | 9 |
| T | 10 | 10 | 11 | 11 | 12 | 12 | 13 | 13 | 13 | 13 | 15 | 15 | 16 | 16 | 16 | 16 | 17 |

S: N° de soportes en apoyo pisadera.
S: Number of supports for sill support.

T: N° de soportes total.
T: Total number of supports.

Puerta rellano central 8 hojas modelo 40/10
8 panel centre parting landing door model 40/10

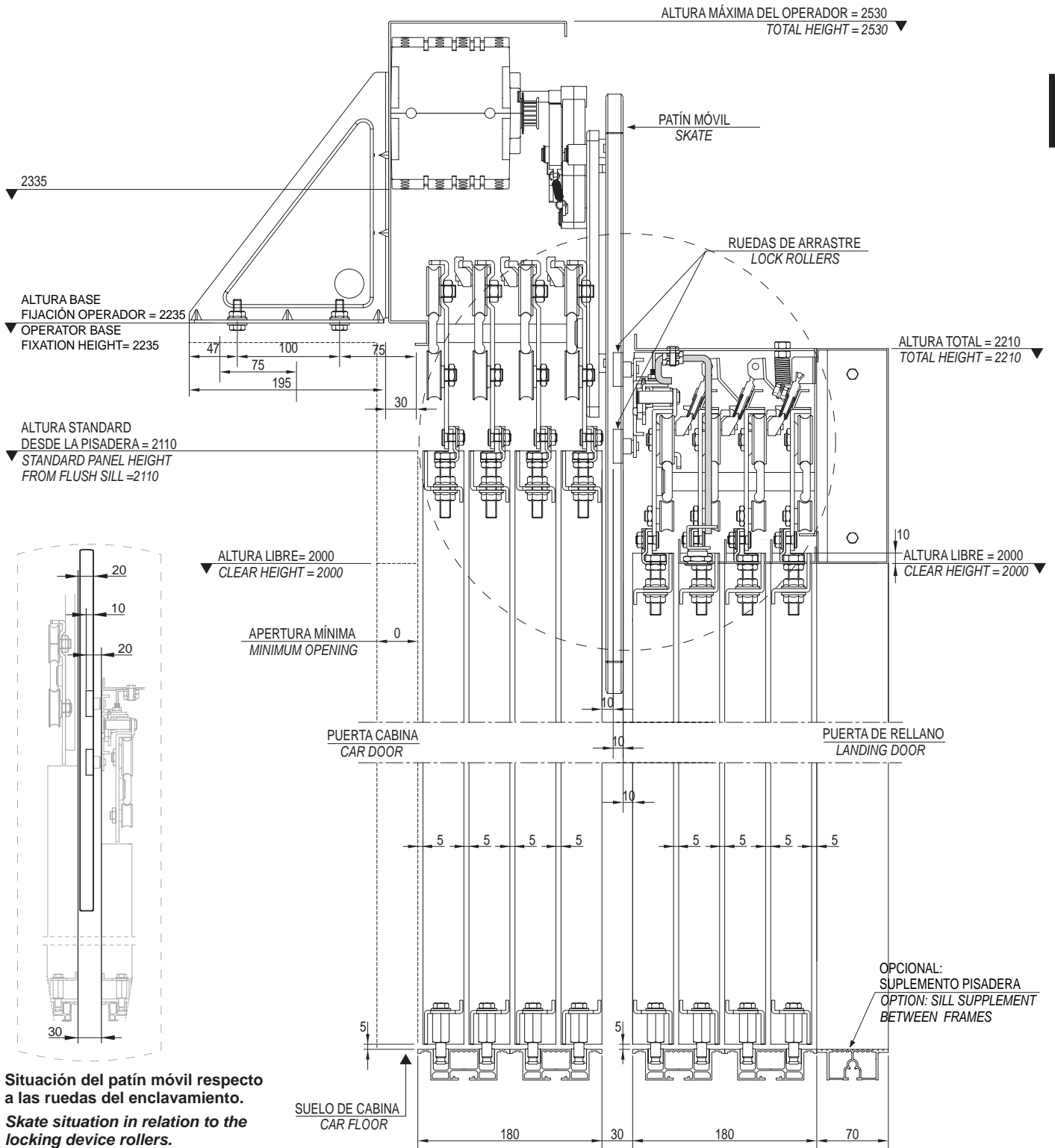

**Situación del patín móvil respecto a las ruedas del enclavamiento.
Skate situation in relation to the locking device rollers.**

Puerta rellano central 8 hojas modelo 50/11
8 panel centre parting landing door model 50/11

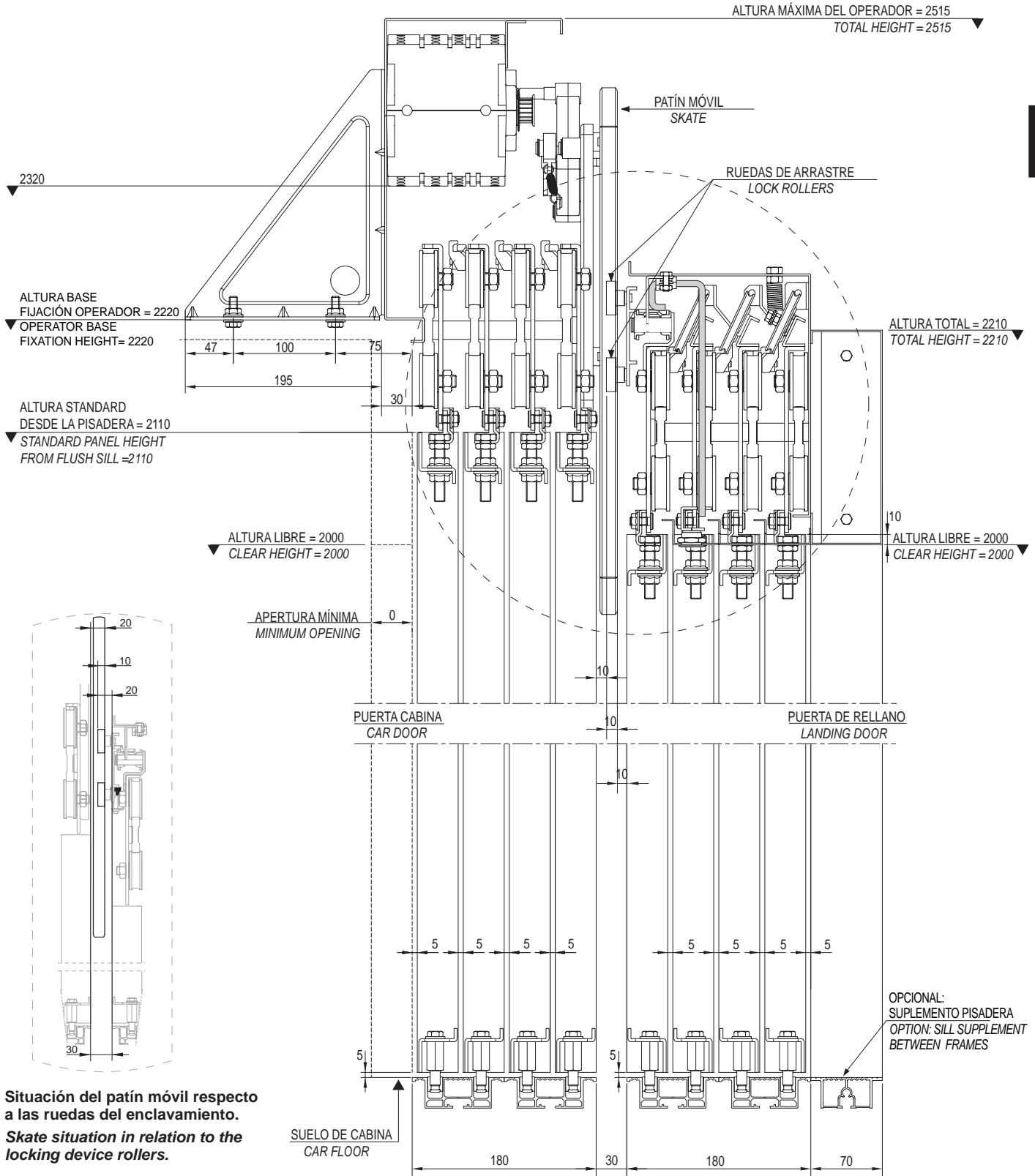

Situación del patín móvil respecto a las ruedas del enclavamiento.
Skate situation in relation to the locking device rollers.

Ferrotec

AUTOMATIC DOORS FOR LIFTS

PUERTA LATERAL DE 1 HOJA
1 PANEL SIDE OPENING DOOR

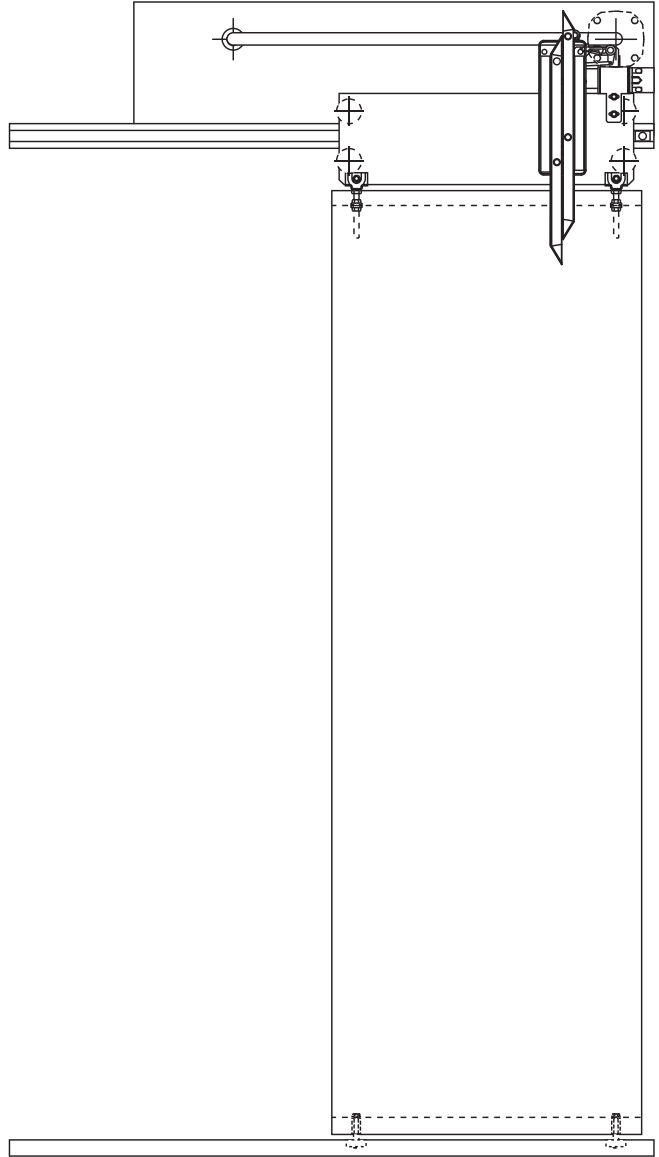

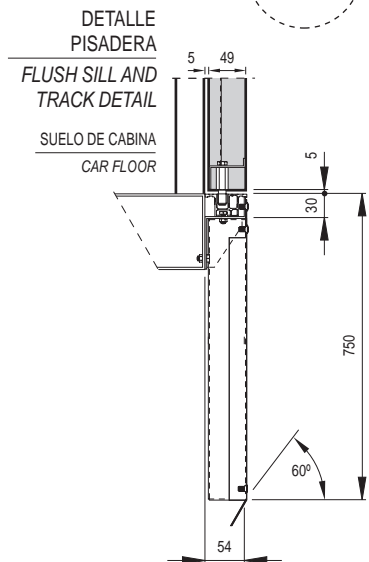
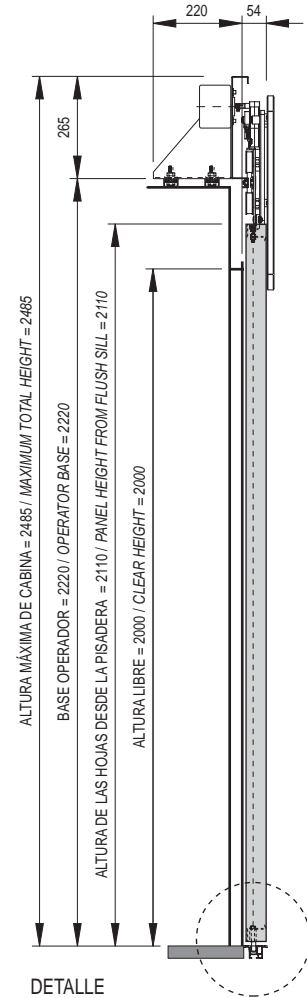
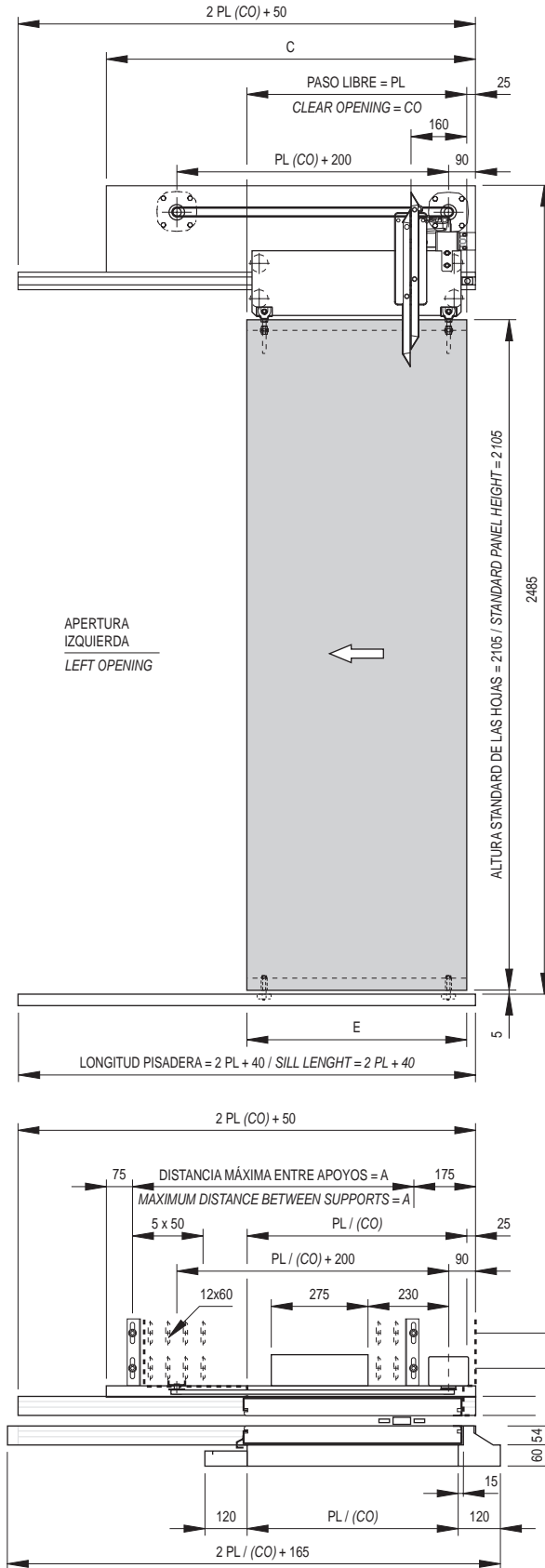

| PL / CO | Un Motor / One Motor | | | | | | | | | | | Dos Motores / Two Motors | | |
|--------------------|----------------------|------|------|------|------|------|------|------|------|------|------|--------------------------|------|------|
| | 600 | 650 | 700 | 750 | 800 | 850 | 900 | 1000 | 1100 | 1200 | 1300 | 1400 | 1500 | 1600 |
| A | 775 | 850 | 925 | 1000 | 1075 | 1150 | 1225 | 1375 | 1525 | 1675 | 1825 | 1975 | 2125 | 2275 |
| C | 1250 | 1350 | 1450 | 1550 | 1650 | 1750 | 1850 | 2050 | 2250 | 2450 | 2650 | 2850 | 3050 | 3250 |
| E | 620 | 670 | 720 | 770 | 820 | 870 | 920 | 1020 | 1120 | 1220 | 1320 | 1420 | 1520 | 1620 |
| TIEMPO / TIME (s) | 0,85 | 0,9 | 0,92 | 0,95 | 0,97 | 1 | 1,15 | 1,3 | 1,45 | 1,6 | 1,75 | 1,9 | 2,05 | 2,2 |
| PESO / WEIGHT (kg) | 54 | 58,5 | 63 | 67,5 | 72 | 76,5 | 81 | 90 | 99 | 108 | 117 | 126 | 135 | 144 |

5.2.

PUERTA RELLANO LATERAL 1 HOJA 1 PANEL SIDE OPENING LANDING DOOR

40/10

Fermator
AUTOMATIC DOORS FOR LIFTS

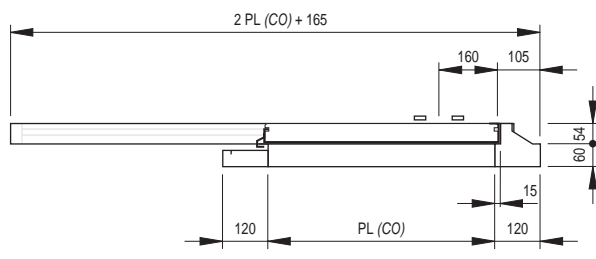
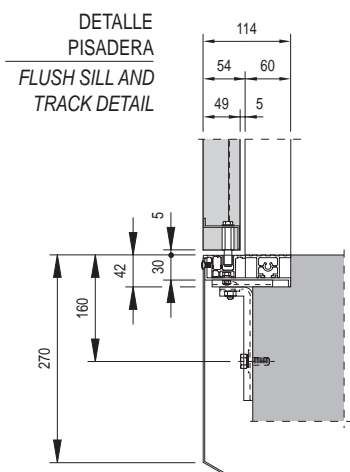
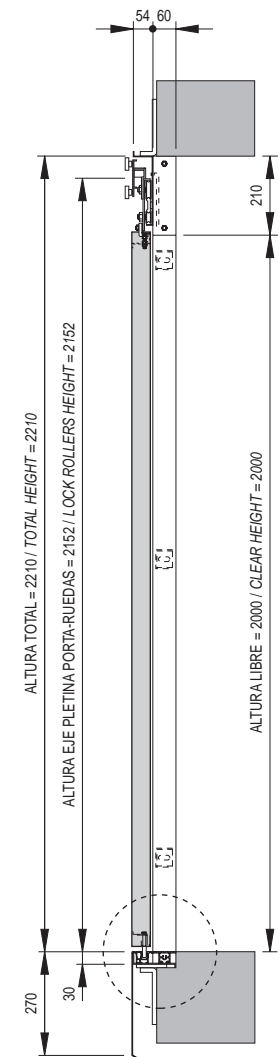
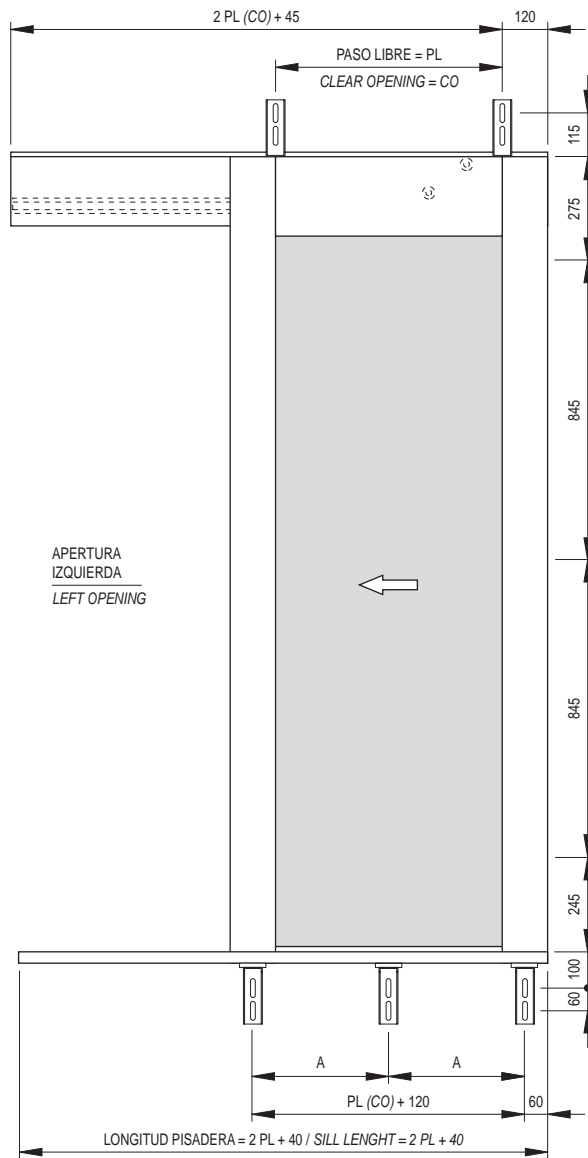

| PL / CO | 600 | 650 | 700 | 750 | 800 | 850 | 900 | 1000 | 1100 | 1200 | 1300 | 1400 |
|---------|------|------|------|------|------|------|------|------|------|------|------|------|
| A | 360 | 385 | 410 | 435 | 460 | 485 | 340 | 373 | 407 | 330 | 355 | 380 |
| C | 1300 | 1400 | 1500 | 1600 | 1700 | 1800 | 1900 | 2100 | 2300 | 2500 | 2700 | 2900 |
| S | 3 | 3 | 3 | 3 | 3 | 3 | 4 | 4 | 4 | 5 | 5 | 5 |
| T | 5 | 5 | 5 | 5 | 5 | 5 | 6 | 6 | 6 | 8 | 8 | 8 |

S: N° de soportes en apoyo pisadera.
S: Number of supports for sill support.

T: N° de soportes total.
T: Total number of supports.

5

Puerta con frontis
Door with infill panels

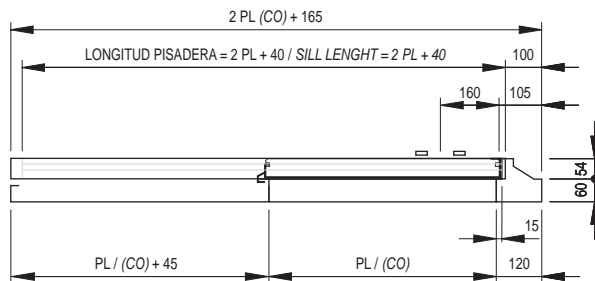
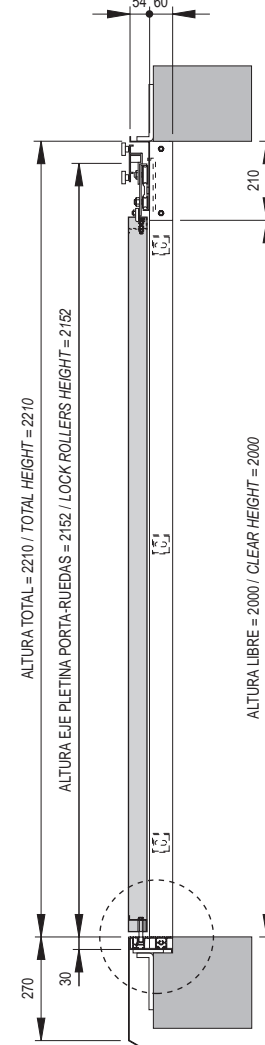
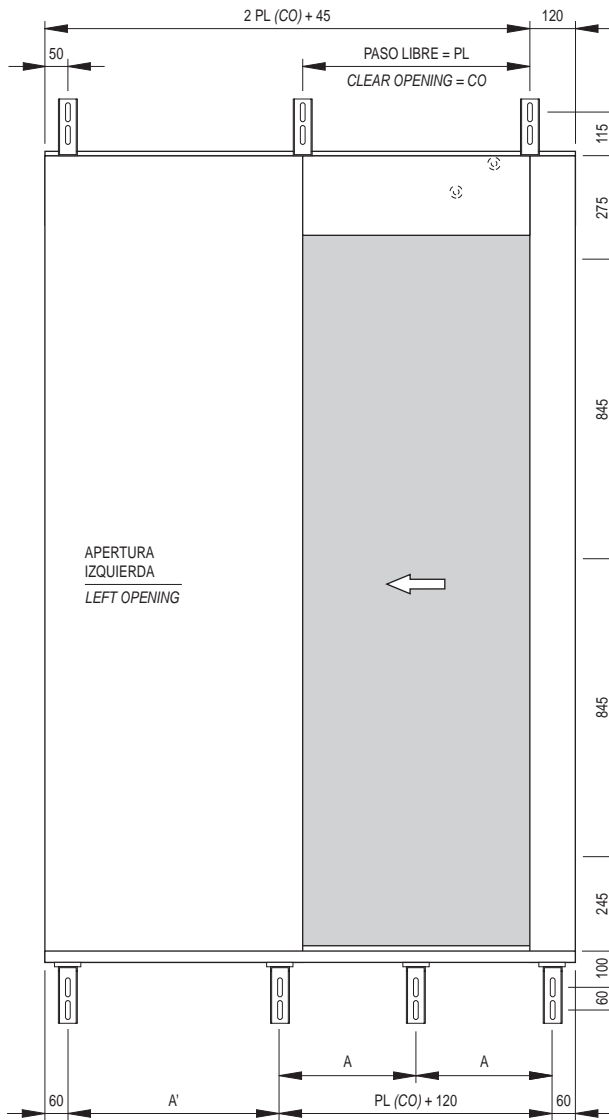

DETALLE
PISADERA
FLUSH SILL AND
TRACK DETAIL

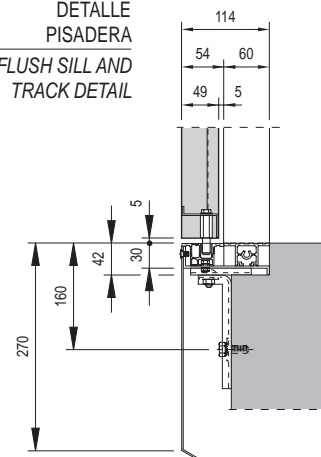

| PL / CO | 600 | 650 | 700 | 750 | 800 | 850 | 900 | 1000 | 1100 | 1200 | 1300 | 1400 |
|---------|------|------|------|------|------|------|------|------|------|------|------|------|
| A | 95 | 95 | 95 | 95 | 95 | 95 | 63 | 63 | 63 | 47 | 47 | 47 |
| A' | 530 | 580 | 630 | 680 | 730 | 780 | 830 | 930 | 1030 | 1130 | 1230 | 1330 |
| C | 1300 | 1400 | 1500 | 1600 | 1700 | 1800 | 1900 | 2100 | 2300 | 2500 | 2700 | 2900 |
| S | 4 | 4 | 4 | 4 | 4 | 4 | 4 | 4 | 4 | 5 | 5 | 5 |
| T | 7 | 7 | 7 | 7 | 7 | 7 | 7 | 7 | 7 | 9 | 9 | 9 |

S: N°. de soportes en apoyo pisadera.
S: Number of supports for sill support.

T: N°. de soportes total.
T: Total number of supports.

5

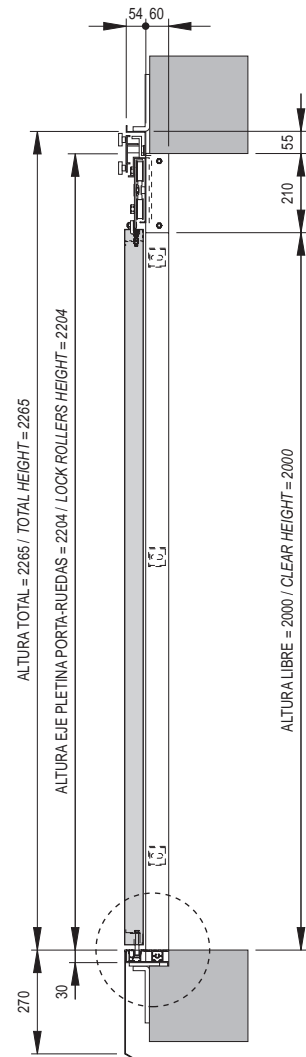
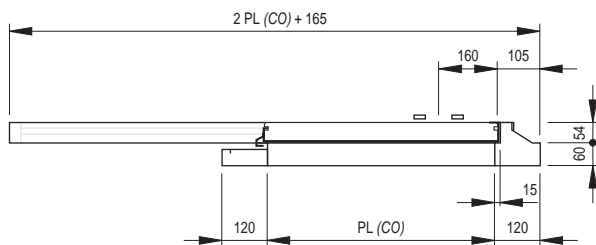
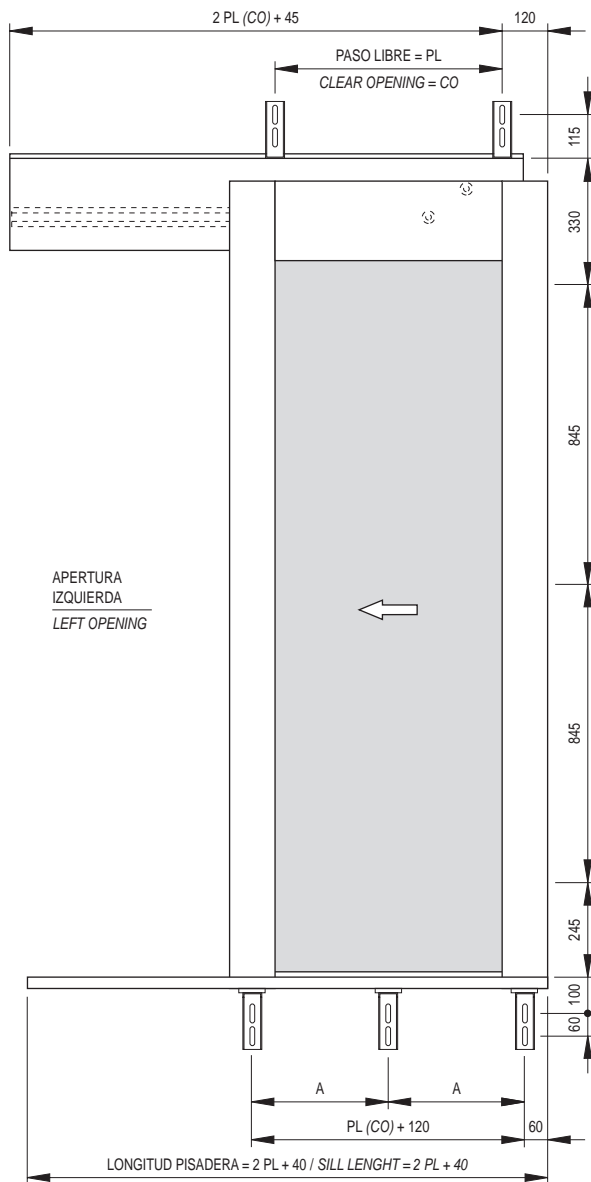

DETALLE
PISADERA
FLUSH SILL AND
TRACK DETAIL

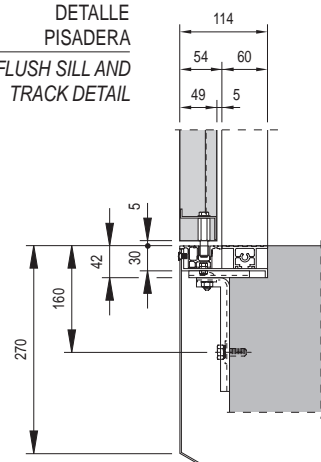

| PL / CO | 600 | 650 | 700 | 750 | 800 | 850 | 900 | 1000 | 1100 | 1200 | 1300 | 1400 | 1500 | 1600 |
|---------|------|------|------|------|------|------|------|------|------|------|------|------|------|------|
| A | 360 | 385 | 410 | 435 | 460 | 485 | 340 | 373 | 407 | 330 | 355 | 380 | 324 | 344 |
| C | 1300 | 1400 | 1500 | 1600 | 1700 | 1800 | 1900 | 2100 | 2300 | 2500 | 2700 | 2900 | 3100 | 3300 |
| S | 3 | 3 | 3 | 3 | 3 | 3 | 4 | 4 | 4 | 5 | 5 | 5 | 6 | 6 |
| T | 5 | 5 | 5 | 5 | 5 | 5 | 6 | 6 | 6 | 8 | 8 | 8 | 9 | 9 |

S: N° de soportes en apoyo pisadera.
S: Number of supports for sill support.

T: N° de soportes total.
T: Total number of supports.

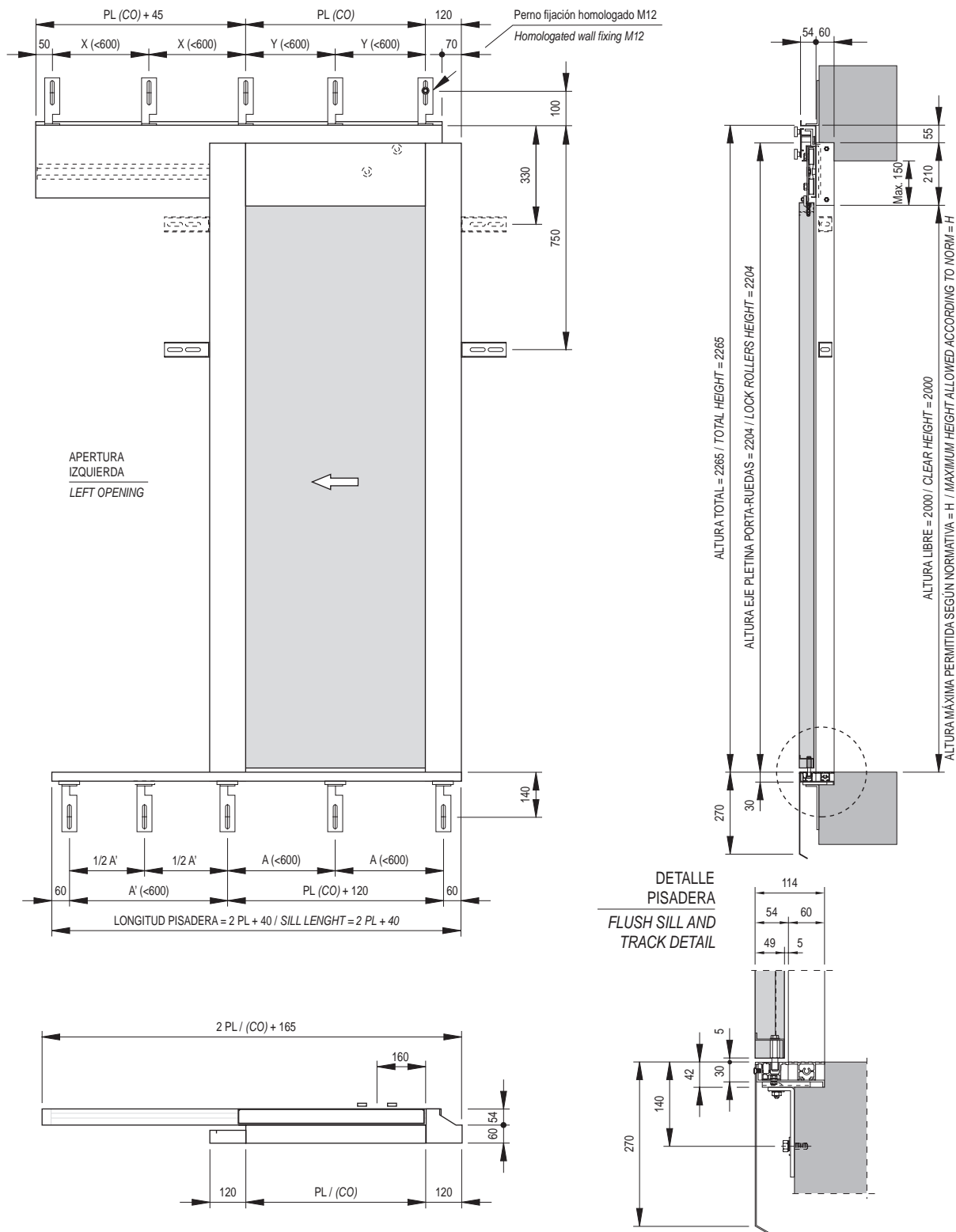

| PL / CO | 600 | 650 | 700 | 750 | 800 | 850 | 900 | 1000 | 1100 | 1200 | 1300 | 1400 | 1500 | 1600 |
|---------|-------|-----|-----|-----|-----|-----|-----|------|------|------|------|------|------|------|
| A | 360 | 385 | 410 | 435 | 460 | 485 | 340 | 373 | 407 | 330 | 355 | 380 | 324 | 344 |
| A' | 585 | 317 | 342 | 367 | 392 | 417 | 442 | 492 | 542 | 592 | 428 | 462 | 495 | 529 |
| X | 600 | 325 | 350 | 375 | 400 | 425 | 450 | 500 | 550 | 600 | 433 | 467 | 500 | 533 |
| Y | 600 | 325 | 350 | 375 | 400 | 425 | 450 | 500 | 550 | 600 | 433 | 467 | 500 | 533 |
| R | 3 | 5 | 5 | 5 | 6 | 6 | 6 | 6 | 6 | 6 | 8 | 8 | 8 | 8 |
| H | ≤2500 | | | | | | | | | | | | | |
| S | 4 | 5 | 5 | 5 | 5 | 5 | 6 | 6 | 6 | 7 | 8 | 8 | 9 | 9 |
| T | 9 | 12 | 12 | 12 | 13 | 13 | 14 | 14 | 14 | 15 | 18 | 18 | 19 | 19 |

□ Puertas homologadas TÜV (DIN 18091). R: N°. de soportes en mecanismo de rellano. S: N°. de soportes en apoyo pisadera. T: N°. de soportes total.
 □ Doors certified by TÜV (DIN 18091) R: Number of supports for landing mechanism. S: Number of supports for sill support. T: Total number of supports.

5.6.

SITUACIÓN DEL PATÍN CON LAS RUEDAS DE ARRASTRE COUPLING ARRANGEMENT BETWEEN SKATE AND LOCK

Fermator
AUTOMATIC DOORS FOR LIFTS

Puerta rellano lateral 1 hoja modelo 40/10
1 panel side opening landing door model 40/10

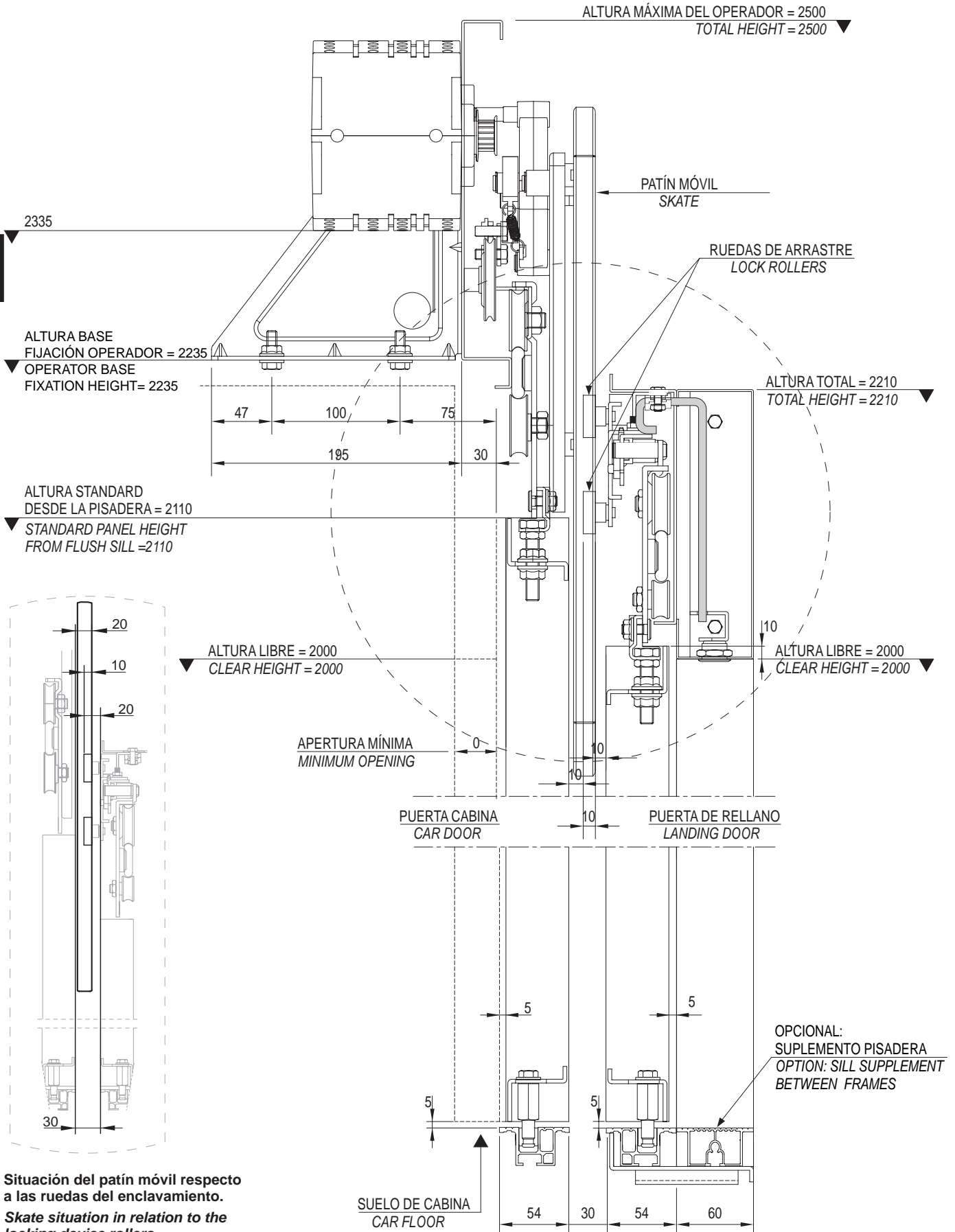

Situación del patín móvil respecto a las ruedas del enclavamiento.
Skate situation in relation to the locking device rollers.

Puerta rellano lateral 1 hoja modelo 50/11
1 panel side opening landing door model 50/11

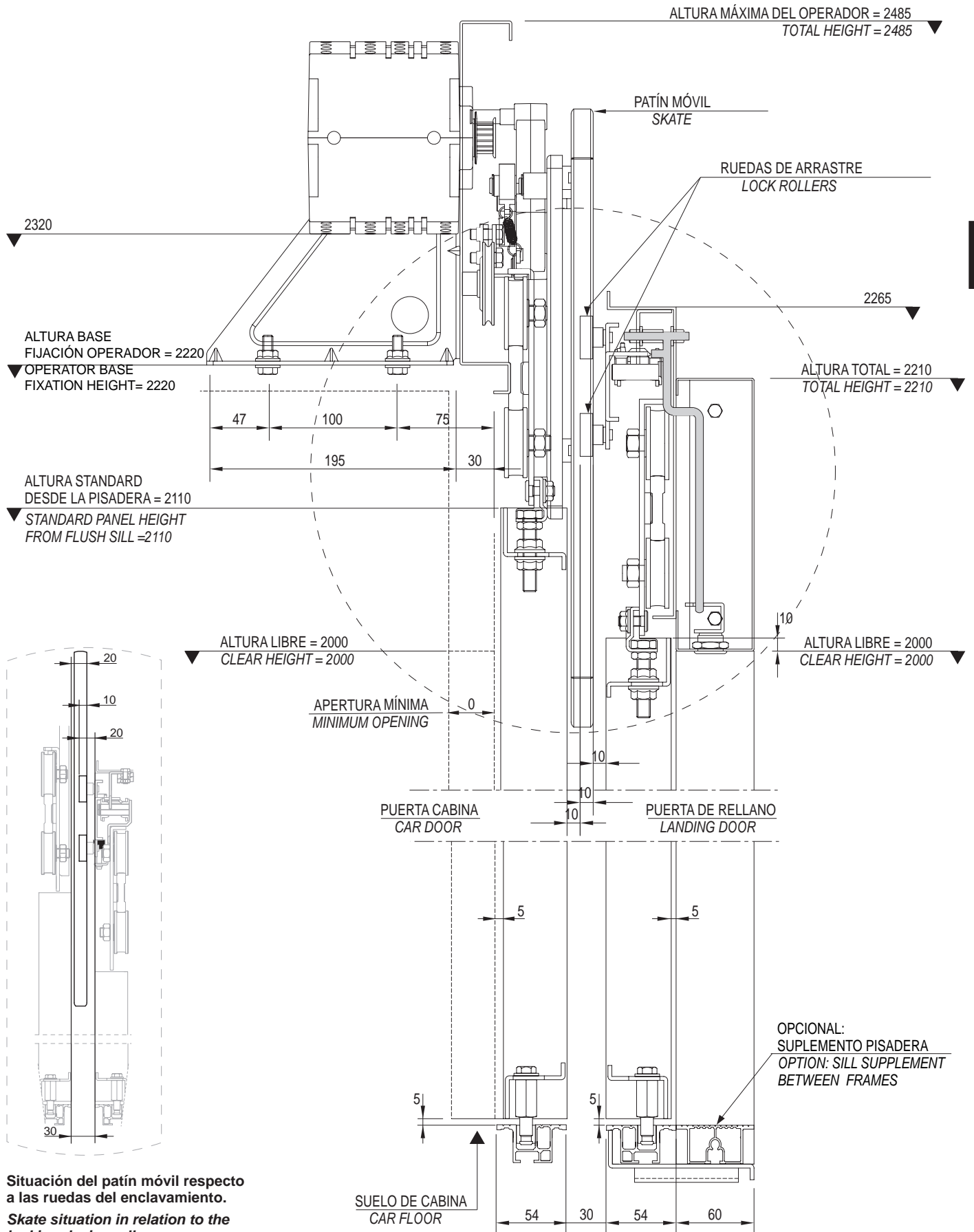

Situación del patín móvil respecto a las ruedas del enclavamiento.
Skate situation in relation to the locking device rollers.

Ferrotec

AUTOMATIC DOORS FOR LIFTS

PUERTA TELESCÓPICA DE 2 HOJAS
2 PANEL SIDE OPENING DOOR

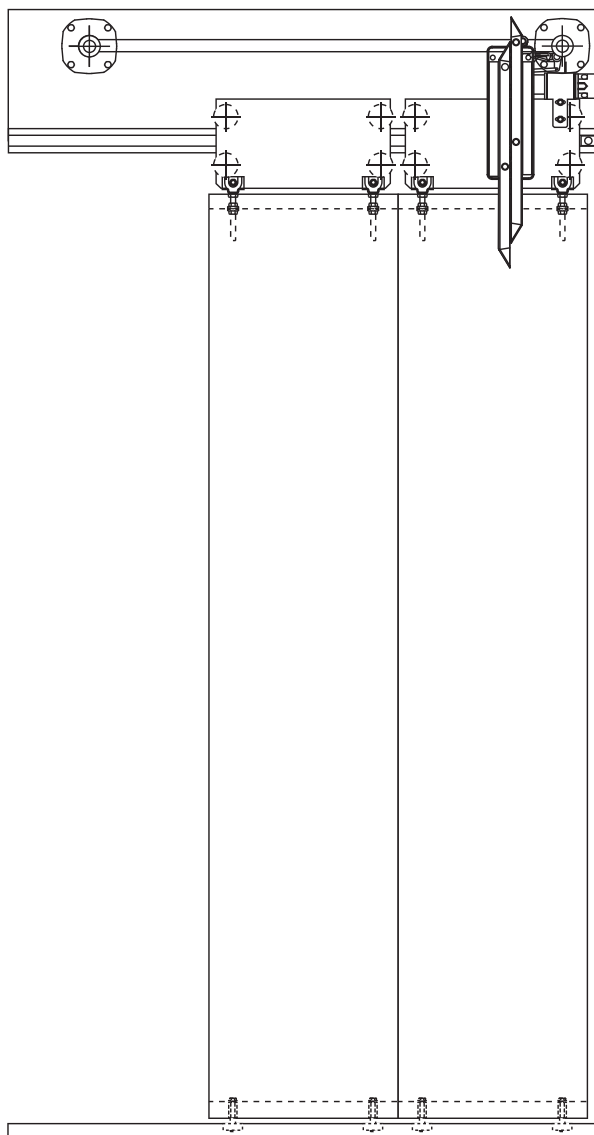

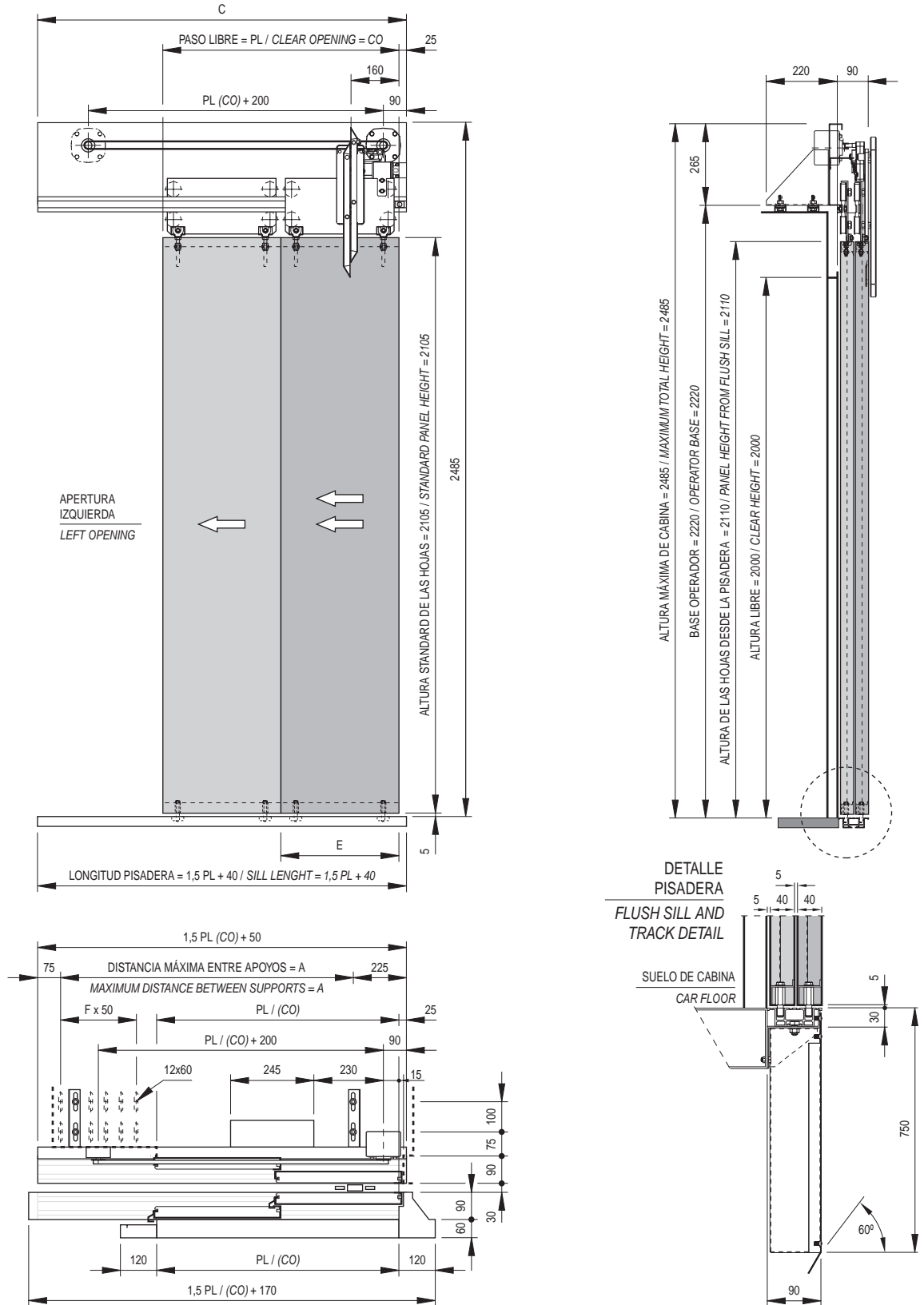

| PL / CO | Un Motor / One Motor | | | | | | | | | | | Dos Motores / Two Motors | | |
|--------------------|----------------------|------|------|------|------|------|------|------|------|------|------|--------------------------|-------|------|
| | 600 | 650 | 700 | 750 | 800 | 850 | 900 | 1000 | 1100 | 1200 | 1300 | 1400 | 1500 | 1600 |
| A | 650 | 725 | 800 | 875 | 950 | 1025 | 1100 | 1250 | 1400 | 1550 | 1700 | 1850 | 2000 | 2150 |
| C | 950 | 1025 | 1100 | 1175 | 1250 | 1325 | 1400 | 1550 | 1700 | 1850 | 2000 | 2150 | 2300 | 2450 |
| E | 320 | 345 | 370 | 395 | 420 | 445 | 470 | 520 | 570 | 620 | 670 | 720 | 770 | 820 |
| F | 4 | 4 | 5 | 5 | 6 | 6 | 6 | 7 | 8 | 8 | 8 | 8 | 9 | 9 |
| TIEMPO / TIME (s) | 1,56 | 1,62 | 1,68 | 1,74 | 1,8 | 1,85 | 1,91 | 2,01 | 2,11 | 2,2 | 2,3 | 2,4 | 2,5 | 2,6 |
| PESO / WEIGHT (kg) | 52,5 | 57 | 61,5 | 66 | 70 | 74,5 | 79 | 87,5 | 96,5 | 105 | 114 | 122,5 | 131,5 | 140 |

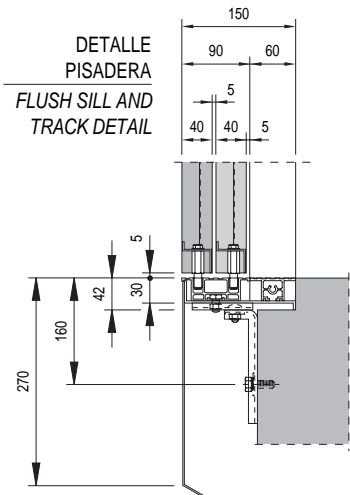
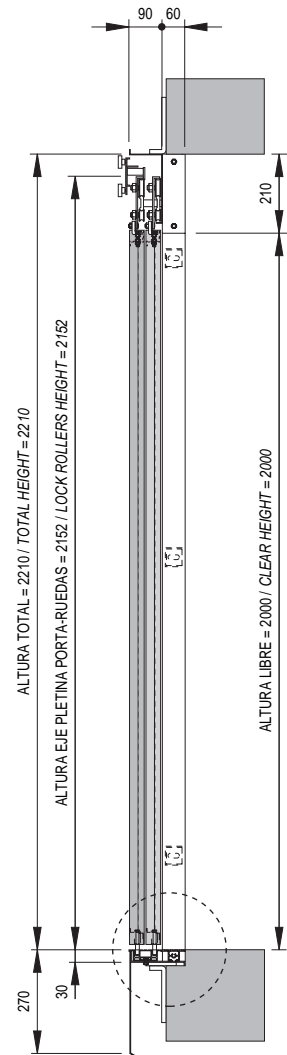
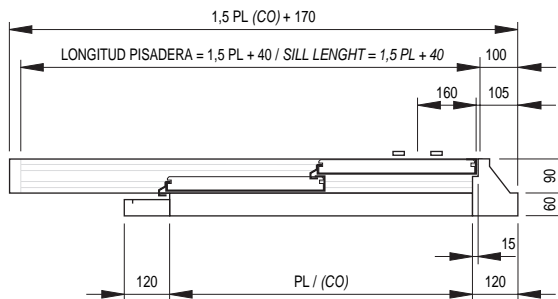
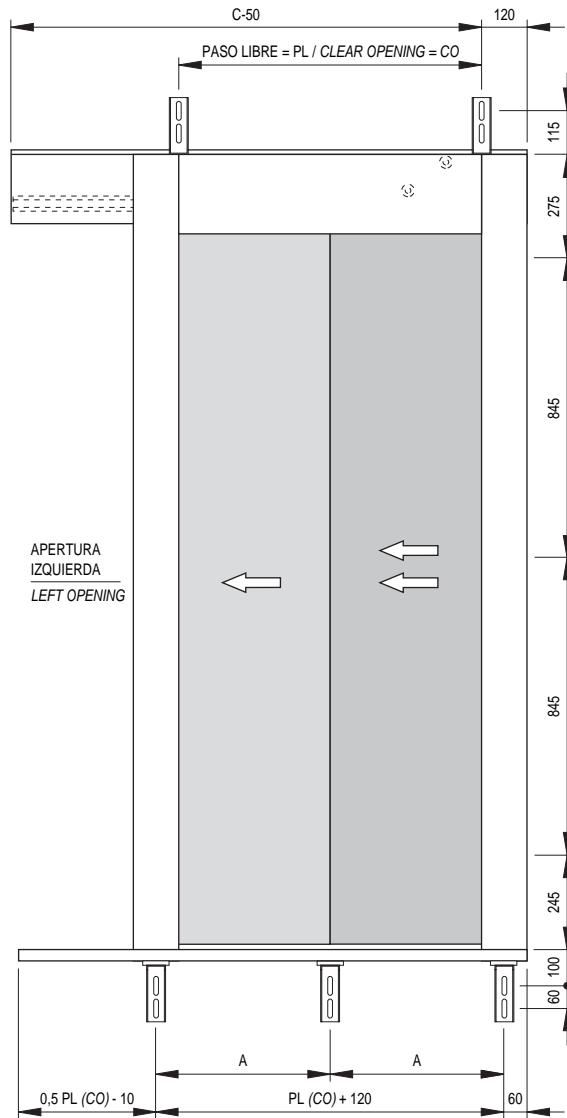

| PL / CO | 600 | 650 | 700 | 750 | 800 | 850 | 900 | 1000 | 1100 | 1200 | 1300 | 1400 |
|---------|------|------|------|------|------|------|------|------|------|------|------|------|
| C | 1000 | 1075 | 1150 | 1225 | 1300 | 1375 | 1450 | 1600 | 1750 | 1900 | 2050 | 2200 |
| A | 360 | 385 | 410 | 435 | 460 | 485 | 340 | 373 | 407 | 330 | 355 | 380 |
| S | 3 | 3 | 3 | 3 | 3 | 3 | 4 | 4 | 4 | 5 | 5 | 5 |
| T | 5 | 5 | 5 | 5 | 5 | 5 | 6 | 6 | 6 | 8 | 8 | 8 |

S: N° de soportes en apoyo pisadera.
S: Number of supports for sill support.

T: N° de soportes total.
T: Total number of supports.

Puerta con frontis
Door with infill panels

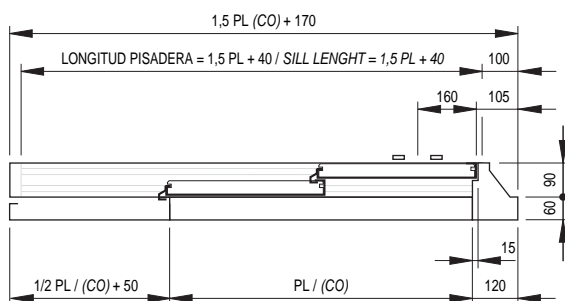
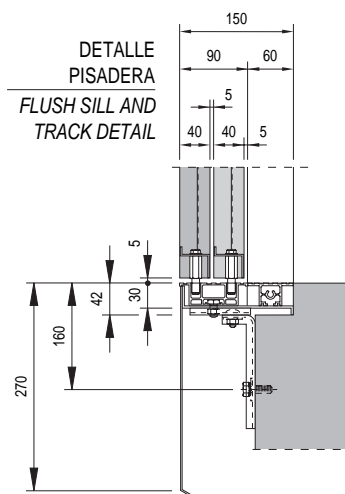
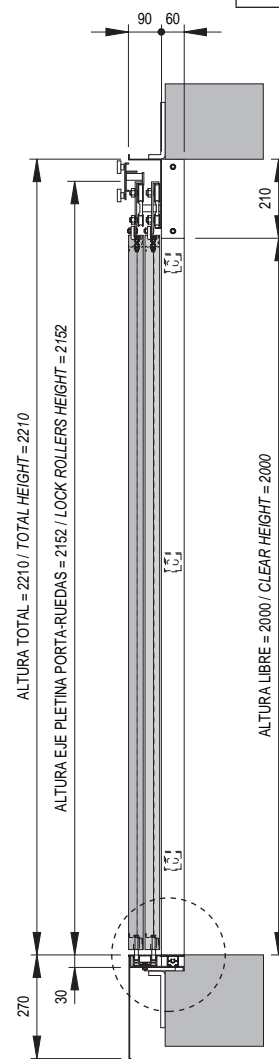
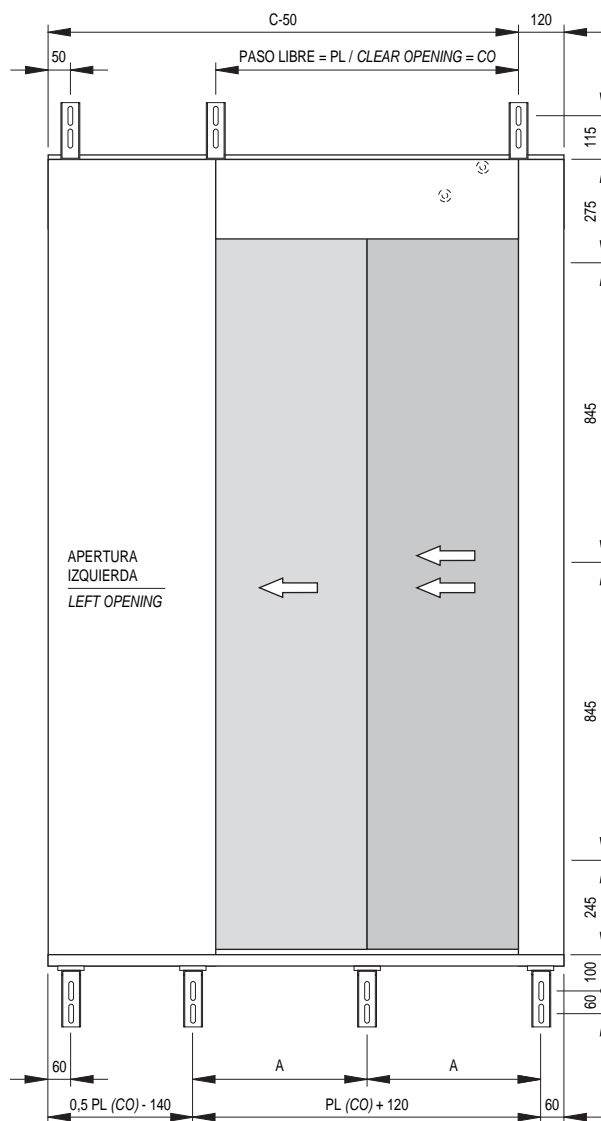

| PL / CO | 600 | 650 | 700 | 750 | 800 | 850 | 900 | 1000 | 1100 | 1200 | 1300 | 1400 |
|---------|------|------|------|------|------|------|------|------|------|------|------|------|
| C | 1000 | 1075 | 1150 | 1225 | 1300 | 1375 | 1450 | 1600 | 1750 | 1900 | 2050 | 2200 |
| A | 360 | 385 | 410 | 435 | 460 | 485 | 340 | 373 | 407 | 330 | 355 | 380 |
| S | 3 | 3 | 3 | 3 | 3 | 3 | 4 | 4 | 4 | 5 | 5 | 5 |
| T | 6 | 6 | 6 | 6 | 6 | 6 | 7 | 7 | 7 | 9 | 9 | 9 |

S: N°. de soportes en apoyo pisadera.
S: Number of supports for sill support.

T: N°. de soportes total.
T: Total number of supports.

6.4.

PUERTA RELANO TElescÓPICA 2 HOJAS 2 PANEL SIDE OPENING LANDING DOOR

40/10
DIN 18.091

Fermator
AUTOMATIC DOORS FOR LIFTS

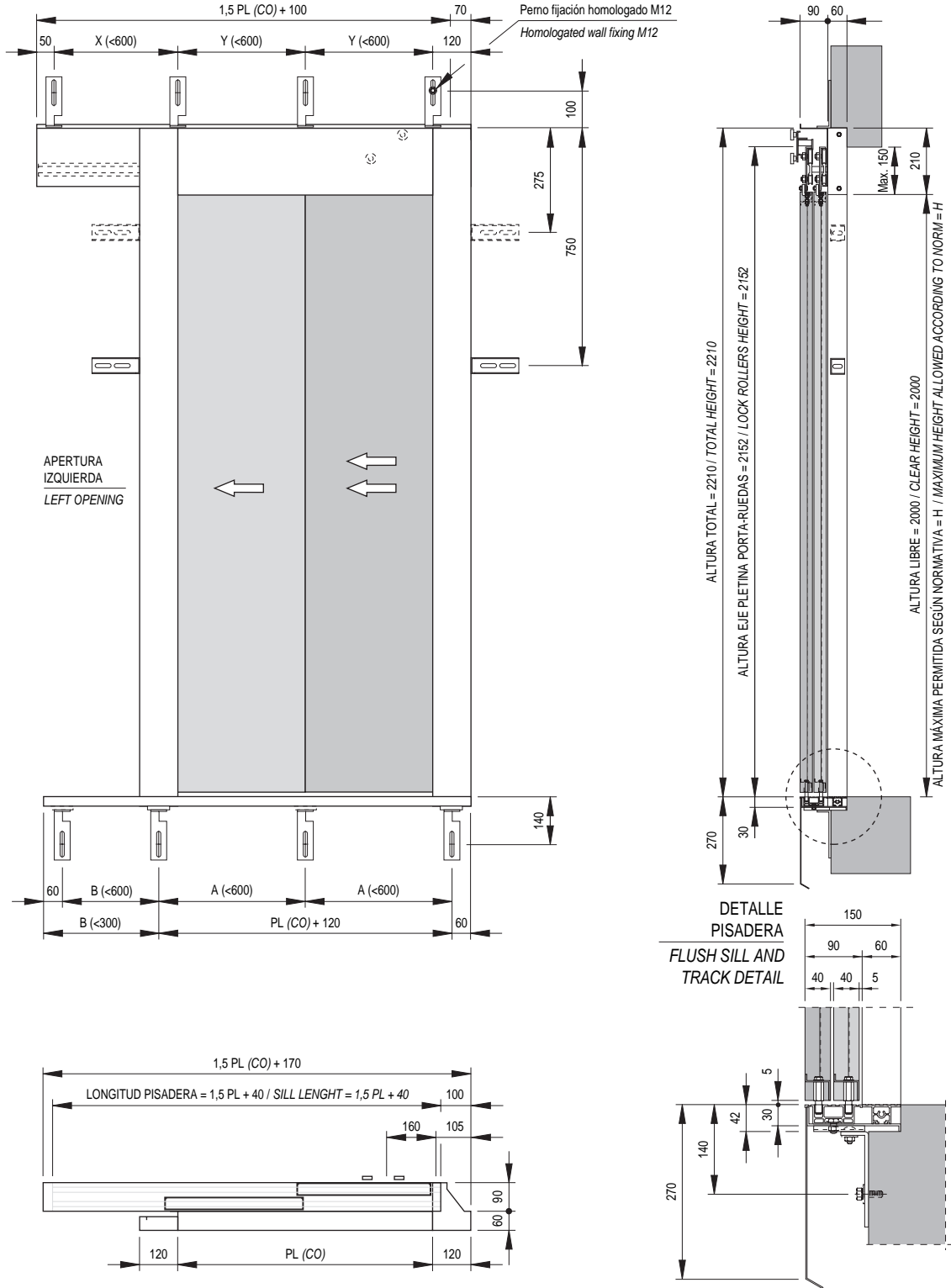

6

| PL / CO | 600 | 650 | 700 | 750 | 800 | 850 | 900 | 1000 | 1100 | 1200 | 1300 | 1400 |
|---------|--------|-----|-----|-----|-----|-----|-----|------|------|------|------|------|
| A | 360 | 385 | 410 | 435 | 460 | 485 | 340 | 373 | 407 | 330 | 355 | 380 |
| A' | 280 | 245 | 270 | 295 | 320 | 345 | 370 | 420 | 470 | 520 | 580 | 315 |
| X | 300 | 325 | 350 | 375 | 400 | 425 | 450 | 500 | 550 | 600 | 325 | 350 |
| Y | 600 | 325 | 350 | 375 | 400 | 425 | 450 | 500 | 550 | 600 | 433 | 466 |
| H | ≤ 2500 | | | | | | | | | | | |
| R | 3 | 4 | 4 | 4 | 4 | 4 | 4 | 4 | 4 | 4 | 6 | 6 |
| S | 3 | 4 | 4 | 4 | 4 | 4 | 5 | 5 | 5 | 6 | 6 | 7 |
| T | 8 | 10 | 10 | 10 | 10 | 10 | 11 | 11 | 11 | 12 | 14 | 15 |

- Puertas homologadas TÜV (DIN 18091).
R: N°. de soportes en mecanismo de rellano.
S: N°. de soportes en apoyo pisadera.
T: N°. de soportes total.
- Doors certified by TÜV (DIN 18091).
R: Number of supports for landing mechanism.
S: Number of supports for sill support.
T: Total number of supports.

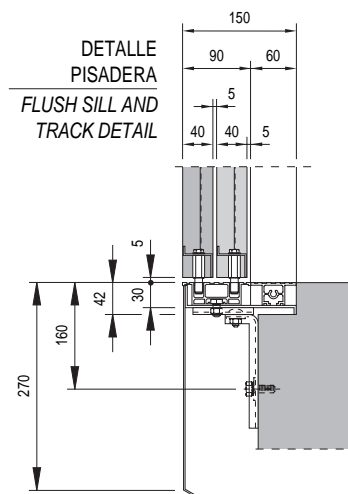
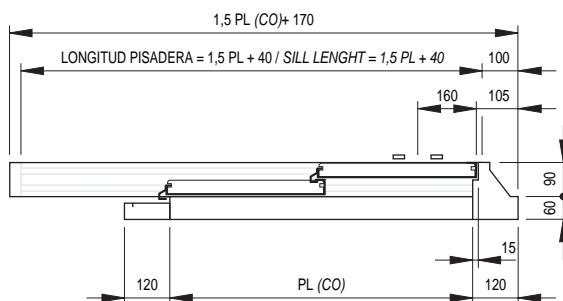
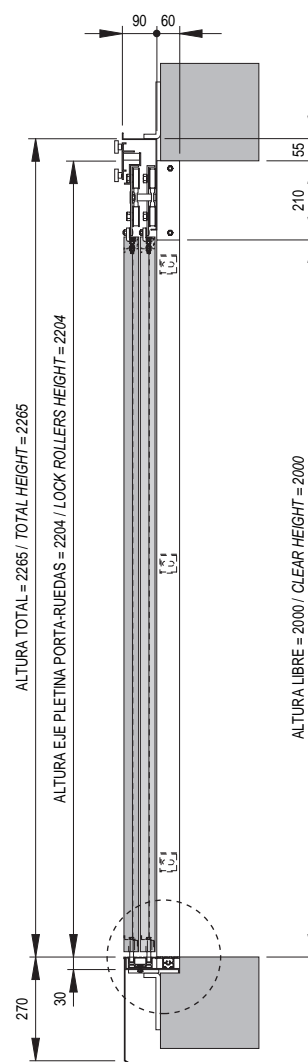
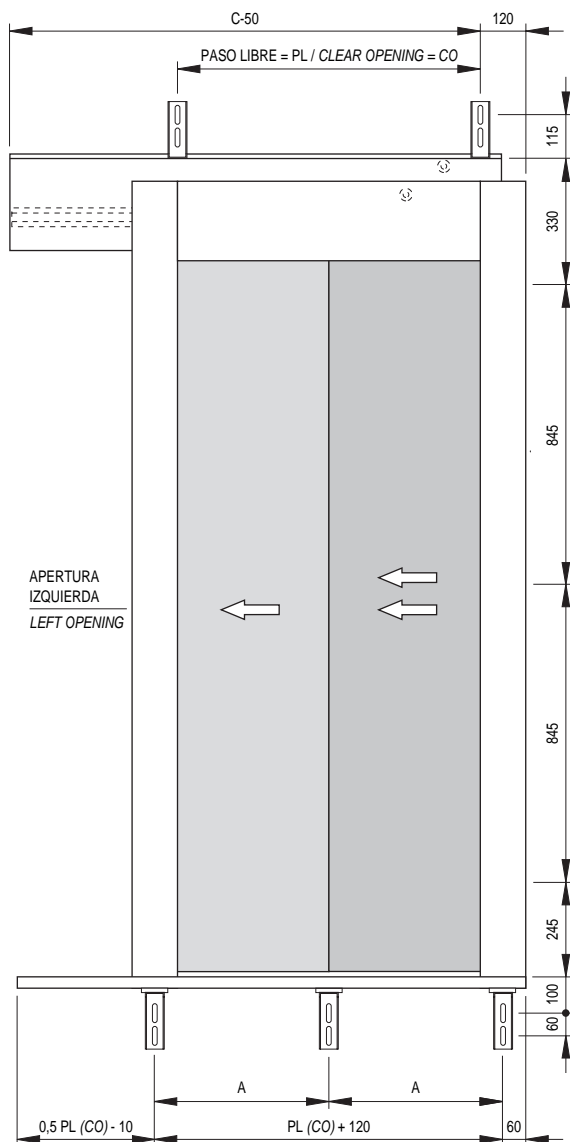

| PL / CO | 600 | 650 | 700 | 750 | 800 | 850 | 900 | 1000 | 1100 | 1200 | 1300 | 1400 | 1500 | 1600 |
|---------|------|------|------|------|------|------|------|------|------|------|------|------|------|------|
| C | 1000 | 1075 | 1150 | 1225 | 1300 | 1375 | 1450 | 1600 | 1750 | 1900 | 2050 | 2200 | 2350 | 2500 |
| A | 360 | 385 | 410 | 435 | 460 | 485 | 340 | 373 | 407 | 330 | 355 | 380 | 324 | 344 |
| S | 3 | 3 | 3 | 3 | 3 | 3 | 4 | 4 | 4 | 5 | 5 | 5 | 6 | 6 |
| T | 5 | 5 | 5 | 5 | 5 | 5 | 6 | 6 | 6 | 8 | 8 | 8 | 9 | 9 |

S: N°. de soportes en apoyo pisadera.
S: Number of supports for sill support.

T: N°. de soportes total.
T: Total number of supports.

6.6.

PUERTA RELLANO TELESCÓPICA 2 HOJAS 2 PANEL SIDE OPENING LANDING DOOR

50/11
DIN 18.091

Fermator
AUTOMATIC DOORS FOR LIFTS

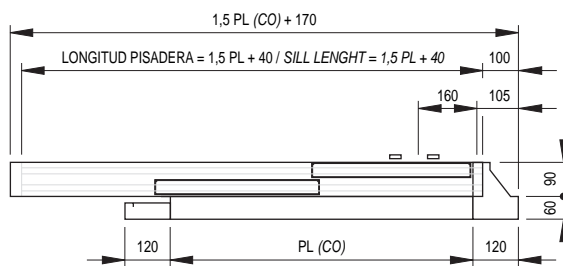
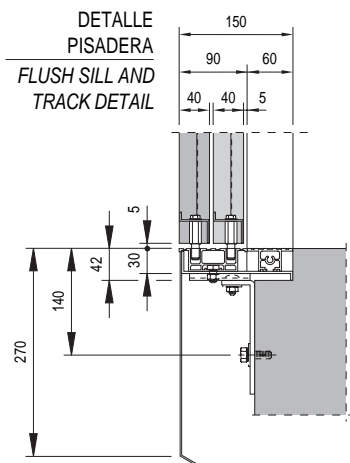
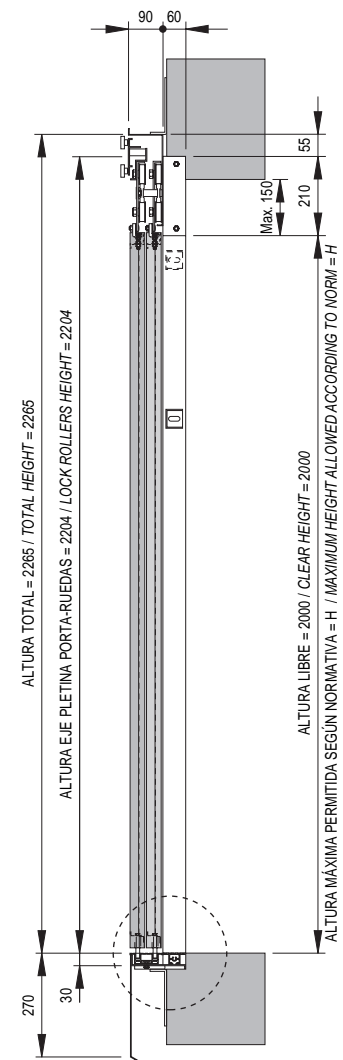
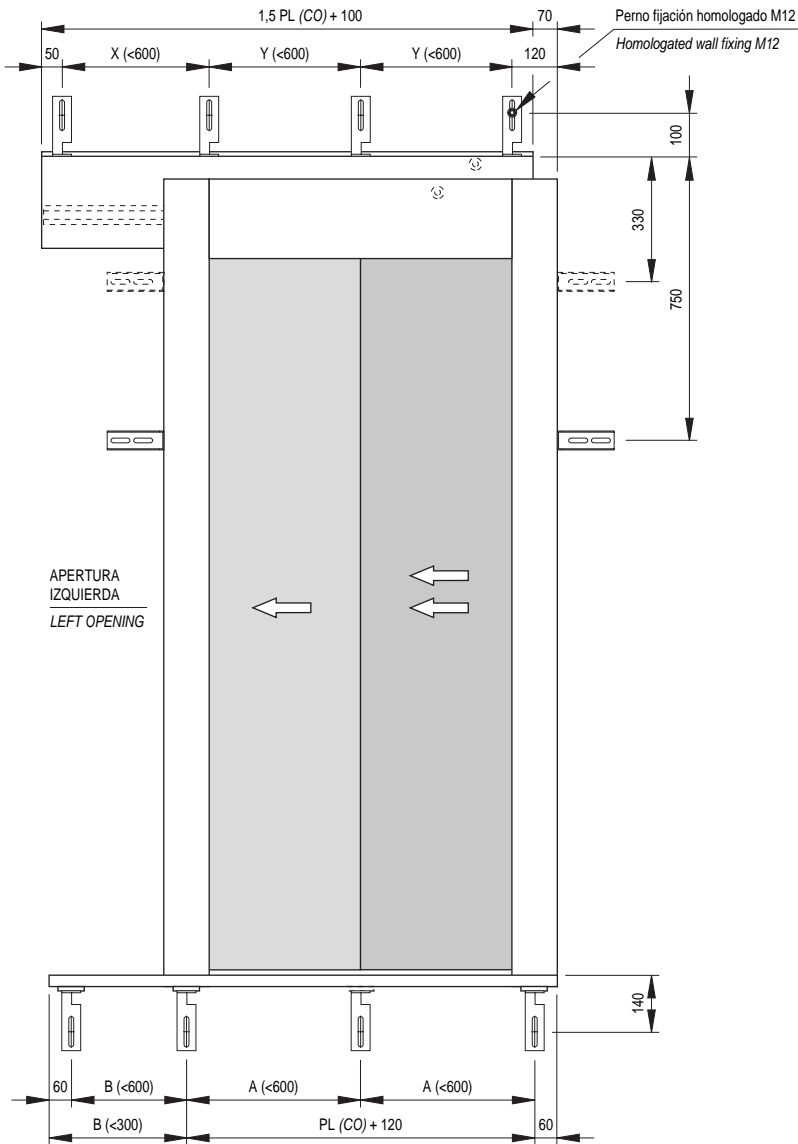

| PL / CO | 600 | 650 | 700 | 750 | 800 | 850 | 900 | 1000 | 1100 | 1200 | 1300 | 1400 | 1500 | 1600 |
|---------|--------|-----|-----|-----|-----|-----|-----|------|------|------|------|------|------|------|
| A | 360 | 385 | 410 | 435 | 460 | 485 | 340 | 373 | 407 | 330 | 355 | 380 | 324 | 344 |
| A' | 280 | 245 | 270 | 295 | 320 | 345 | 370 | 420 | 470 | 520 | 570 | 310 | 335 | 360 |
| X | 300 | 325 | 350 | 375 | 400 | 425 | 450 | 500 | 550 | 600 | 425 | 350 | 375 | 400 |
| Y | 600 | 325 | 350 | 375 | 400 | 425 | 450 | 500 | 550 | 600 | 433 | 467 | 500 | 533 |
| H | ≤ 2500 | | | | | | | | | | | | | |
| R | 3 | 4 | 4 | 4 | 4 | 4 | 4 | 4 | 4 | 4 | 6 | 6 | 6 | 6 |
| S | 3 | 4 | 4 | 4 | 4 | 4 | 5 | 5 | 5 | 6 | 6 | 7 | 8 | 8 |
| T | 8 | 10 | 10 | 10 | 10 | 10 | 11 | 11 | 11 | 12 | 14 | 15 | 16 | 16 |

- Puertas homologadas TÜV (DIN 18091). R: N° de soportes en mecanismo de rellano. S: N° de soportes en apoyo pisadera. T: N° de soportes total.
- Doors certified by TÜV (DIN 18091). R: Number of supports for landing mechanism. S: Number of supports for sill support. T: Total number of supports.

Puerta rellano telescópica 2 hojas modelo 40/10
2 panel side opening landing door model 40/10

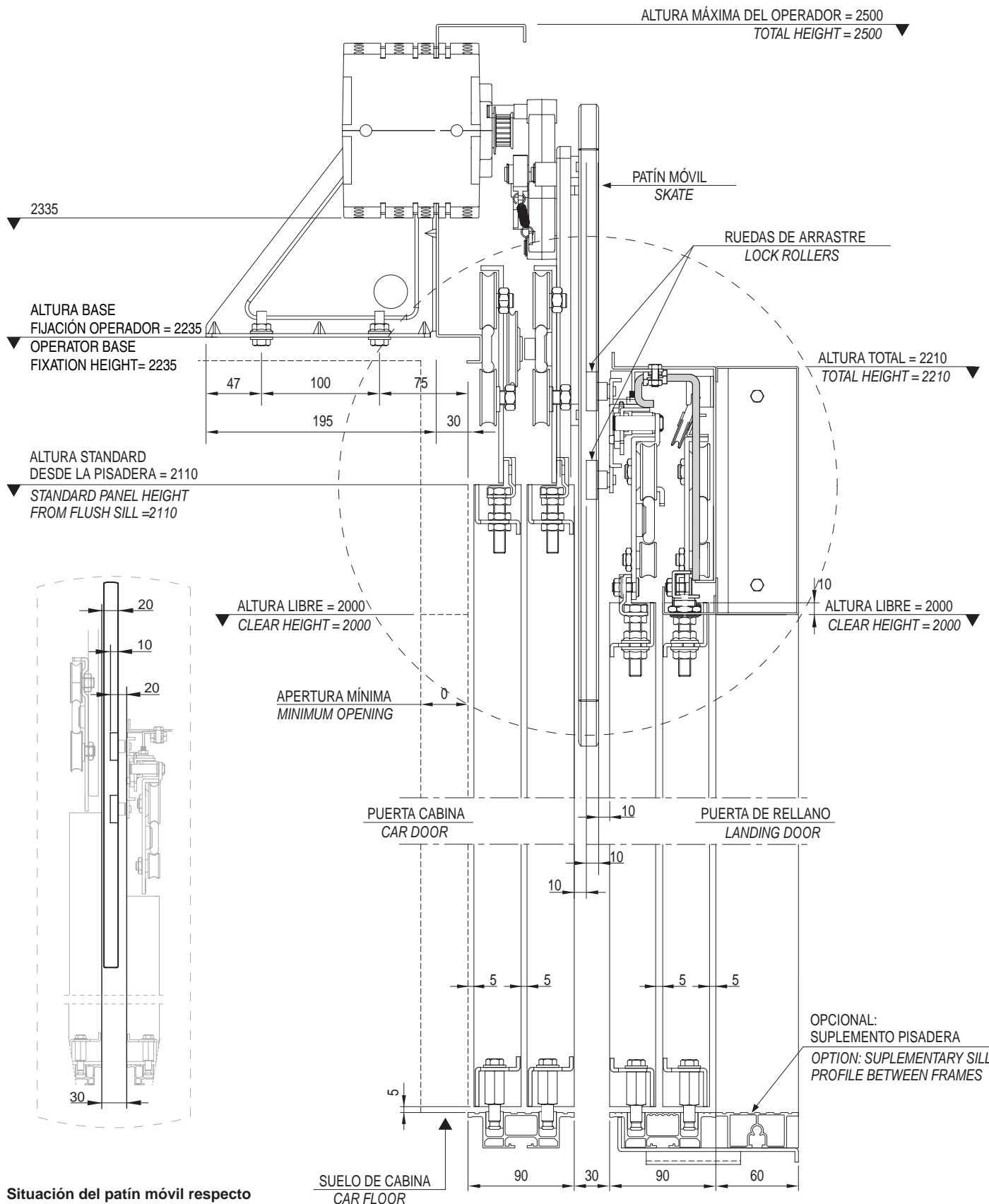

Situación del patín móvil respecto a las ruedas del enclavamiento.

Skate situation in relation to the locking device rollers.

6.8.

SITUACIÓN DEL PATÍN CON LAS RUEDAS DE ARRASTRE COUPLING ARRANGEMENT BETWEEN SKATE AND LOCK

fermator
AUTOMATIC DOORS FOR LIFTS

Puerta rellano telescópica 2 hojas modelo 50/11
2 panel side opening landing door model 50/11

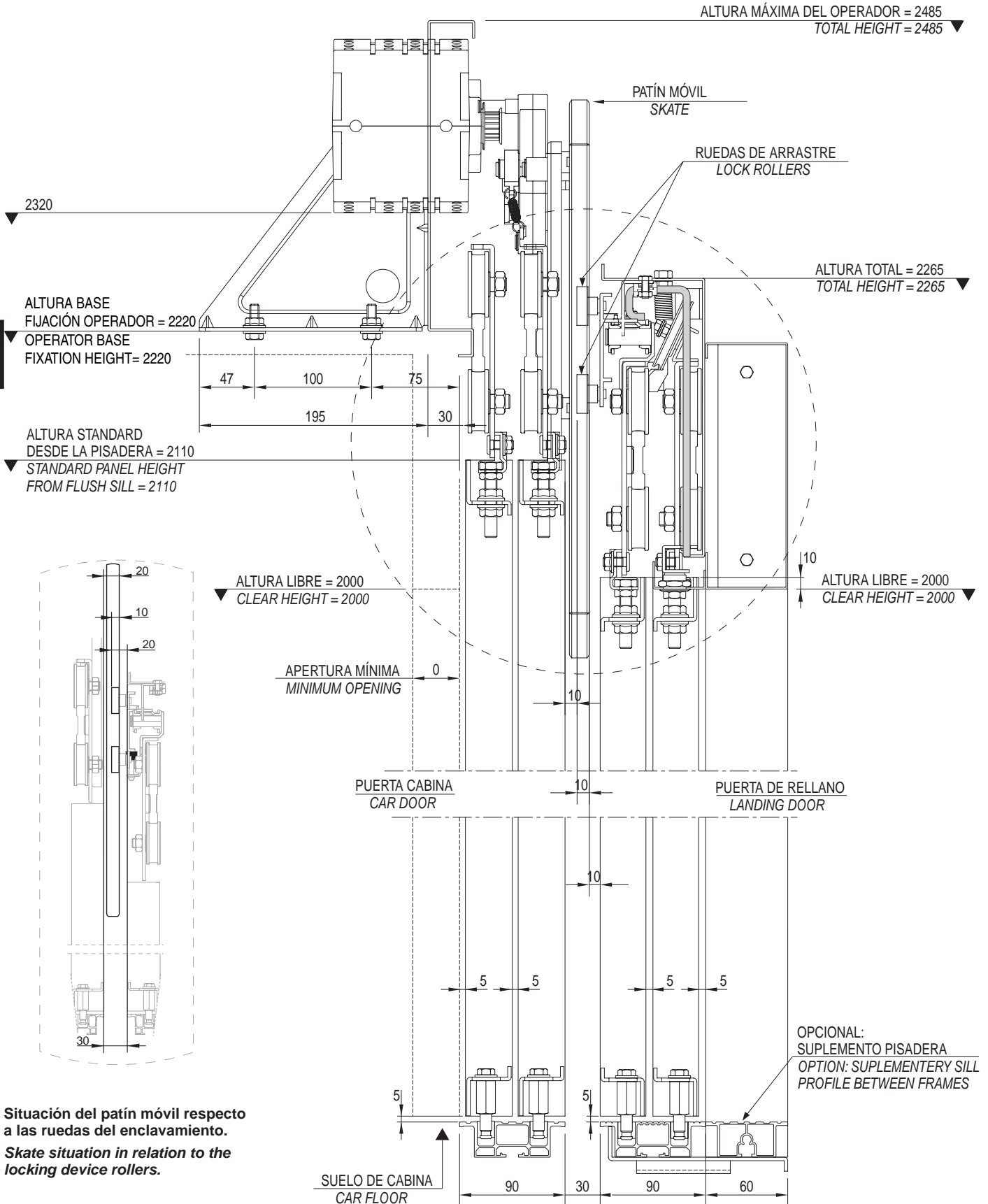

Situación del patín móvil respecto a las ruedas del enclavamiento.
Skate situation in relation to the locking device rollers.

6

Puerta rellano telescópica 2 hojas modelo 40/10 (pisadera 70mm)
2 panel side opening landing door model 40/10 (sill 70mm)

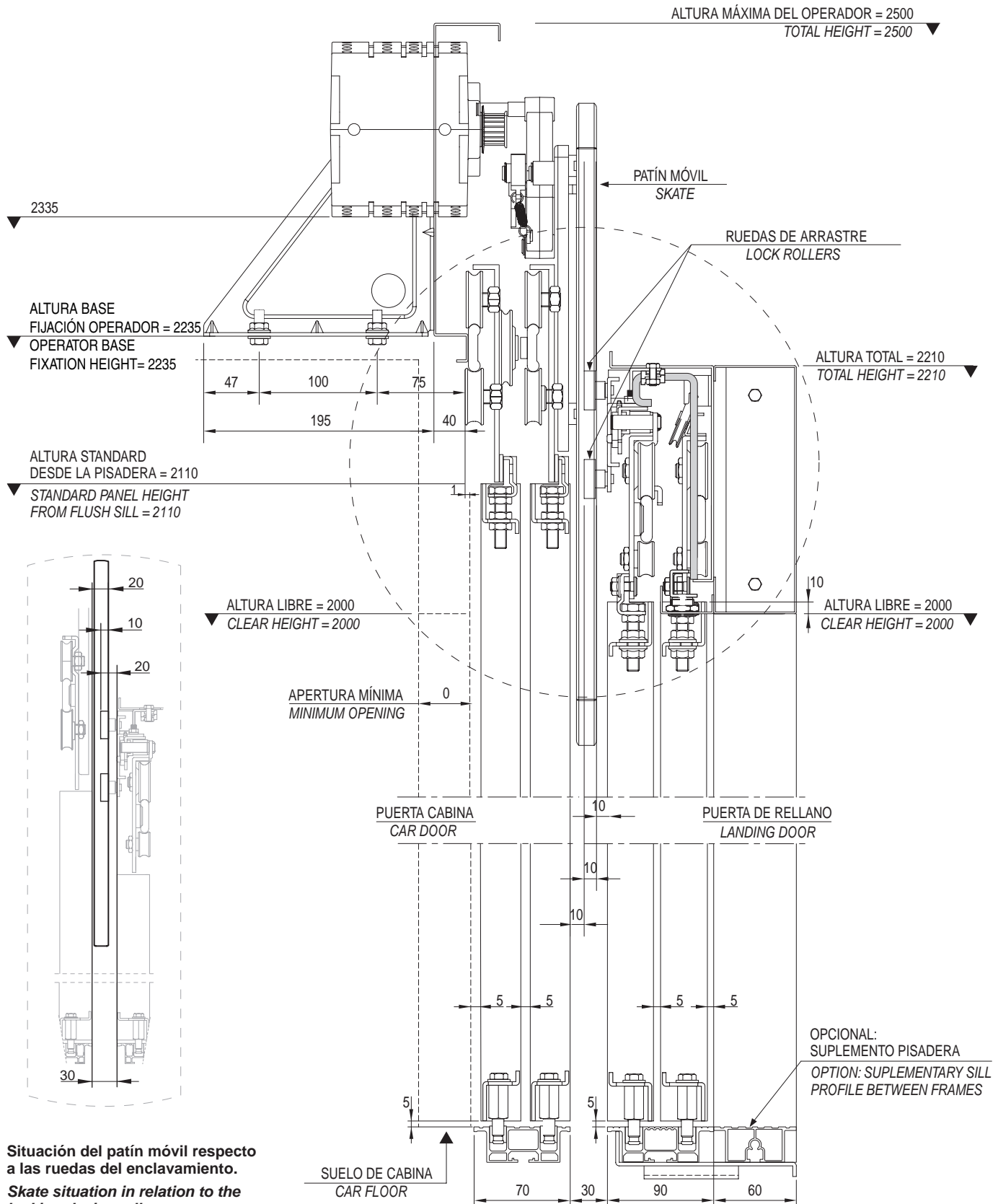

Situación del patín móvil respecto a las ruedas del enclavamiento.
Skate situation in relation to the locking device rollers.

Ferrotec

AUTOMATIC DOORS FOR LIFTS

PUERTA TELESCÓPICA DE 3 HOJAS
3 PANEL SIDE OPENING DOOR

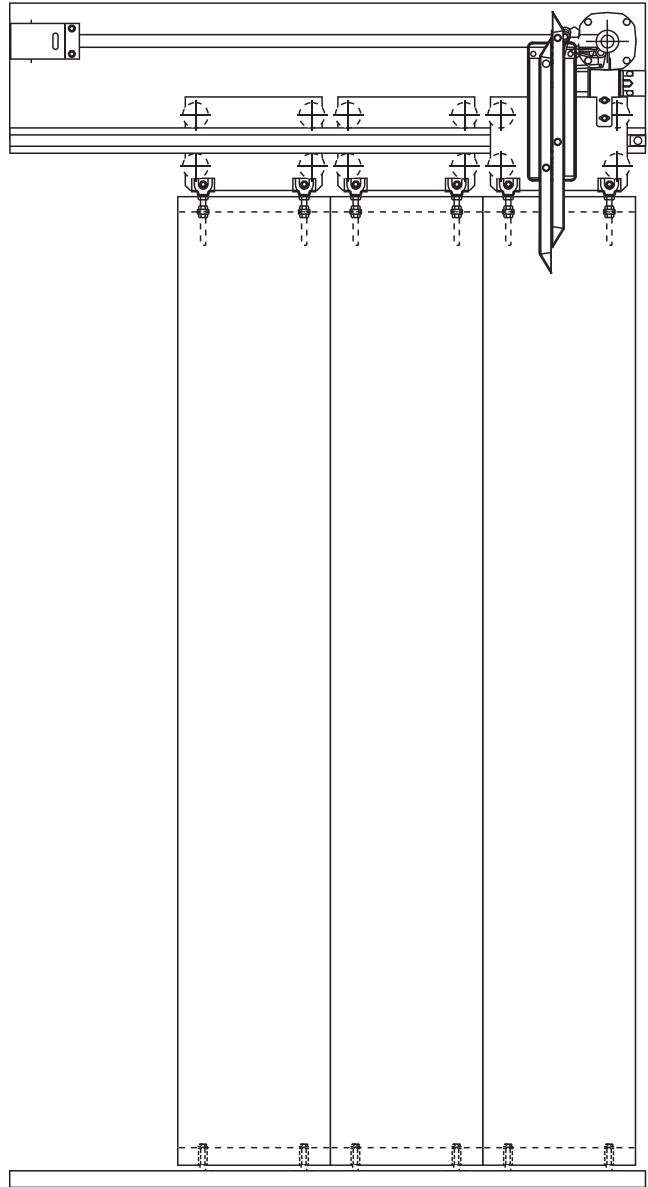

A partir de PL 1400, puerta de cabina con dos motores
From a CO 1400, cabin door with two motors

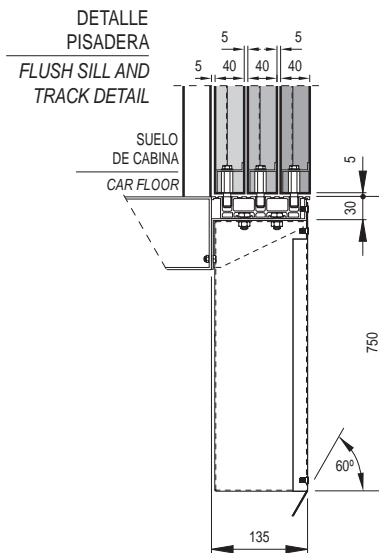
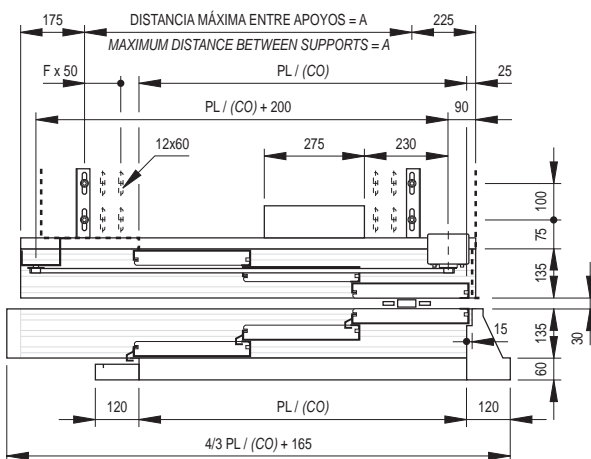
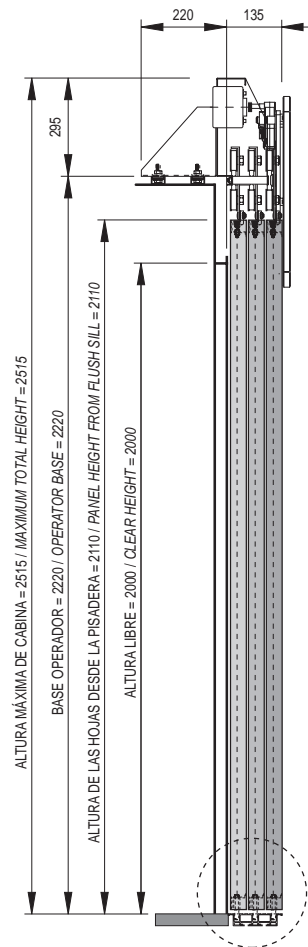
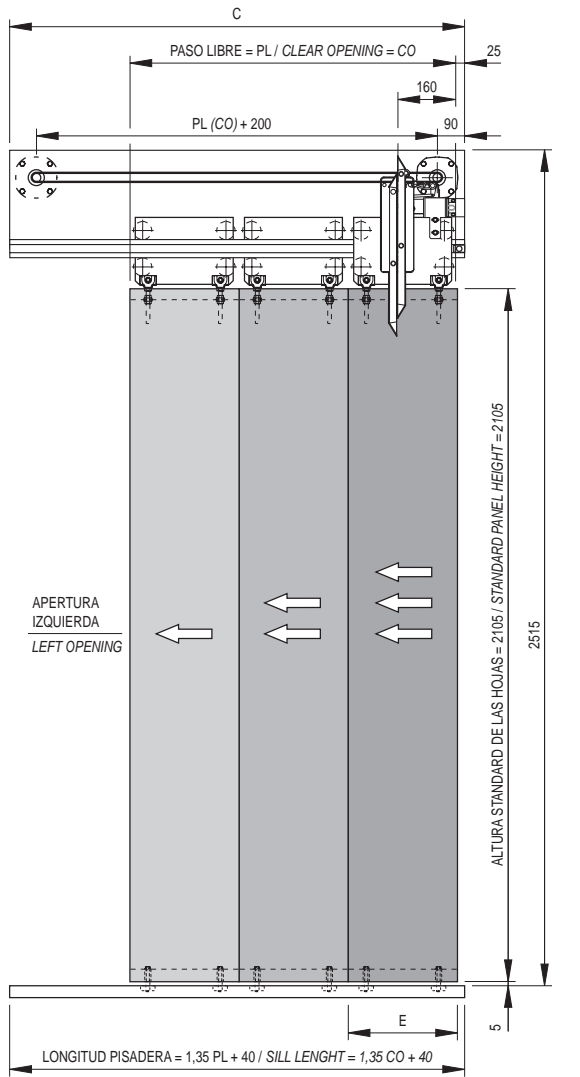

| PL / CO | Un Motor / One Motor | | | | | | | | | | | Dos Motores / Two Motors | | | | | | | |
|--------------------|----------------------|------|------|------|------|------|------|------|------|-------|------|--------------------------|------|------|-------|------|-------|------|--|
| | 600 | 650 | 700 | 750 | 800 | 850 | 900 | 1000 | 1100 | 1200 | 1300 | 1400 | 1500 | 1600 | 1700 | 1800 | 1900 | 2000 | |
| A | 495 | 545 | 595 | 645 | 720 | 795 | 845 | 995 | 1145 | 1295 | 1395 | 1545 | 1695 | 1795 | 1945 | 2045 | 2195 | 2345 | |
| C | 895 | 945 | 995 | 1045 | 1120 | 1195 | 1245 | 1395 | 1545 | 1695 | 1795 | 1945 | 2095 | 2195 | 2345 | 2445 | 2595 | 2745 | |
| E | 220 | 235 | 253 | 270 | 285 | 305 | 320 | 352 | 385 | 420 | 453 | 485 | 520 | 553 | 585 | 620 | 653 | 685 | |
| F | 4 | 4 | 4 | 4 | 4 | 4 | 4 | 4 | 4 | 5 | 5 | 6 | 6 | 6 | 6 | 6 | 6 | 6 | |
| TIEMPO / TIME (s) | 1,56 | 1,62 | 1,68 | 1,74 | 1,8 | 1,85 | 1,91 | 2,01 | 2,11 | 2,2 | 2,3 | 2,4 | 2,5 | 2,6 | 2,7 | 2,8 | 2,9 | 3 | |
| PESO / WEIGHT (kg) | 57 | 61,5 | 66 | 71 | 75,5 | 80,5 | 85 | 94,5 | 104 | 113,5 | 123 | 132,5 | 142 | 151 | 160,5 | 170 | 179,5 | 189 | |

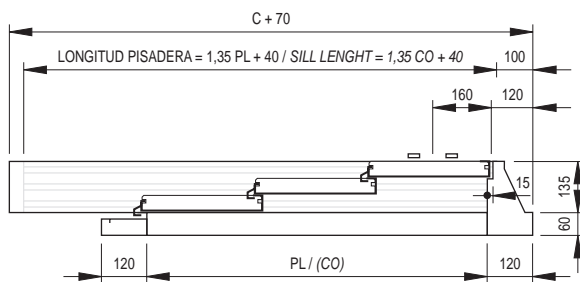
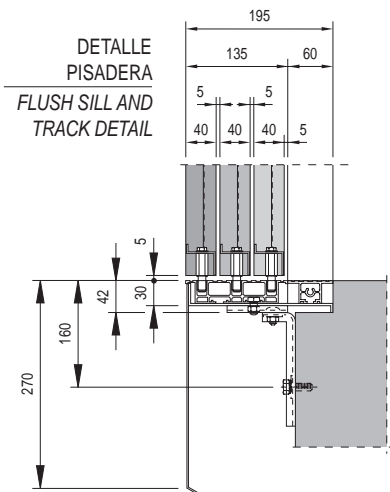
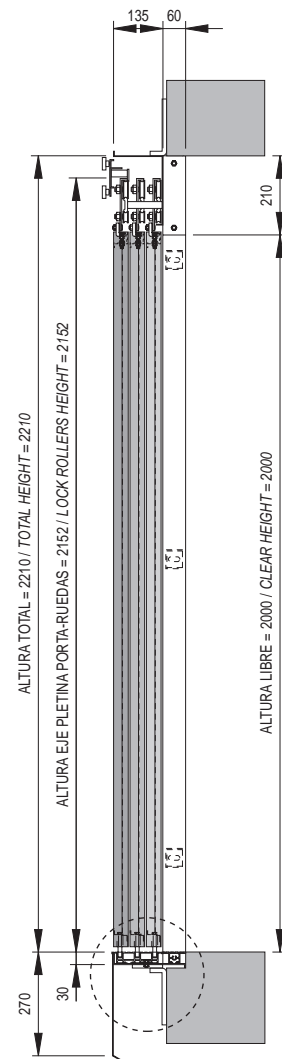
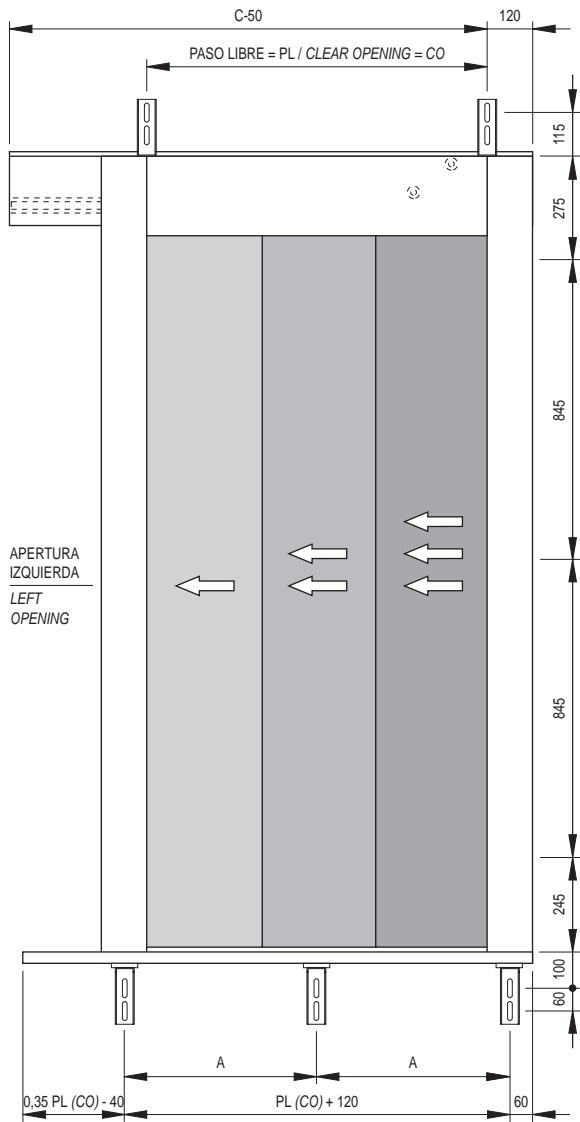

| PL / CO | 600 | 650 | 700 | 750 | 800 | 850 | 900 | 1000 | 1100 | 1200 | 1300 | 1400 |
|---------|-----|-----|------|------|------|------|------|------|------|------|------|------|
| A | 360 | 385 | 410 | 435 | 460 | 485 | 340 | 373 | 407 | 330 | 355 | 380 |
| C | 895 | 962 | 1030 | 1095 | 1160 | 1227 | 1295 | 1430 | 1560 | 1695 | 1830 | 1960 |
| S | 3 | 3 | 3 | 3 | 3 | 3 | 4 | 4 | 4 | 5 | 5 | 5 |
| T | 5 | 5 | 5 | 5 | 5 | 5 | 6 | 6 | 6 | 7 | 7 | 7 |

S: N°. de soportes en apoyo pisadera.
S: Number of supports for sill support.

T: N°. de soportes total.
T: Total number of supports.

Puerta con frontis
Door with infill panels

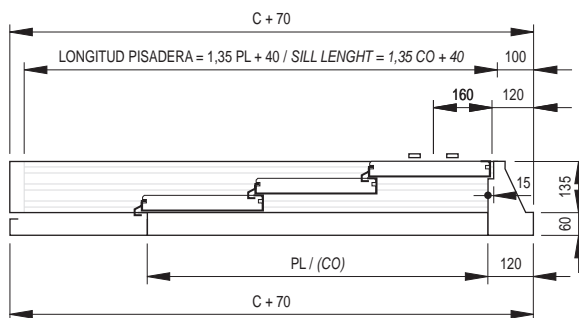
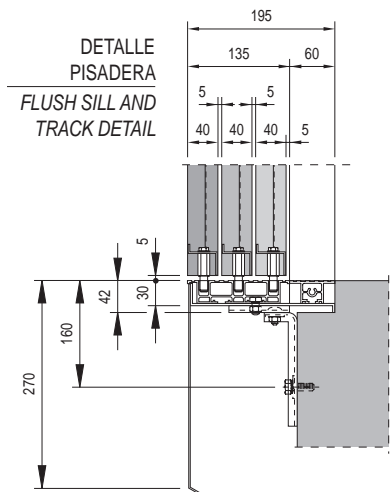
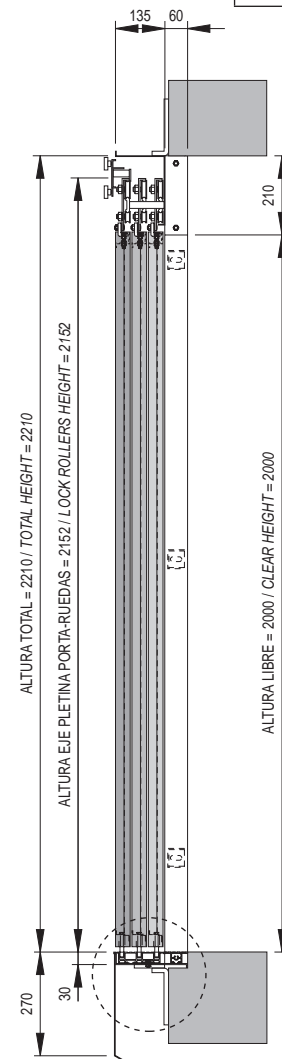
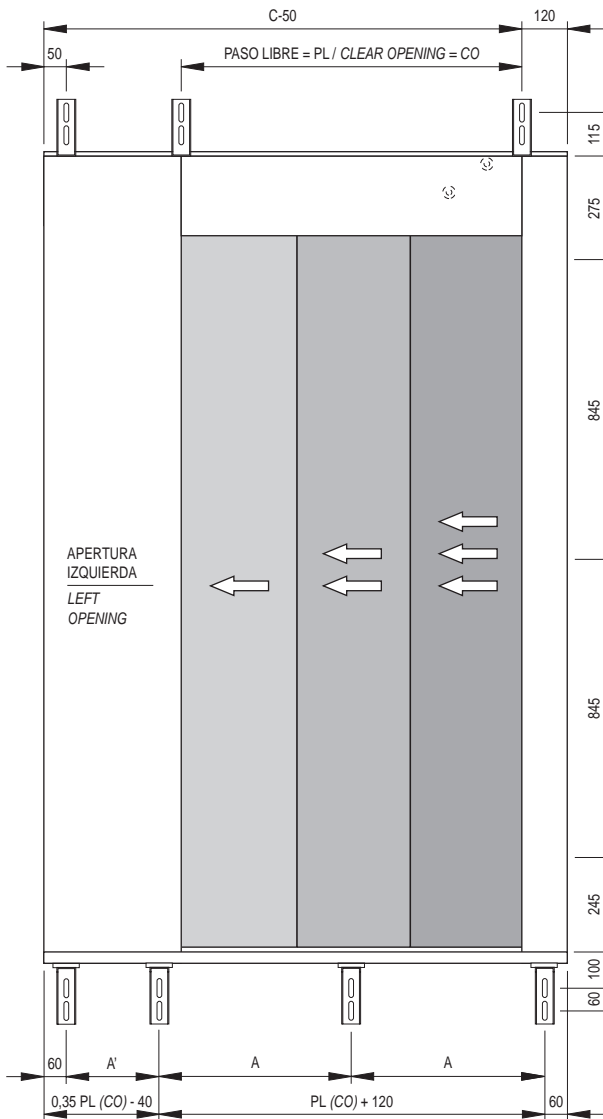

| PL / CO | 600 | 650 | 700 | 750 | 800 | 850 | 900 | 1000 | 1100 | 1200 | 1300 | 1400 |
|---------|-----|-----|------|------|------|------|------|------|------|------|------|------|
| A | 297 | 315 | 330 | 347 | 365 | 380 | 265 | 287 | 310 | 249 | 365 | 380 |
| A' | 125 | 140 | 160 | 175 | 190 | 210 | 225 | 260 | 290 | 325 | 360 | 320 |
| C | 895 | 962 | 1030 | 1095 | 1160 | 1227 | 1295 | 1430 | 1560 | 1695 | 1830 | 1960 |
| S | 4 | 4 | 4 | 4 | 4 | 4 | 5 | 5 | 5 | 6 | 6 | 6 |
| T | 7 | 7 | 7 | 7 | 7 | 7 | 8 | 8 | 8 | 10 | 10 | 10 |

S: N°. de soportes en apoyo pisadera.
S: Number of supports for sill support.

T: N°. de soportes total.
T: Total number of supports.

7.4.

PUERTA RELLANO TELESCÓPICA 3 HOJAS 3 PANEL SIDE OPENING LANDING DOOR

40/10
DIN 18.091

Fermator
AUTOMATIC DOORS FOR LIFTS

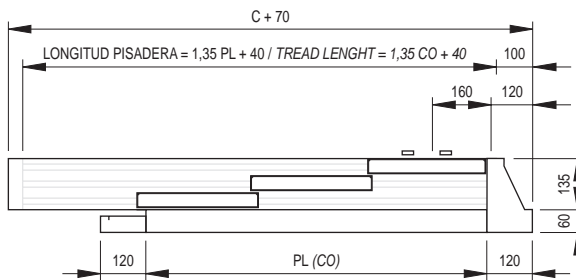
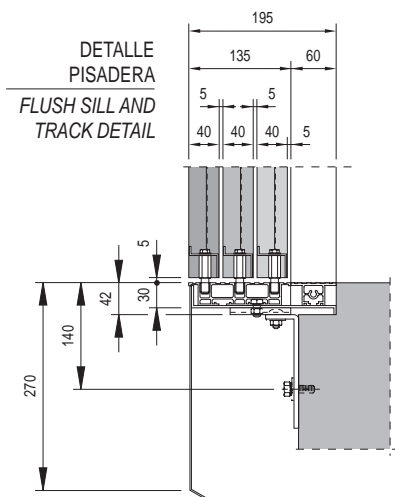
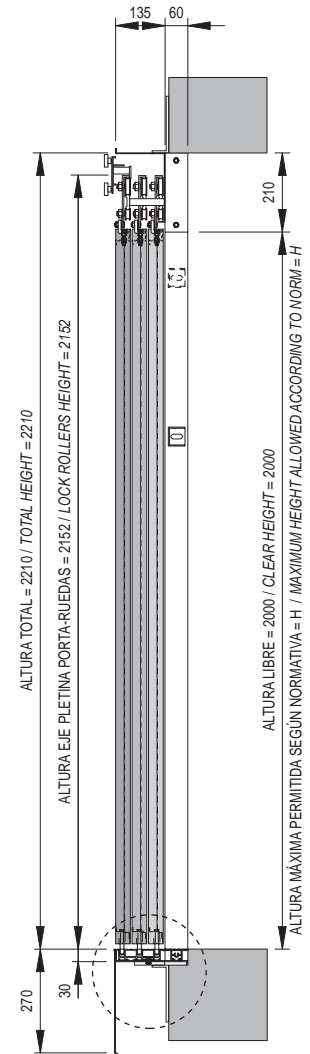
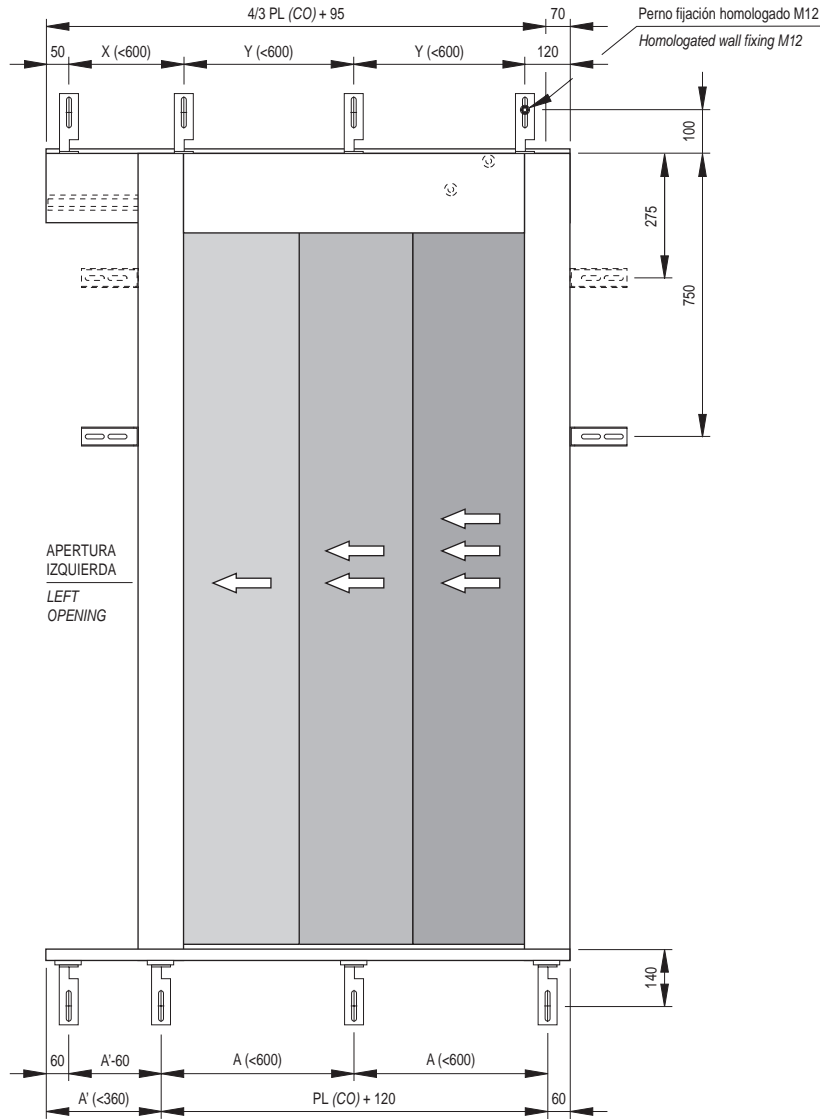

| PL / CO | 600 | 650 | 700 | 750 | 800 | 850 | 900 | 1000 | 1100 | 1200 | 1300 | 1400 |
|---------|-------------|-----|-----|-----|-----|-----|-----|------|------|------|------|------|
| A | 360 | 385 | 410 | 435 | 460 | 485 | 340 | 373 | 407 | 330 | 355 | 380 |
| A' | 175 | 192 | 210 | 225 | 240 | 257 | 275 | 250 | 280 | 315 | 350 | 390 |
| X | 245 | 262 | 280 | 295 | 260 | 275 | 295 | 330 | 360 | 395 | 430 | 460 |
| Y | 600 | 325 | 350 | 375 | 400 | 425 | 450 | 500 | 550 | 600 | 433 | 466 |
| H | ≤ 2500 | | | | | | | | | | | |
| R | 2 | 3 | 3 | 3 | 4 | 4 | 4 | 4 | 4 | 4 | 5 | 5 |
| S | 3 | 3 | 3 | 3 | 3 | 3 | 4 | 5 | 5 | 6 | 6 | 6 |
| T | 7 | 8 | 8 | 8 | 9 | 9 | 10 | 11 | 11 | 12 | 13 | 13 |

☐ Puertas homologadas TÜV (DIN 18091).

R: N.º. de soportes en mecanismo de rellano.

S: N.º. de soportes en apoyo pisadera.

T: N.º. de soportes total.

☐ Doors certified by TÜV (DIN 18091).

R: Number of supports for landing mechanism.

S: Number of supports for sill support.

T: Total number of supports.

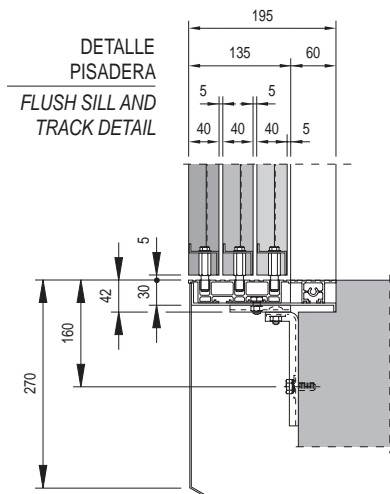
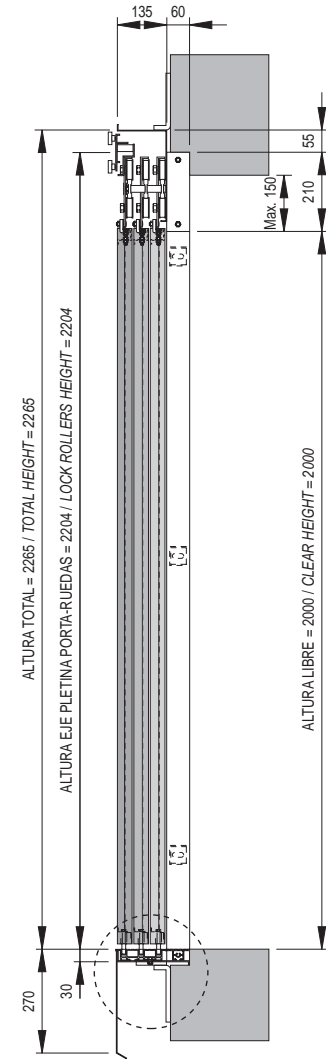
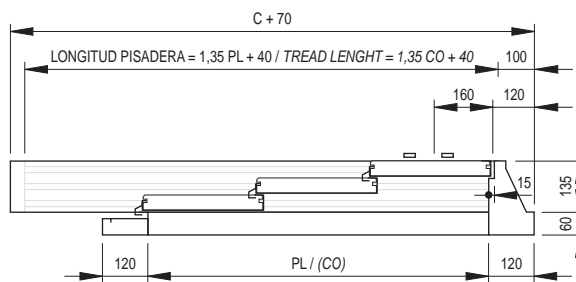
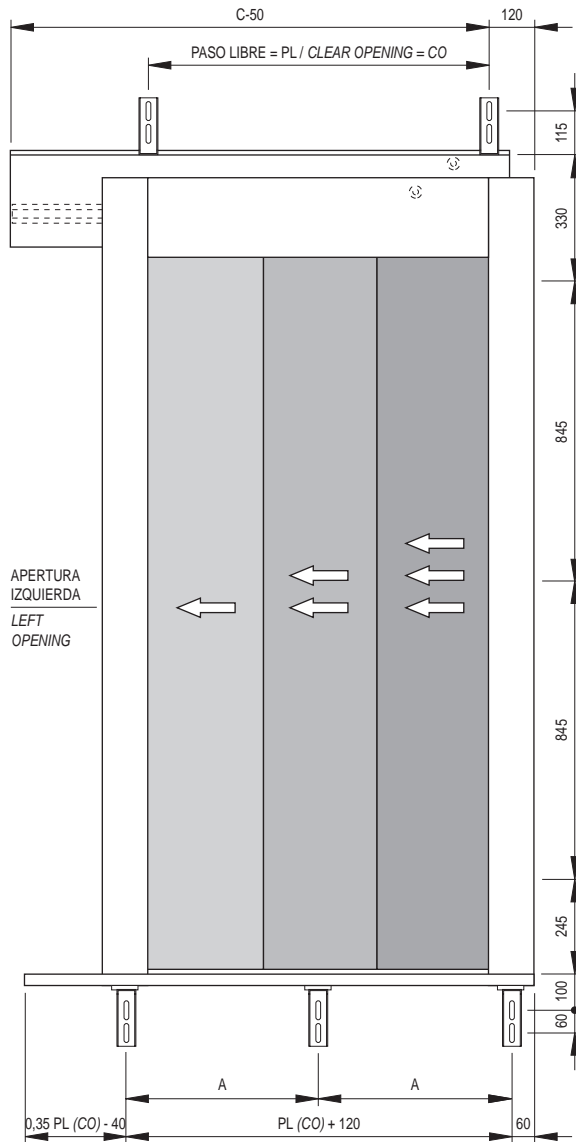

| PL / CO | 600 | 650 | 700 | 750 | 800 | 850 | 900 | 1000 | 1100 | 1200 | 1300 | 1400 | 1500 | 1600 | 1700 | 1800 | 1900 | 2000 |
|---------|-----|-----|------|------|------|------|------|------|------|------|------|------|------|------|------|------|------|------|
| A | 360 | 385 | 410 | 435 | 460 | 485 | 340 | 373 | 407 | 330 | 355 | 380 | 324 | 344 | 303 | 320 | 337 | 303 |
| C | 895 | 962 | 1030 | 1095 | 1160 | 1227 | 1295 | 1430 | 1560 | 1695 | 1830 | 1960 | 2095 | 2230 | 2360 | 2495 | 2630 | 2760 |
| S | 3 | 3 | 3 | 3 | 3 | 3 | 4 | 4 | 4 | 5 | 5 | 5 | 6 | 6 | 7 | 7 | 7 | 8 |
| T | 5 | 5 | 5 | 5 | 5 | 5 | 6 | 6 | 6 | 8 | 8 | 8 | 9 | 9 | 10 | 11 | 11 | 12 |

S: N°. de soportes en apoyo pisadera.
S: Number of supports for sill support.

T: N°. de soportes total.
T: Total number of supports.

7.6.

PUERTA RELANO TELESCÓPICA 3 HOJAS 3 PANEL SIDE OPENING LANDING DOOR

50/11
DIN 18.091

Fermator
AUTOMATIC DOORS FOR LIFTS

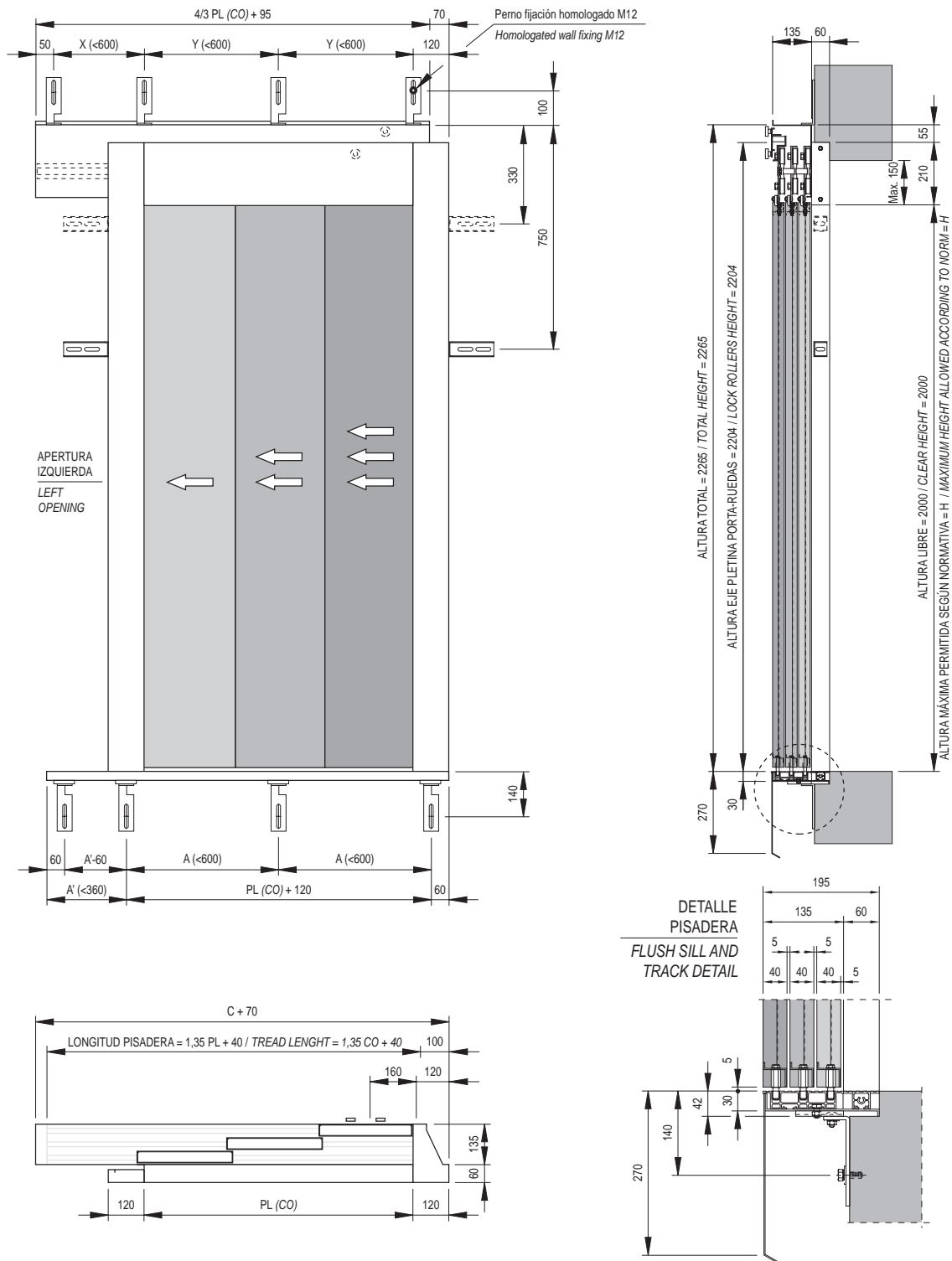

| PL / CO | 600 | 650 | 700 | 750 | 800 | 850 | 900 | 1000 | 1100 | 1200 | 1300 | 1400 | 1500 | 1600 | 1700 | 1800 | 1900 | 2000 | 2100 | 2200 | 2300 | 2400 |
|---------|--------|-----|-----|-----|-----|-----|-----|------|------|------|------|------|------|------|------|------|------|------|------|------|------|------|
| A | 360 | 385 | 410 | 435 | 460 | 485 | 340 | 373 | 407 | 330 | 355 | 380 | 324 | 344 | 364 | 384 | 404 | 353 | 371 | 387 | 403 | 420 |
| A' | 175 | 192 | 210 | 225 | 240 | 257 | 275 | 250 | 280 | 315 | 350 | 380 | 415 | 450 | 480 | 515 | 550 | 580 | 312 | 329 | 345 | 362 |
| X | 245 | 262 | 280 | 295 | 260 | 275 | 295 | 330 | 360 | 395 | 430 | 460 | 495 | 530 | 560 | 595 | 315 | 330 | 347 | 364 | 371 | 397 |
| Y | 600 | 325 | 350 | 375 | 400 | 425 | 450 | 500 | 550 | 600 | 433 | 467 | 500 | 533 | 567 | 600 | 475 | 500 | 525 | 550 | 575 | 600 |
| H | ≤ 2500 | | | | | | | | | | | | | | | | | | | | | |
| R | 2 | 3 | 3 | 3 | 4 | 4 | 4 | 4 | 4 | 4 | 5 | 5 | 5 | 5 | 5 | 5 | 7 | 7 | 7 | 7 | 7 | 7 |
| S | 3 | 3 | 3 | 3 | 3 | 3 | 4 | 5 | 5 | 6 | 6 | 6 | 7 | 7 | 7 | 7 | 7 | 8 | 9 | 9 | 9 | 9 |
| T | 7 | 8 | 8 | 8 | 9 | 9 | 10 | 11 | 11 | 12 | 13 | 13 | 14 | 14 | 14 | 14 | 16 | 17 | 18 | 18 | 18 | 18 |

Puertas homologadas TÜV (DIN 18091). R: N°. de soportes en mecanismo de relano. S: N°. de soportes en apoyo pisadera. T: N°. de soportes total.
 Doors certified by TÜV (DIN 18091). R: Number of supports for landing mechanism. S: Number of supports for sill support. T: Total number of supports.

Puerta rellano telescópica 3 hojas modelo 40/10 (pisadera 135mm)
3 panel side opening landing door model 40/10 (sill 135mm)

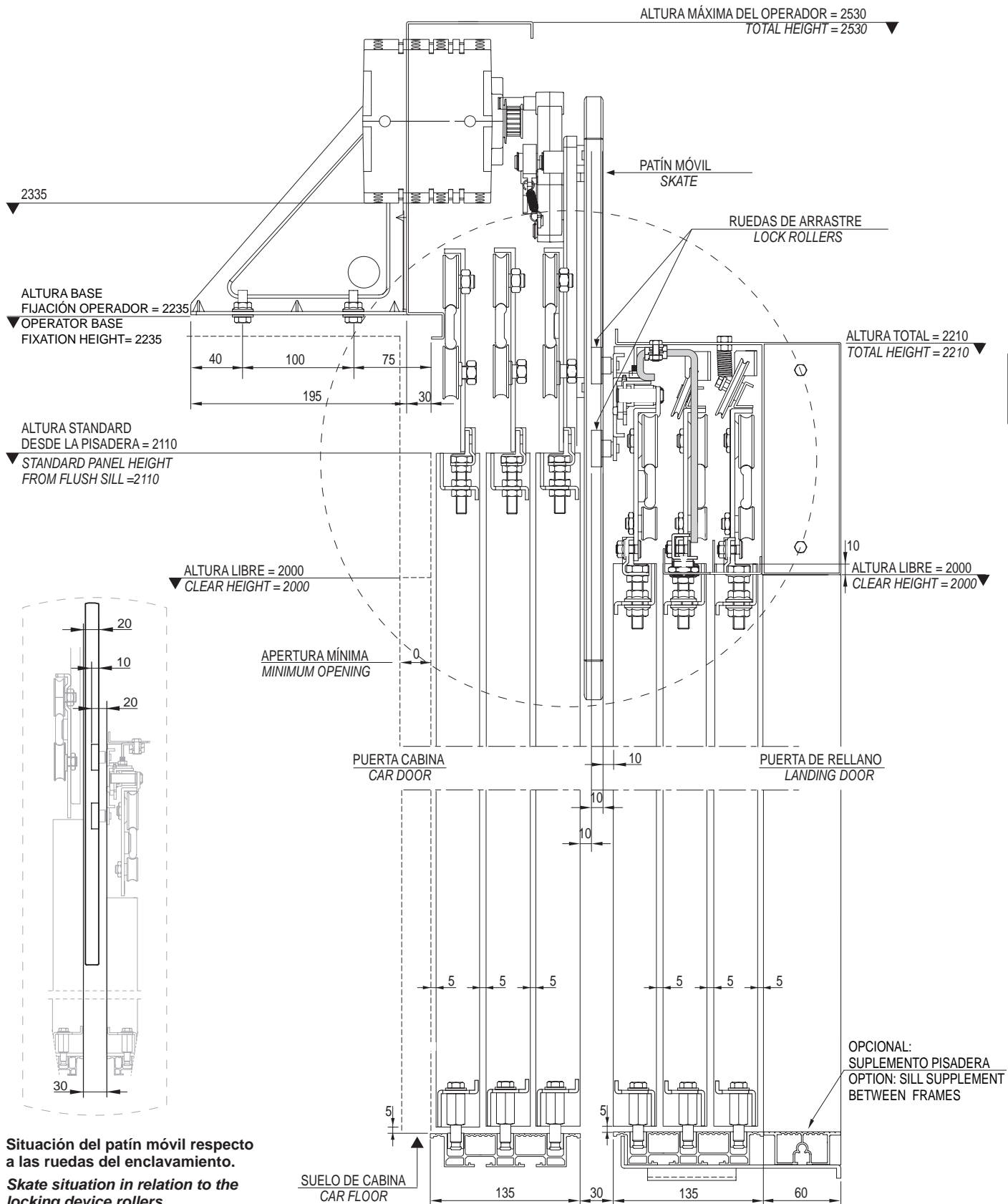

Situación del patín móvil respecto a las ruedas del enclavamiento.
Skate situation in relation to the locking device rollers.

7.8.

SITUACIÓN DEL PATÍN CON LAS RUEDAS DE ARRASTRE COUPLING ARRANGEMENT BETWEEN SKATE AND LOCK

Fermator
AUTOMATIC DOORS FOR LIFTS

Puerta rellano telescópica 3 hojas modelo 50/11 (pisadera 135mm)
3 panel side opening landing door model 50/11 (sill 135mm)

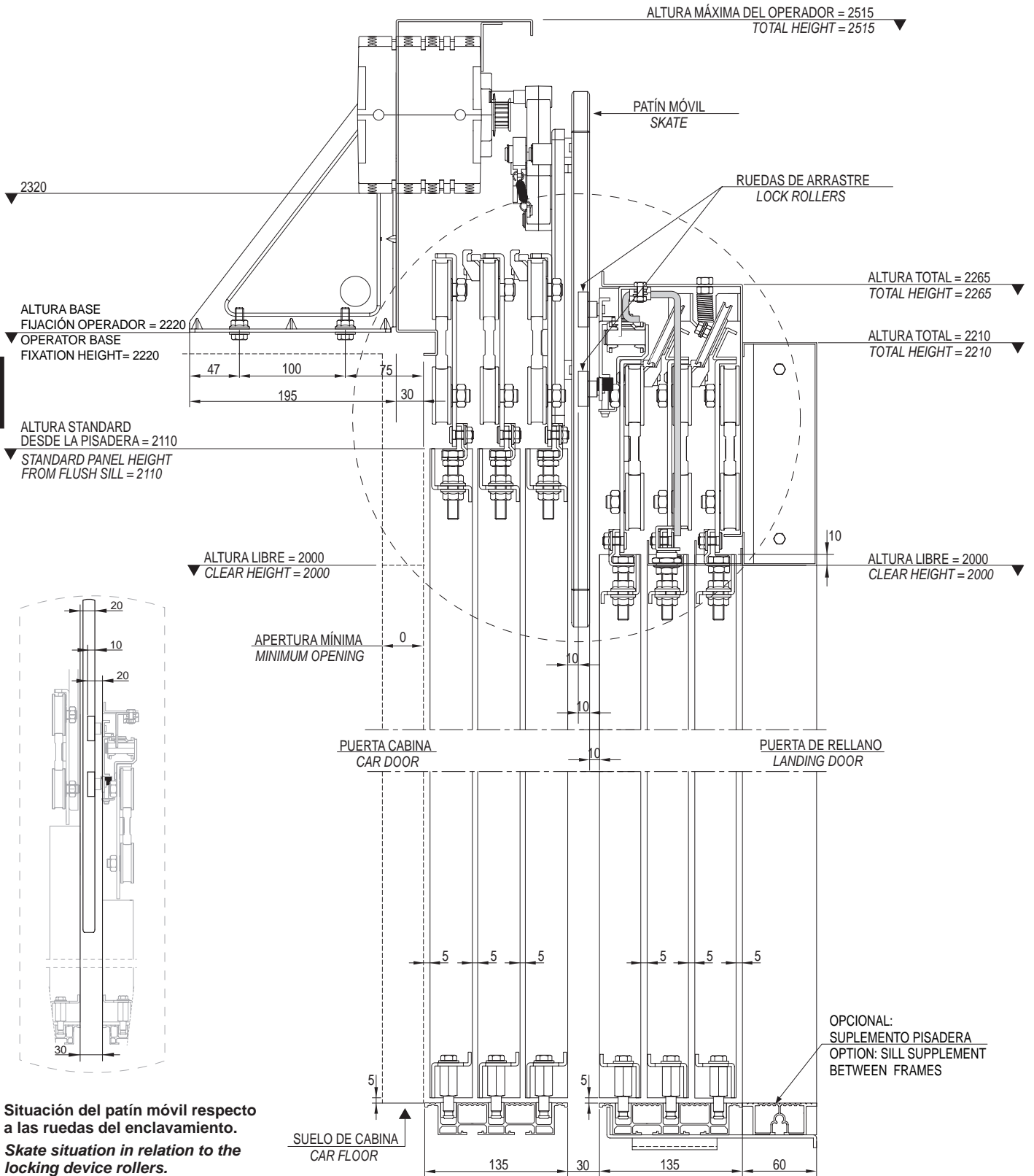

Situación del patín móvil respecto a las ruedas del enclavamiento.
Skate situation in relation to the locking device rollers.

7

Puerta de rellano telescópica 3 hojas modelo 40/10 (pisadera 90mm)
3 panel side opening landing door model 40/10 (sill 90mm)

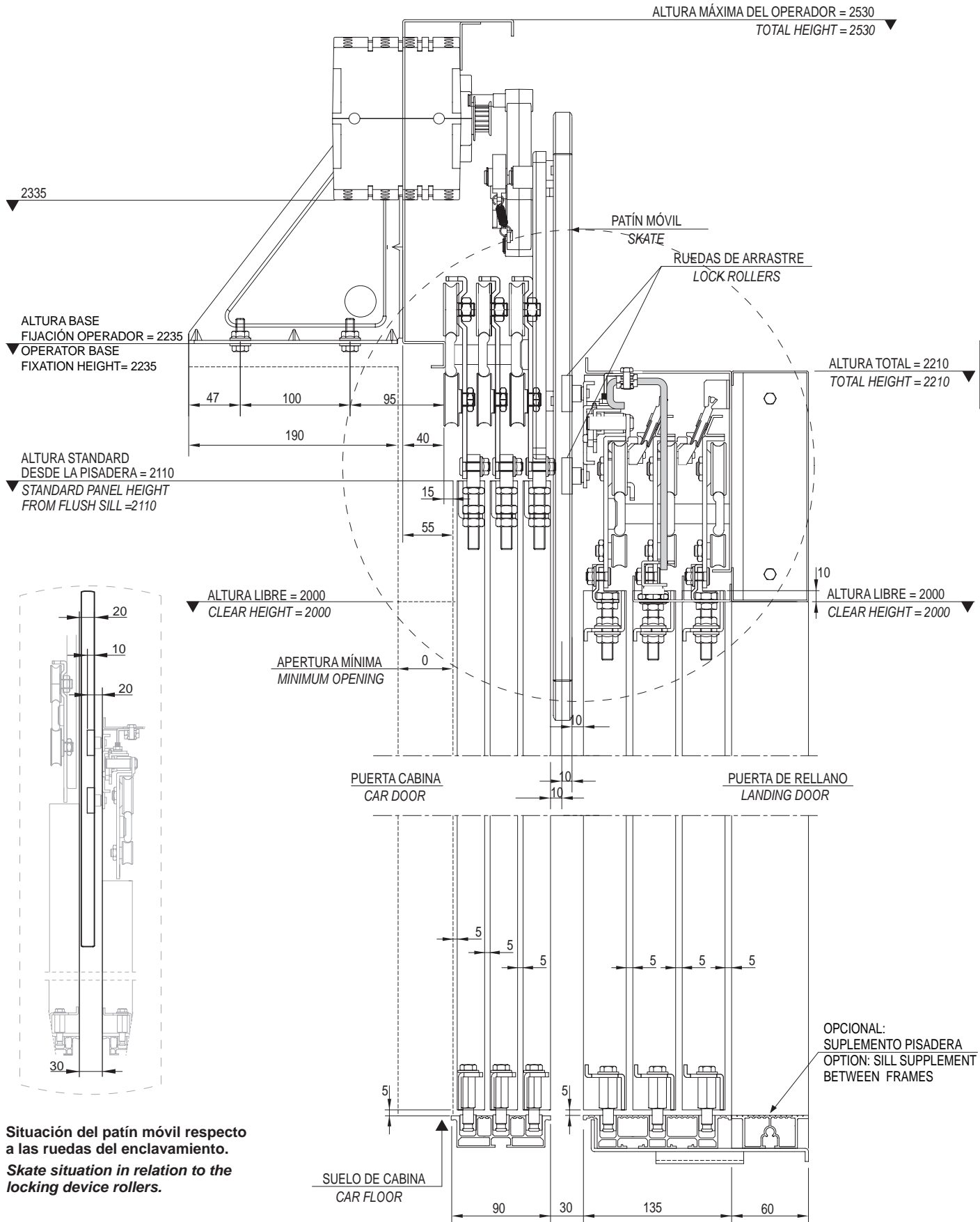

Situación del patín móvil respecto a las ruedas del enclavamiento.
Skate situation in relation to the locking device rollers.

Ferrotec

AUTOMATIC DOORS FOR LIFTS

PUERTA TELESCÓPICA DE 4 HOJAS
4 PANEL SIDE OPENING DOOR

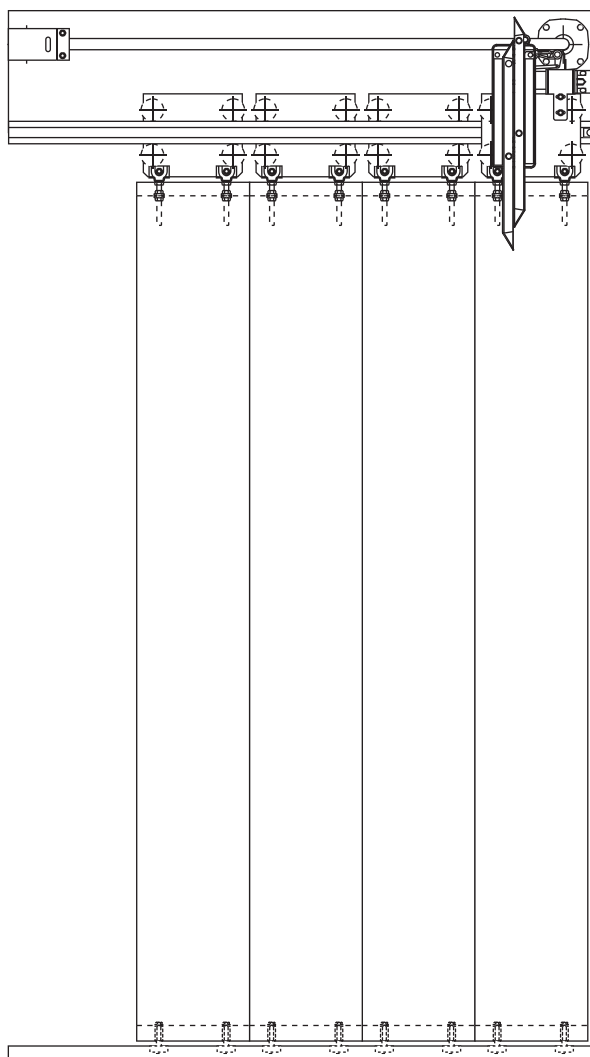

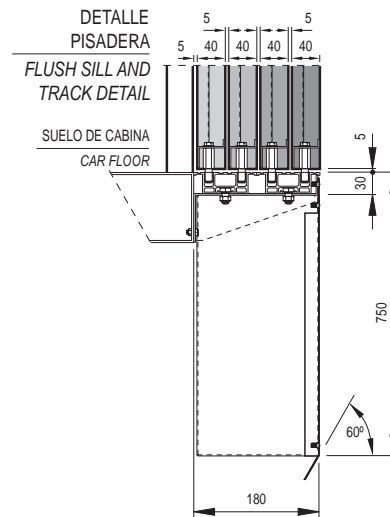
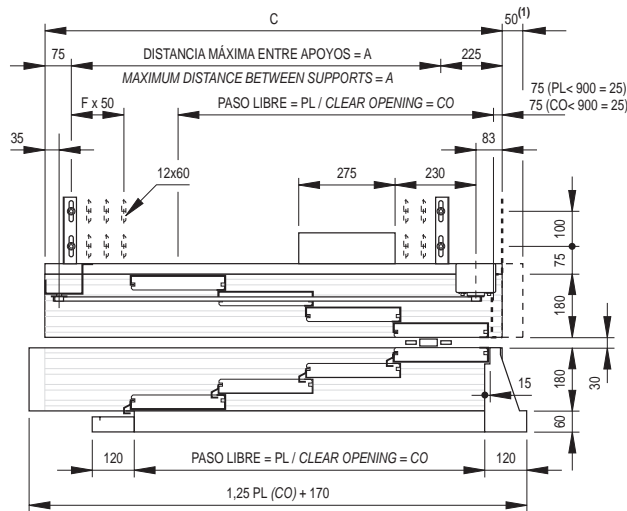
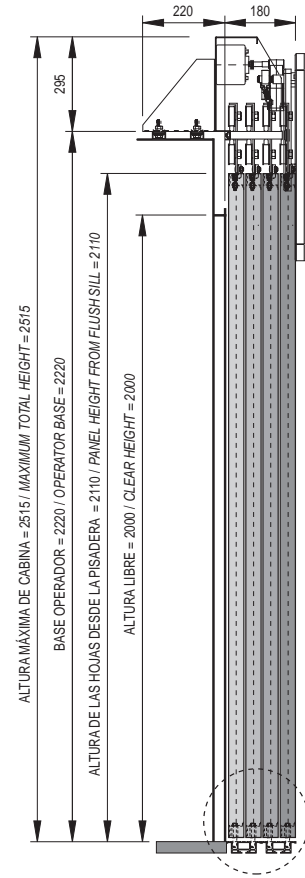
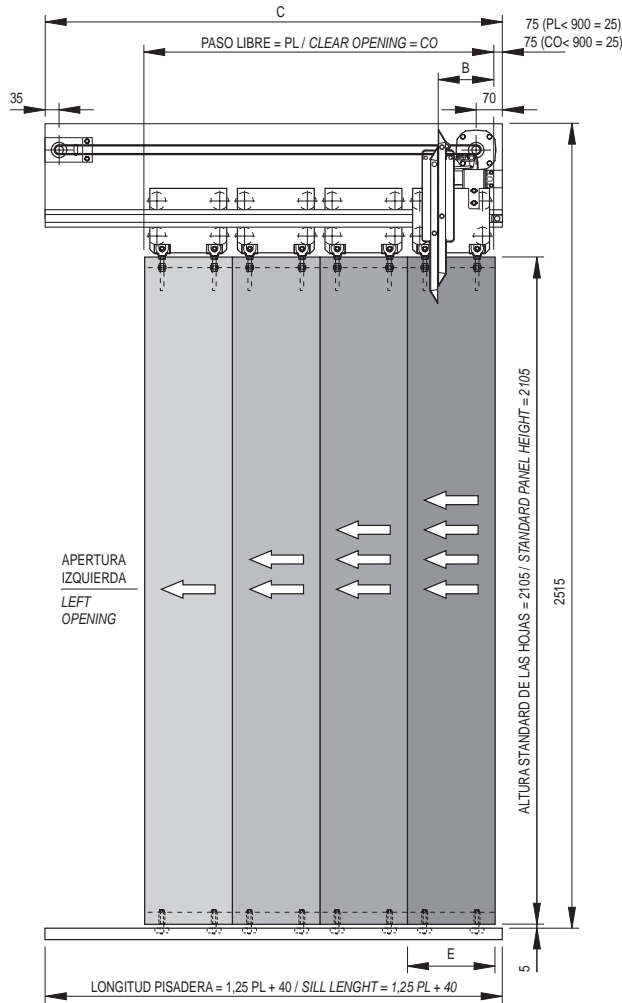

| PL / CO | Un Motor / One Motor | | | | | | | | | | | Dos Motores / Two Motors | | | | | | | |
|--------------------|----------------------|--------------------|--------------------|--------------------|--------------------|--------------------|--------------------|-------|------|------|-------|--------------------------|------|------|-------|-------|------|------|--|
| | 600 ⁽¹⁾ | 650 ⁽¹⁾ | 700 ⁽¹⁾ | 750 ⁽¹⁾ | 800 ⁽¹⁾ | 850 ⁽¹⁾ | 900 ⁽¹⁾ | 1000 | 1100 | 1200 | 1300 | 1400 | 1500 | 1600 | 1700 | 1800 | 1900 | 2000 | |
| A | 505 | 570 | 630 | 695 | 755 | 820 | 880 | 1005 | 1130 | 1255 | 1375 | 1500 | 1625 | 1705 | 1830 | 2055 | 2180 | 2305 | |
| B | 100 | 100 | 100 | 100 | 100 | 100 | 100 | 160 | 160 | 160 | 160 | 160 | 160 | 160 | 160 | 160 | 160 | 160 | |
| C | 850 | 910 | 975 | 1035 | 1100 | 1160 | 1225 | 1300 | 1425 | 1550 | 1675 | 1800 | 1925 | 2050 | 2175 | 2300 | 2425 | 2550 | |
| E | 170 | 182 | 195 | 207 | 220 | 232 | 245 | 270 | 295 | 320 | 345 | 370 | 395 | 420 | 445 | 470 | 495 | 520 | |
| F | 3 | 3 | 4 | 4 | 4 | 4 | 5 | 6 | 7 | 8 | 9 | 9 | 10 | 6 | 6 | 6 | 6 | 6 | |
| TIEMPO / TIME (s) | 1,56 | 1,62 | 1,68 | 1,74 | 1,8 | 1,85 | 1,91 | 2,01 | 2,11 | 2,2 | 2,3 | 2,4 | 2,5 | 2,6 | 2,7 | 2,8 | 2,9 | 3 | |
| PESO / WEIGHT (kg) | 61,5 | 67 | 72 | 77 | 82 | 87,5 | 92,5 | 102,5 | 113 | 123 | 133,5 | 143,5 | 154 | 164 | 174,5 | 184,5 | 195 | 205 | |

(1) Con semiautomática / With semiautomatic : C - 50 mm.

Consultar con nuestro departamento técnico - To be consulted to our technical department.

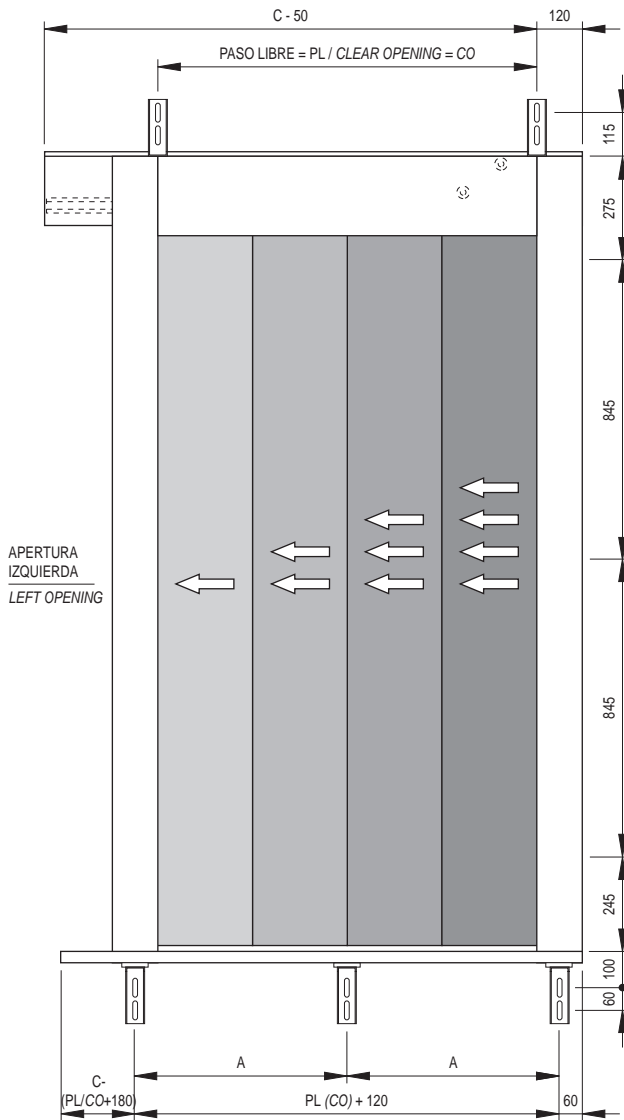

APERTURA
IZQUIERDA
LEFT OPENING

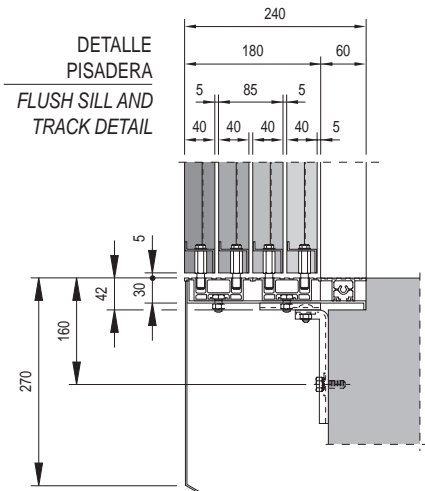
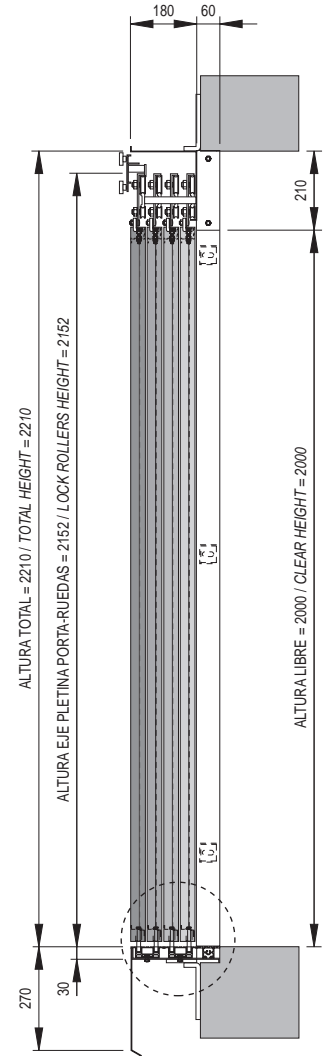
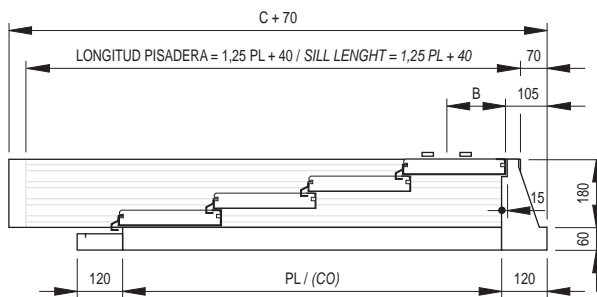

DETALLE
PISADERA
FLUSH SILL AND
TRACK DETAIL

| PL / CO | 600 | 650 | 700 | 750 | 800 | 850 | 900 | 1000 | 1100 | 1200 | 1300 | 1400 |
|---------|-----|-----|-----|------|------|------|------|------|------|------|------|------|
| A | 360 | 385 | 410 | 435 | 460 | 485 | 340 | 373 | 407 | 330 | 355 | 380 |
| B | 100 | 100 | 100 | 100 | 100 | 100 | 100 | 160 | 160 | 160 | 160 | 160 |
| C | 875 | 925 | 975 | 1039 | 1100 | 1164 | 1225 | 1350 | 1475 | 1600 | 1725 | 1850 |
| S | 3 | 3 | 3 | 3 | 3 | 3 | 3 | 3 | 4 | 4 | 4 | 4 |
| T | 5 | 5 | 5 | 5 | 5 | 5 | 5 | 5 | 6 | 7 | 7 | 7 |

S: N° de soportes en apoyo pisadera.
S: Number of supports for sill support.

T: N° de soportes total.
T: Total number of supports.

Puerta con frontis
Door with infill panels

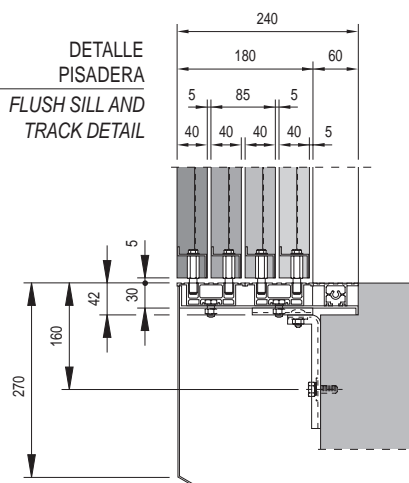
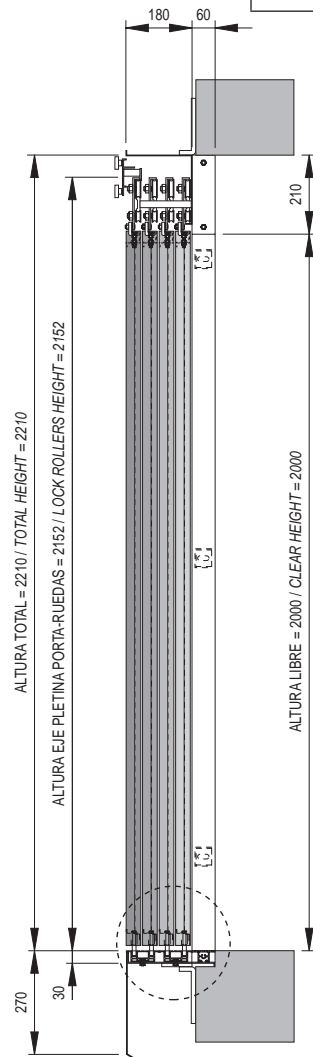
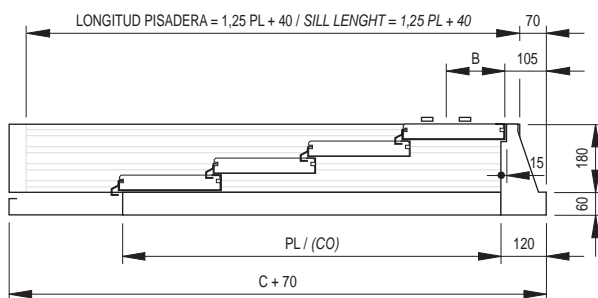
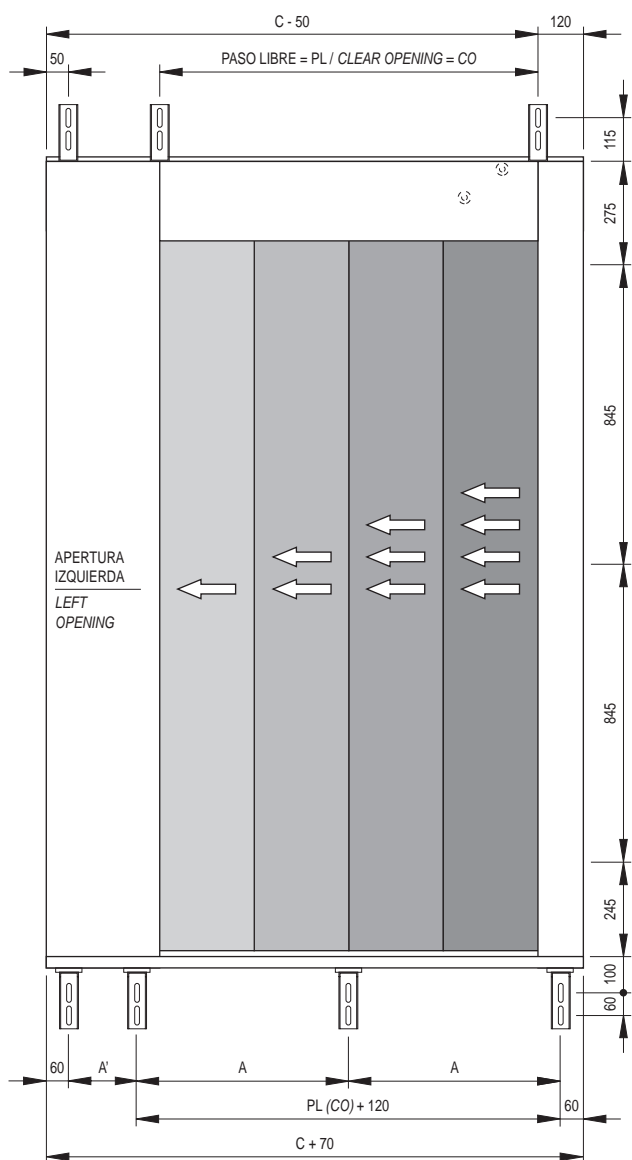

| PL / CO | 600 | 650 | 700 | 750 | 800 | 850 | 900 | 1000 | 1100 | 1200 | 1300 | 1400 |
|---------|-----|-----|-----|------|------|------|------|------|------|------|------|------|
| A | 320 | 339 | 238 | 251 | 263 | 276 | 288 | 235 | 254 | 272 | 291 | 248 |
| A' | 80 | 92 | 105 | 117 | 130 | 142 | 155 | 180 | 205 | 230 | 255 | 280 |
| B | 100 | 100 | 100 | 100 | 100 | 100 | 100 | 160 | 160 | 160 | 160 | 160 |
| C | 875 | 925 | 975 | 1039 | 1100 | 1164 | 1225 | 1350 | 1475 | 1600 | 1725 | 1850 |
| S | 3 | 3 | 4 | 4 | 4 | 4 | 4 | 5 | 5 | 5 | 5 | 6 |
| T | 6 | 6 | 7 | 7 | 7 | 7 | 7 | 8 | 8 | 9 | 9 | 10 |

S: N°. de soportes en apoyo pisadera.
S: Number of supports for sill support.

T: N°. de soportes total.
T: Total number of supports.

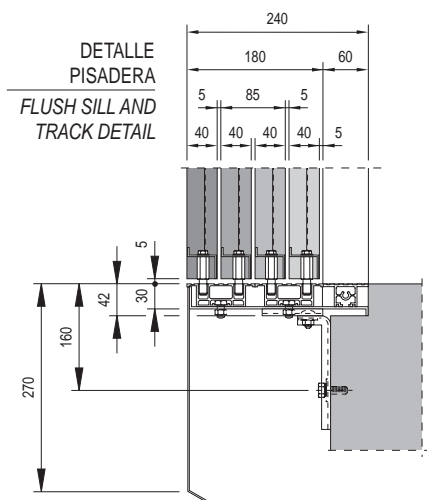
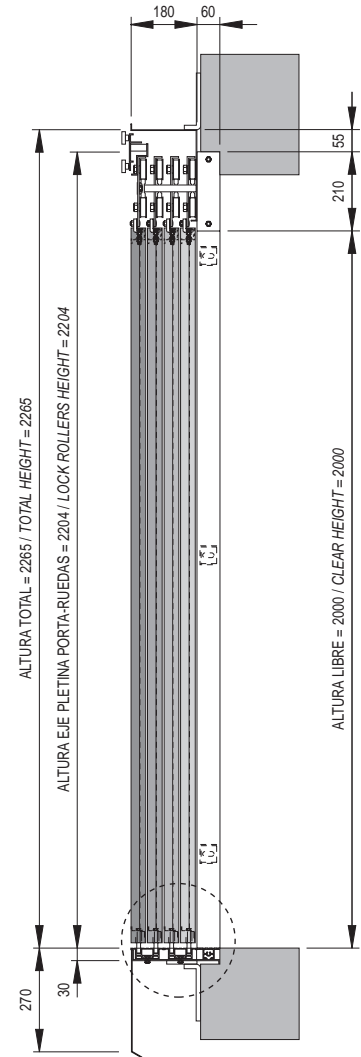
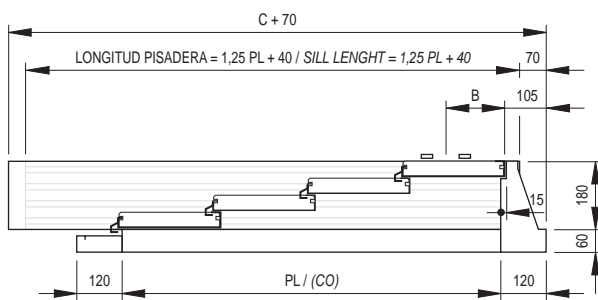
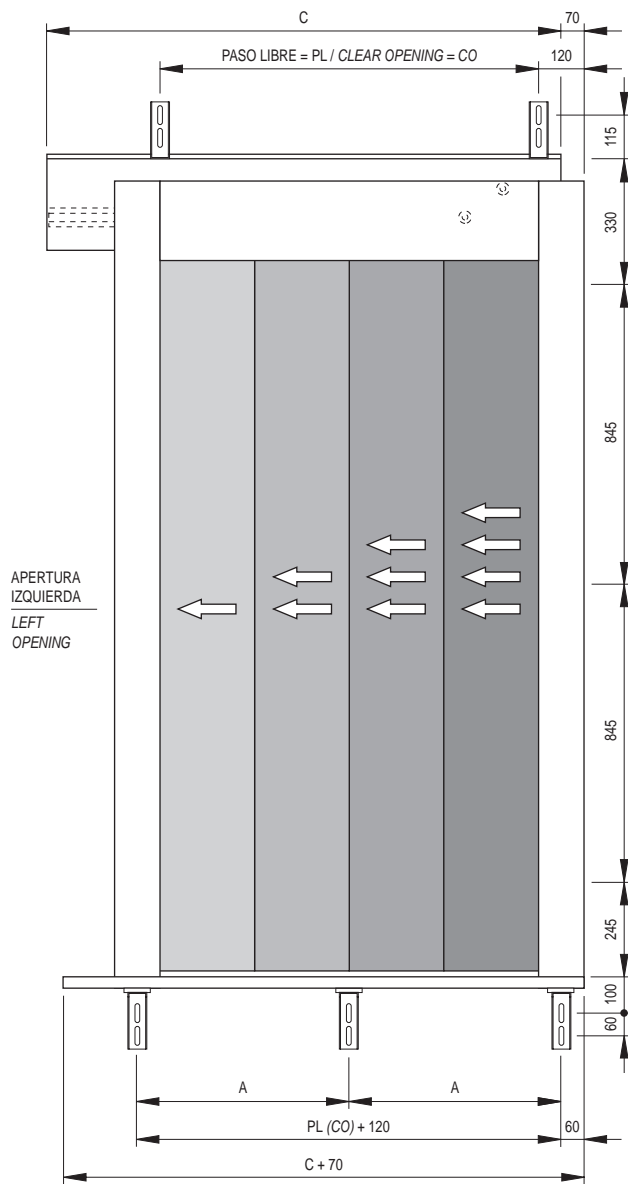

| PL / CO | 600 | 650 | 700 | 750 | 800 | 850 | 900 | 1000 | 1100 | 1200 | 1300 | 1400 | 1500 | 1600 | 1700 | 1800 | 1900 | 2000 |
|---------|-----|-----|-----|------|------|------|------|------|------|------|------|------|------|------|------|------|------|------|
| A | 360 | 385 | 410 | 435 | 460 | 485 | 340 | 373 | 407 | 330 | 355 | 380 | 324 | 344 | 303 | 320 | 337 | 303 |
| B | 100 | 100 | 100 | 100 | 100 | 100 | 100 | 160 | 160 | 160 | 160 | 160 | 160 | 160 | 160 | 160 | 160 | 160 |
| C | 850 | 915 | 975 | 1040 | 1100 | 1165 | 1225 | 1350 | 1475 | 1600 | 1725 | 1850 | 1975 | 2100 | 2225 | 2350 | 2475 | 2600 |
| S | 3 | 3 | 3 | 3 | 3 | 3 | 3 | 3 | 4 | 4 | 4 | 4 | 4 | 4 | 5 | 5 | 5 | 5 |
| T | 5 | 5 | 5 | 5 | 5 | 5 | 5 | 5 | 6 | 7 | 7 | 7 | 7 | 7 | 8 | 9 | 9 | 9 |

S: N°. de soportes en apoyo pisadera.
S: Number of supports for sill support.

T: N°. de soportes total.
T: Total number of supports.

Puerta rellano telescópica 4 hojas modelo 40/10
4 panel side opening landing door model 40/10

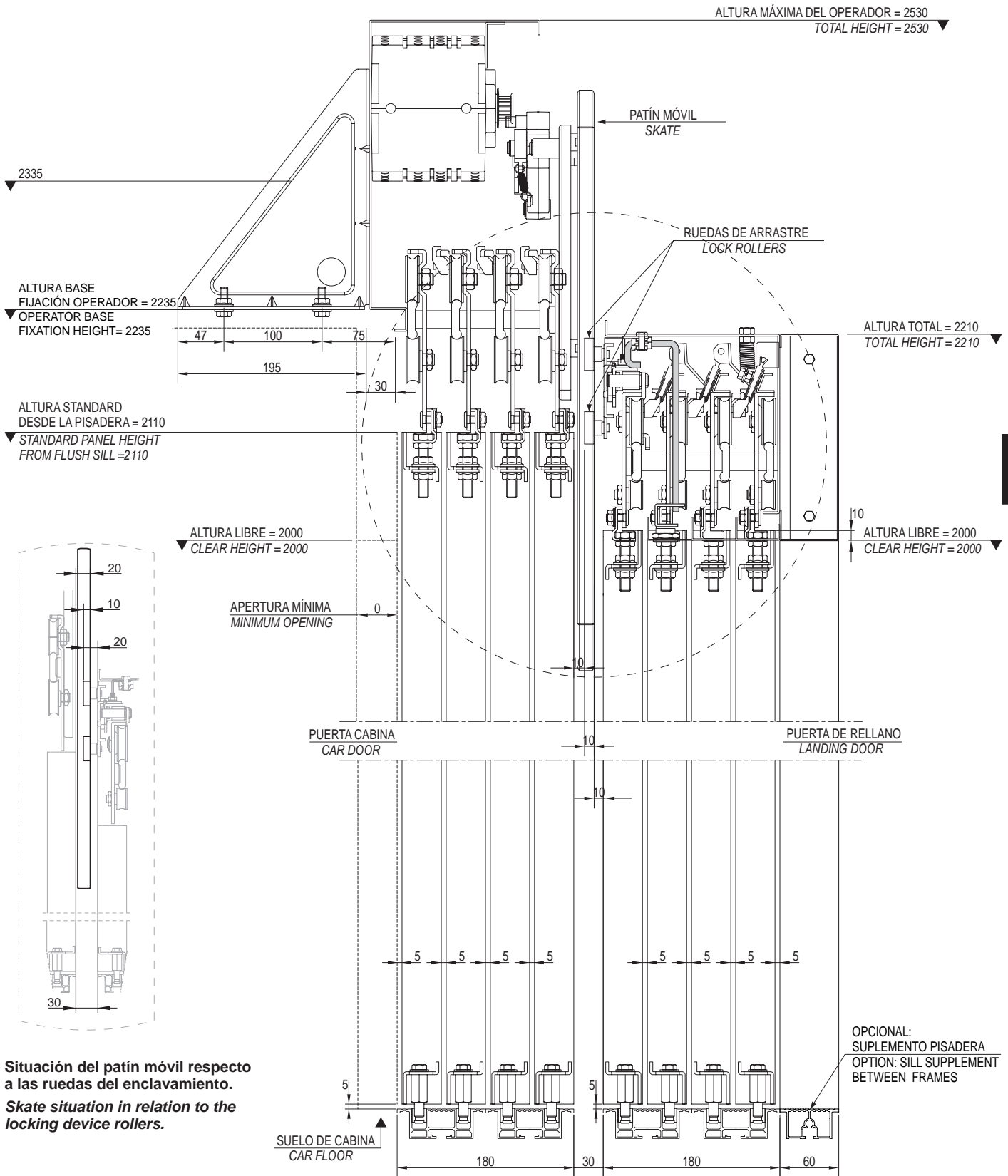

Situación del patín móvil respecto a las ruedas del enclavamiento.
Skate situation in relation to the locking device rollers.

8.6.

SITUACIÓN DEL PATÍN CON LAS RUEDAS DE ARRASTRE COUPLING ARRANGEMENT BETWEEN SKATE AND LOCK

Puerta rellano telescópica 4 hojas modelo 50/11
4 panel side opening landing door model 50/11

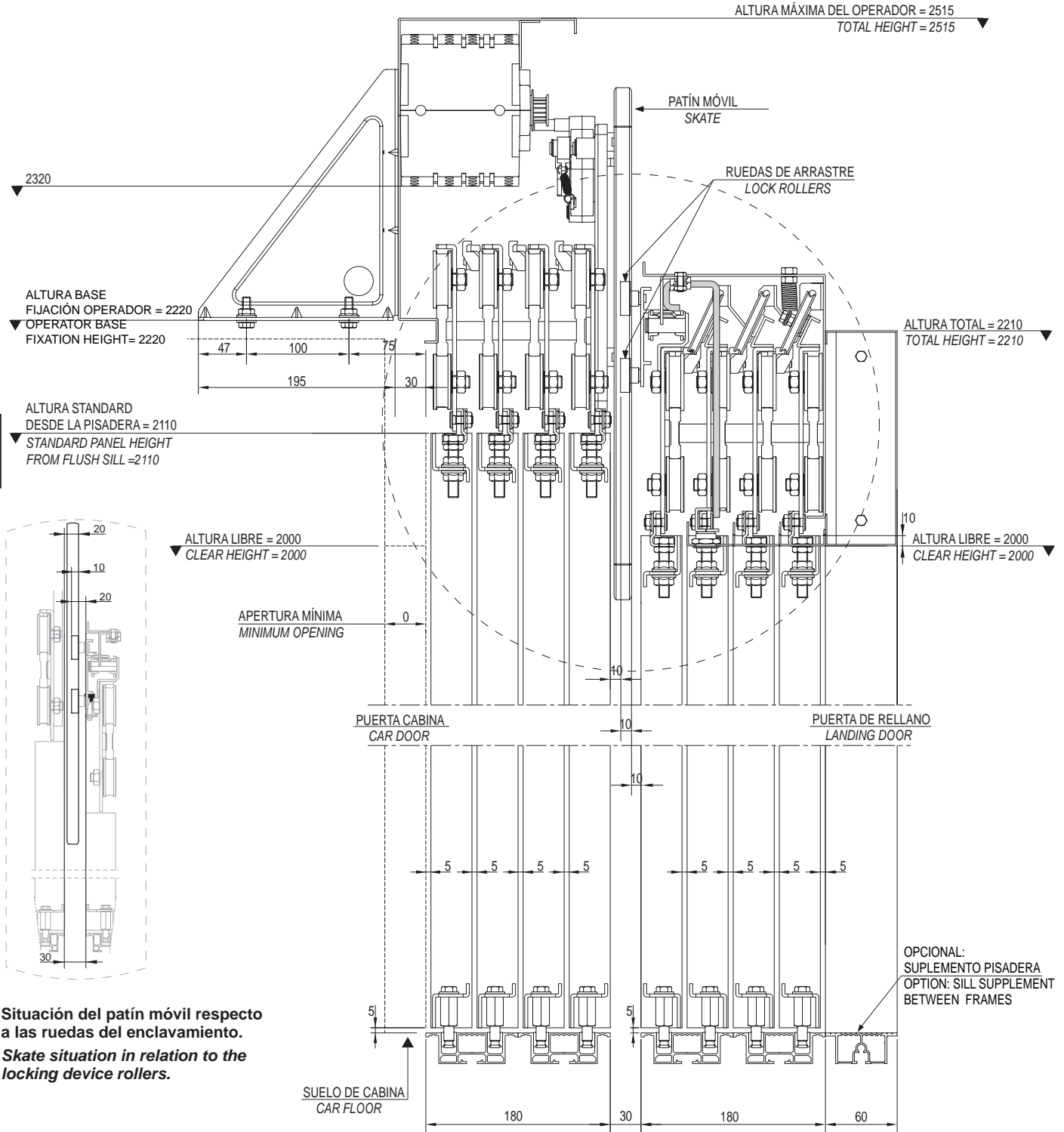

Situación del patín móvil respecto a las ruedas del enclavamiento.
Skate situation in relation to the locking device rollers.

PUERTA DE CRISTAL GLASS DOOR

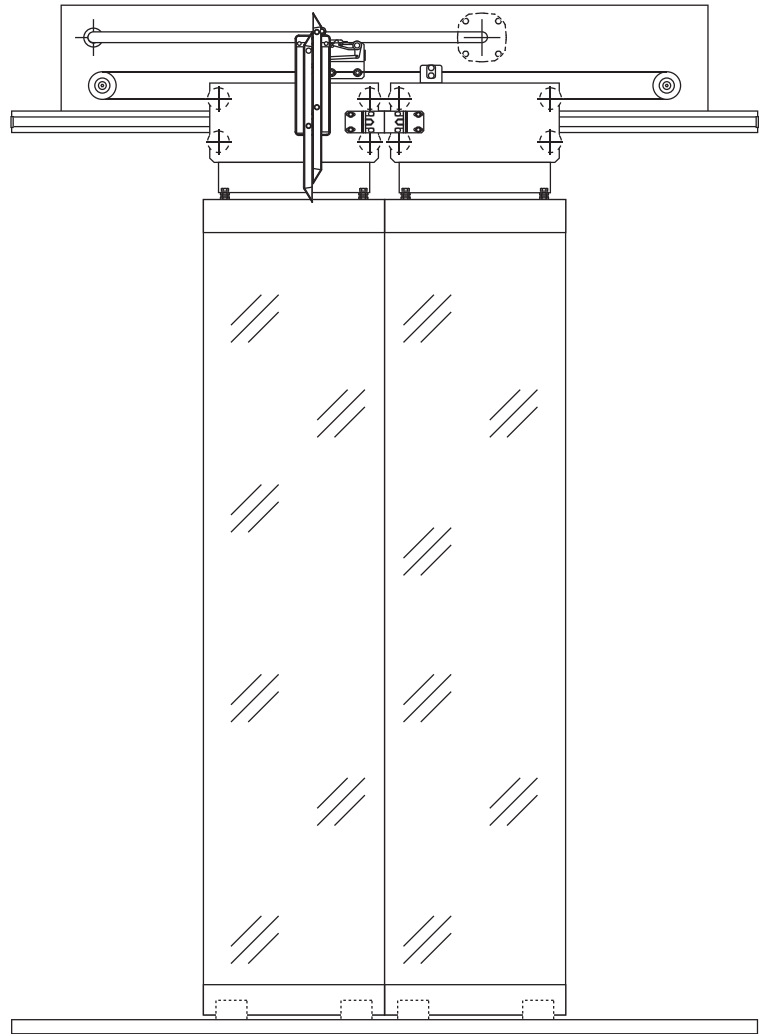

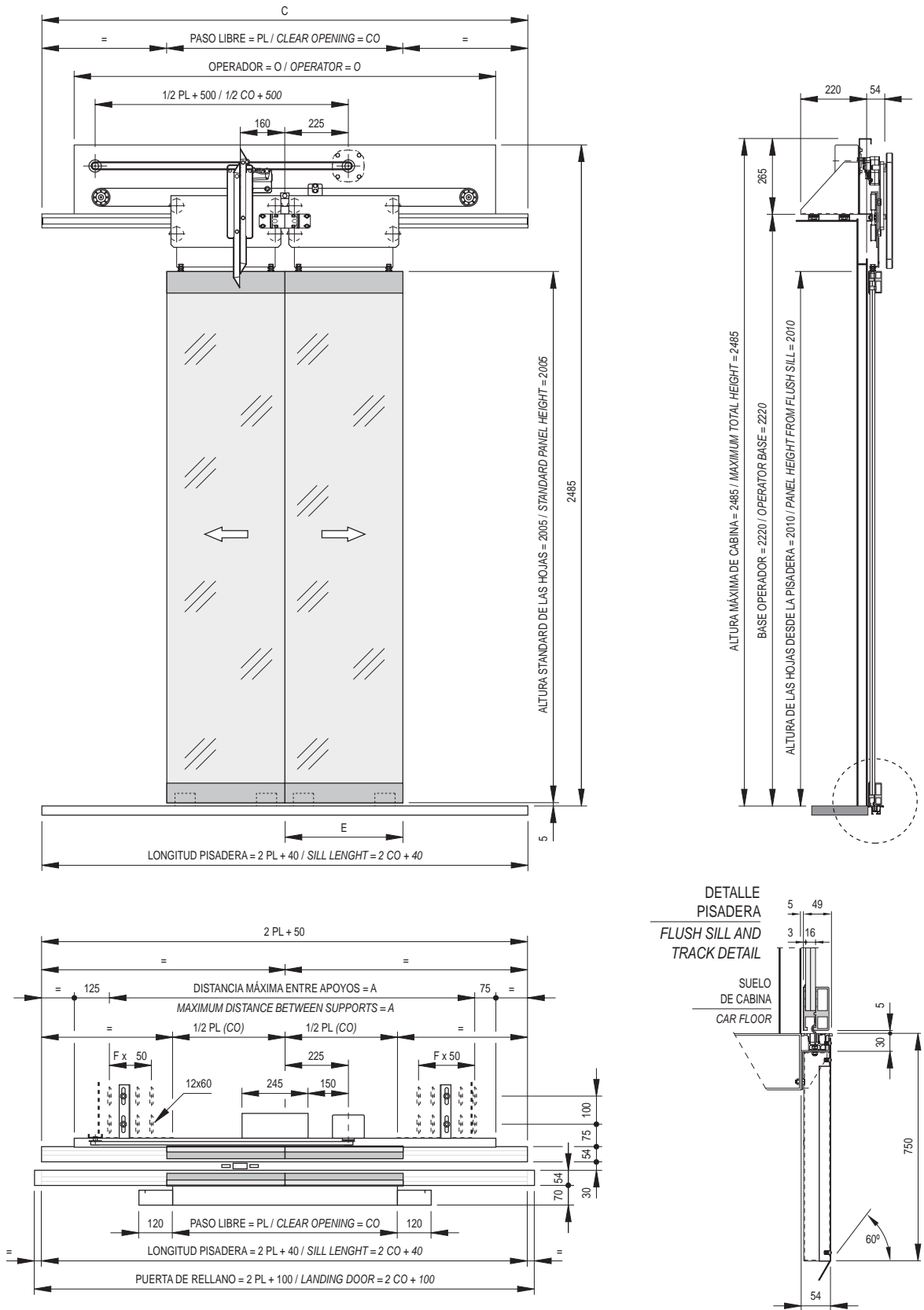

| PL / CO | 600 | 650 | 700 | 750 | 800 | 850 | 900 | 1000 | 1100 | 1200 |
|--------------------|-------|-------|--------|--------|--------|--------|--------|--------|--------|--------|
| A | 1000 | 1050 | 1200 | 1250 | 1300 | 1350 | 1400 | 1500 | 1600 | 2000 |
| C | 1250 | 1350 | 1450 | 1550 | 1650 | 1750 | 1850 | 2050 | 2250 | 2450 |
| O | 1200 | 1250 | 1400 | 1450 | 1500 | 1550 | 1600 | 1700 | 1800 | 2200 |
| E | 320 | 345 | 370 | 395 | 420 | 445 | 470 | 520 | 570 | 620 |
| F | 4 | 4 | 5 | 6 | 6 | 7 | 7 | 8 | 9 | 13 |
| PESO / WEIGHT (kg) | 88'13 | 95'46 | 102'81 | 110'16 | 117'50 | 124'84 | 132'19 | 146'88 | 161'56 | 176'25 |

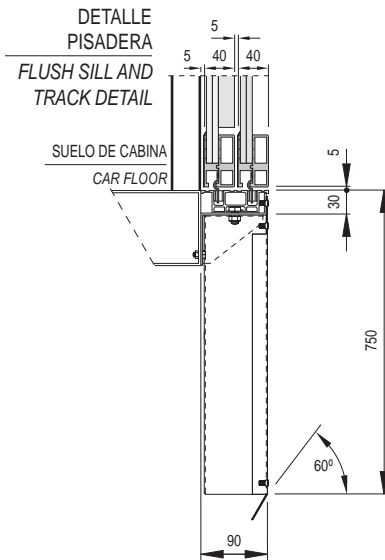
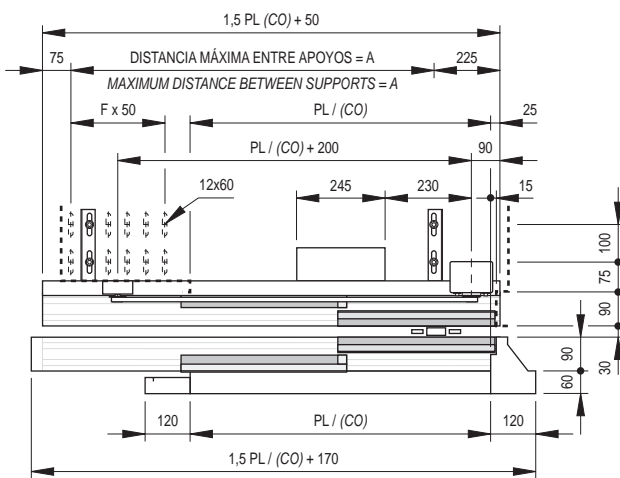
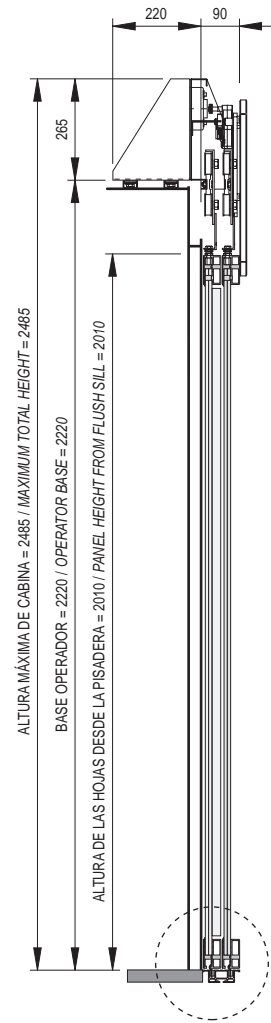
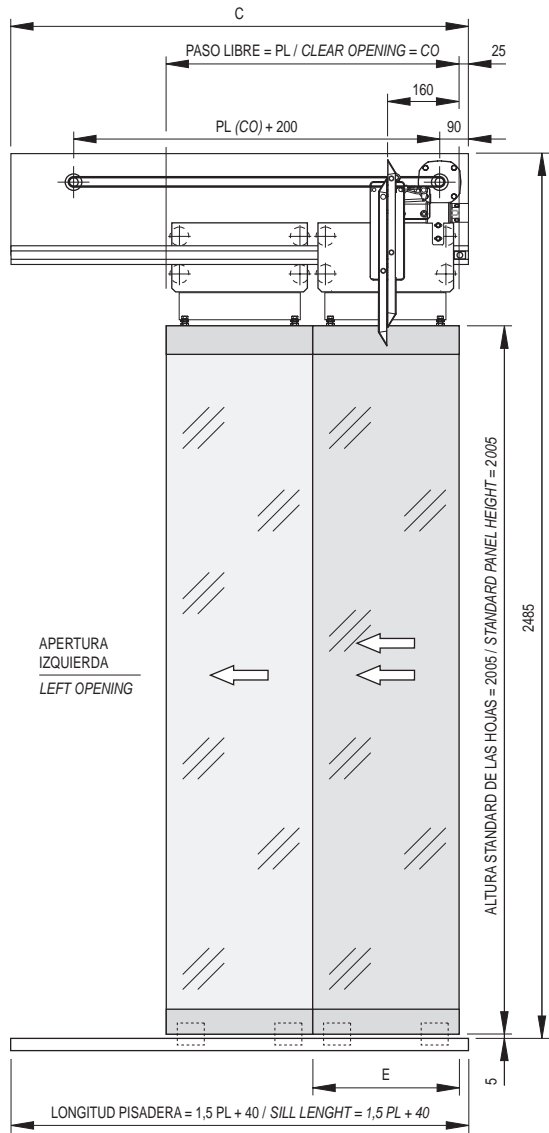

| PL / CO | 600 | 650 | 700 | 750 | 800 | 850 | 900 | 1000 | 1100 | 1200 |
|--------------------|--------|--------|--------|--------|--------|--------|--------|--------|--------|--------|
| A | 650 | 725 | 800 | 875 | 950 | 1025 | 1100 | 1250 | 1400 | 1550 |
| C | 950 | 1025 | 1100 | 1175 | 1250 | 1325 | 1400 | 1550 | 1700 | 1850 |
| E | 320 | 345 | 370 | 395 | 420 | 445 | 470 | 520 | 570 | 620 |
| F | 4 | 4 | 5 | 5 | 6 | 6 | 6 | 7 | 8 | 8 |
| PESO / WEIGHT (kg) | 102'75 | 109'44 | 116'13 | 122'81 | 129'50 | 136'19 | 142'88 | 156'25 | 169'63 | 183'00 |

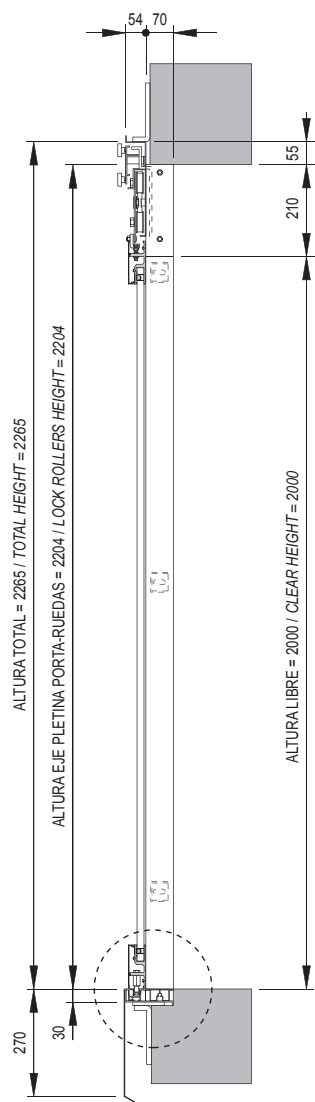
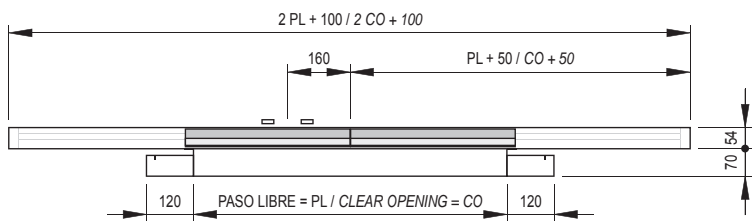
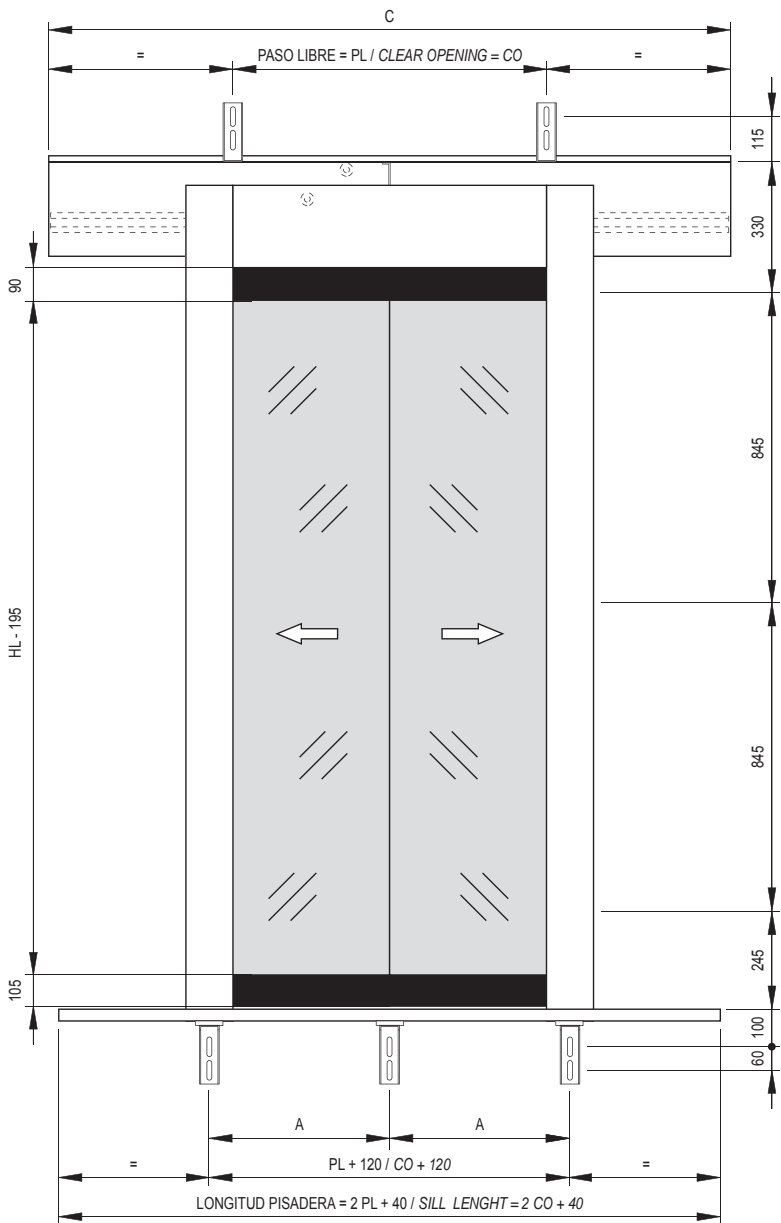

DETALLE PISADERA
FLUSH SILL AND TRACK DETAIL

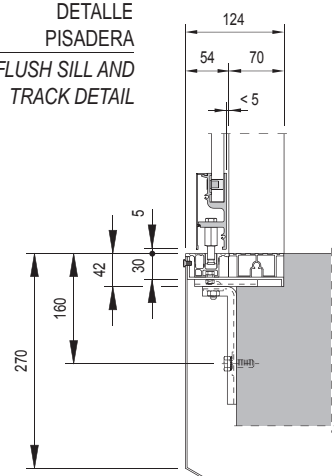

9

| PL / CO | 600 | 650 | 700 | 750 | 800 | 850 | 900 | 1000 | 1100 | 1200 | 1300 | 1400 | 1500 | 1600 | 1700 | 1800 | 1900 | 2000 |
|---------|------|------|------|------|------|------|------|------|------|------|------|------|------|------|------|------|------|------|
| C | 1300 | 1400 | 1500 | 1600 | 1700 | 1800 | 1900 | 2100 | 2300 | 2500 | 2700 | 2900 | 3100 | 3300 | 3500 | 3700 | 3900 | 4100 |
| A | 360 | 385 | 410 | 435 | 460 | 485 | 340 | 373 | 407 | 330 | 355 | 380 | 324 | 344 | 303 | 320 | 337 | 303 |
| S | 3 | 3 | 3 | 3 | 3 | 3 | 4 | 4 | 4 | 5 | 5 | 5 | 6 | 6 | 7 | 7 | 7 | 8 |
| T | 5 | 5 | 5 | 5 | 5 | 5 | 6 | 6 | 6 | 8 | 8 | 8 | 9 | 9 | 10 | 11 | 11 | 12 |

S: N°. de soportes en apoyo pisadera.
S: Number of supports for sill support.

T: N°. de soportes total.
T: Total number of supports.

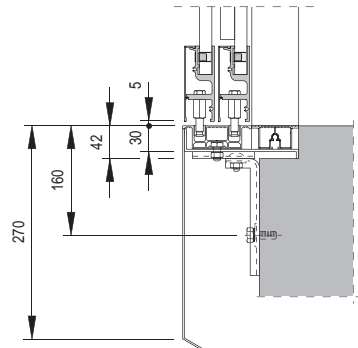
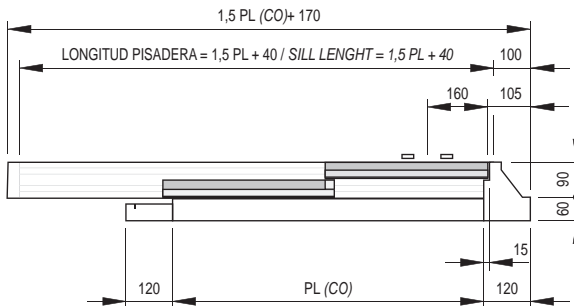
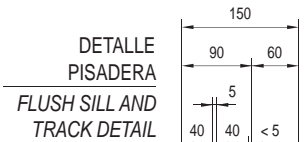
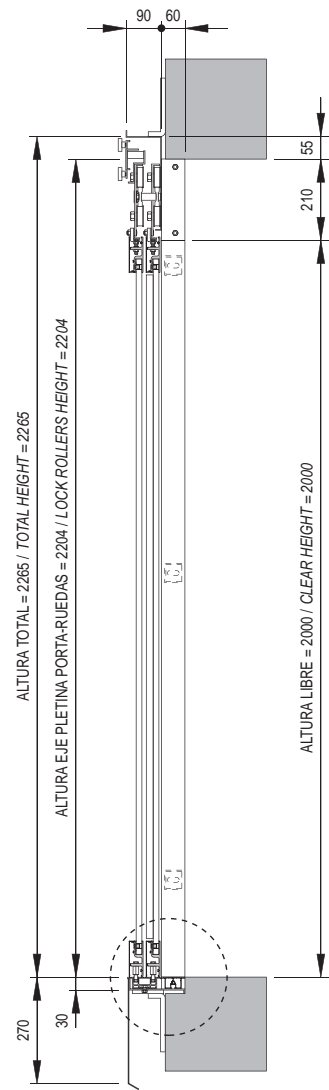
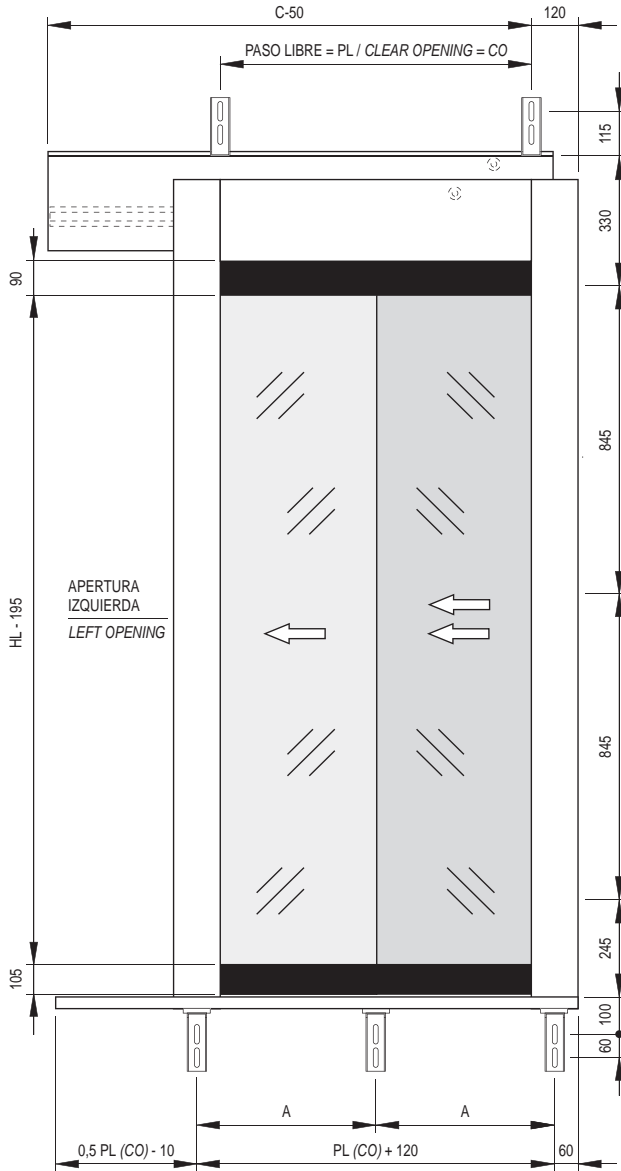

| PL / CO | 600 | 650 | 700 | 750 | 800 | 850 | 900 | 1000 | 1100 | 1200 | 1300 | 1400 | 1500 | 1600 |
|---------|------|------|------|------|------|------|------|------|------|------|------|------|------|------|
| C | 1000 | 1075 | 1150 | 1225 | 1300 | 1375 | 1450 | 1600 | 1750 | 1900 | 2050 | 2200 | 2350 | 2500 |
| A | 360 | 385 | 410 | 435 | 460 | 485 | 340 | 373 | 407 | 330 | 355 | 380 | 324 | 344 |
| S | 3 | 3 | 3 | 3 | 3 | 3 | 4 | 4 | 4 | 5 | 5 | 5 | 6 | 6 |
| T | 5 | 5 | 5 | 5 | 5 | 5 | 6 | 6 | 6 | 8 | 8 | 8 | 9 | 9 |

S: N°. de soportes en apoyo pisadera.
S: Number of supports for sill support.

T: N°. de soportes total.
T: Total number of supports.

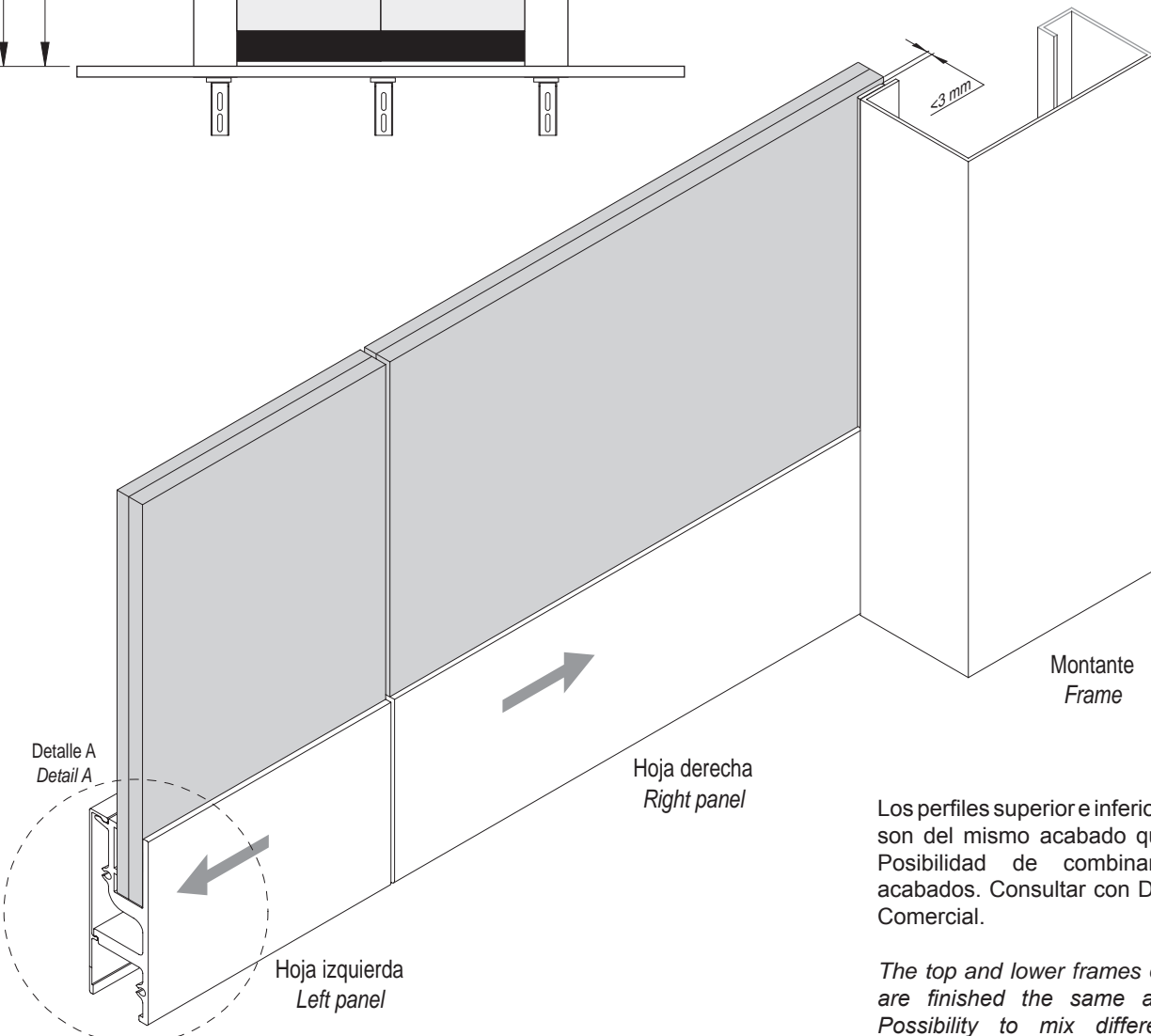
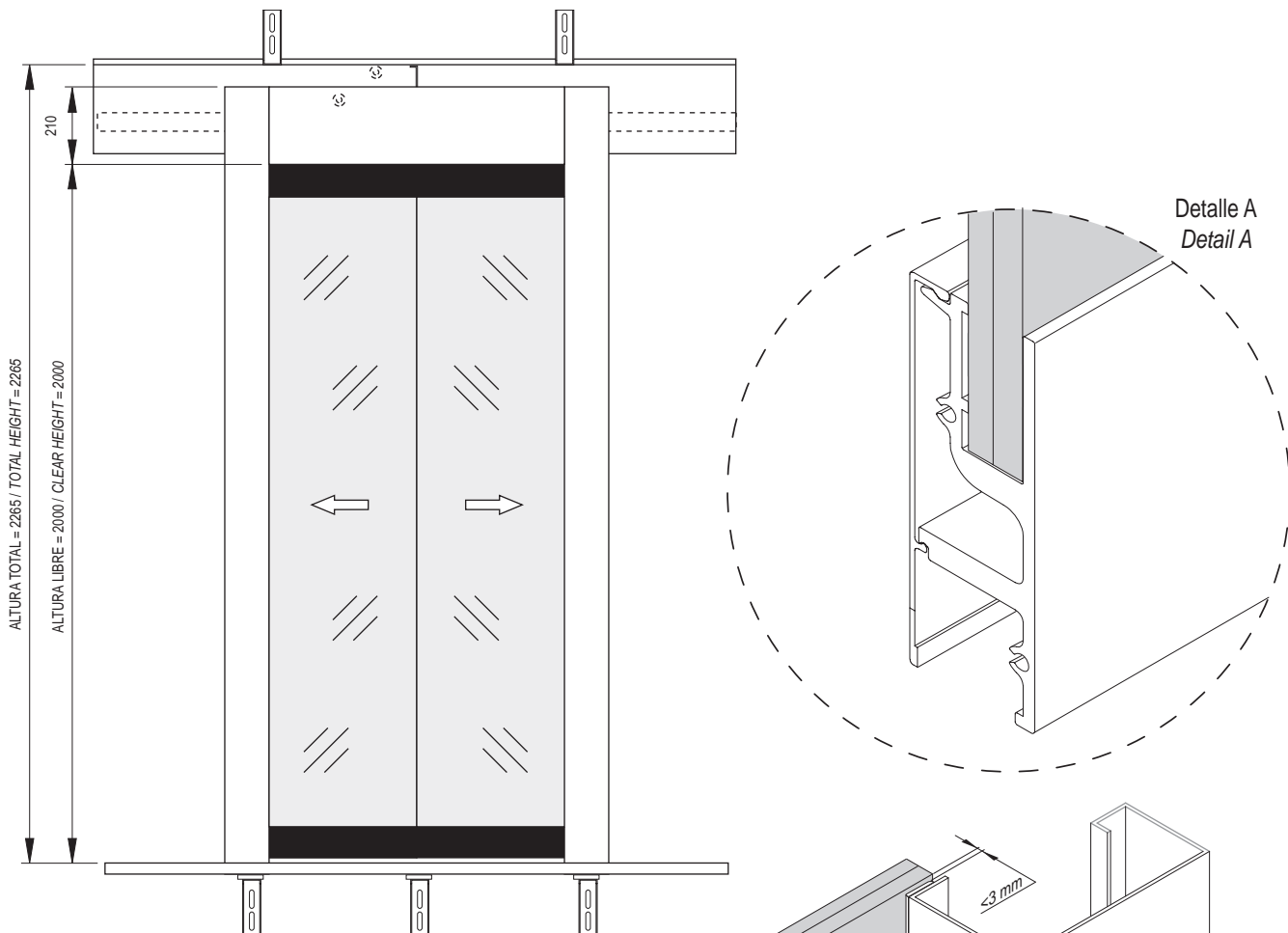

Los perfiles superior e inferior de las hojas son del mismo acabado que la puerta. Posibilidad de combinar diferentes acabados. Consultar con Departamento Comercial.

The top and lower frames of the panels are finished the same as the door. Possibility to mix different finishes. Contact our Commercial Department.

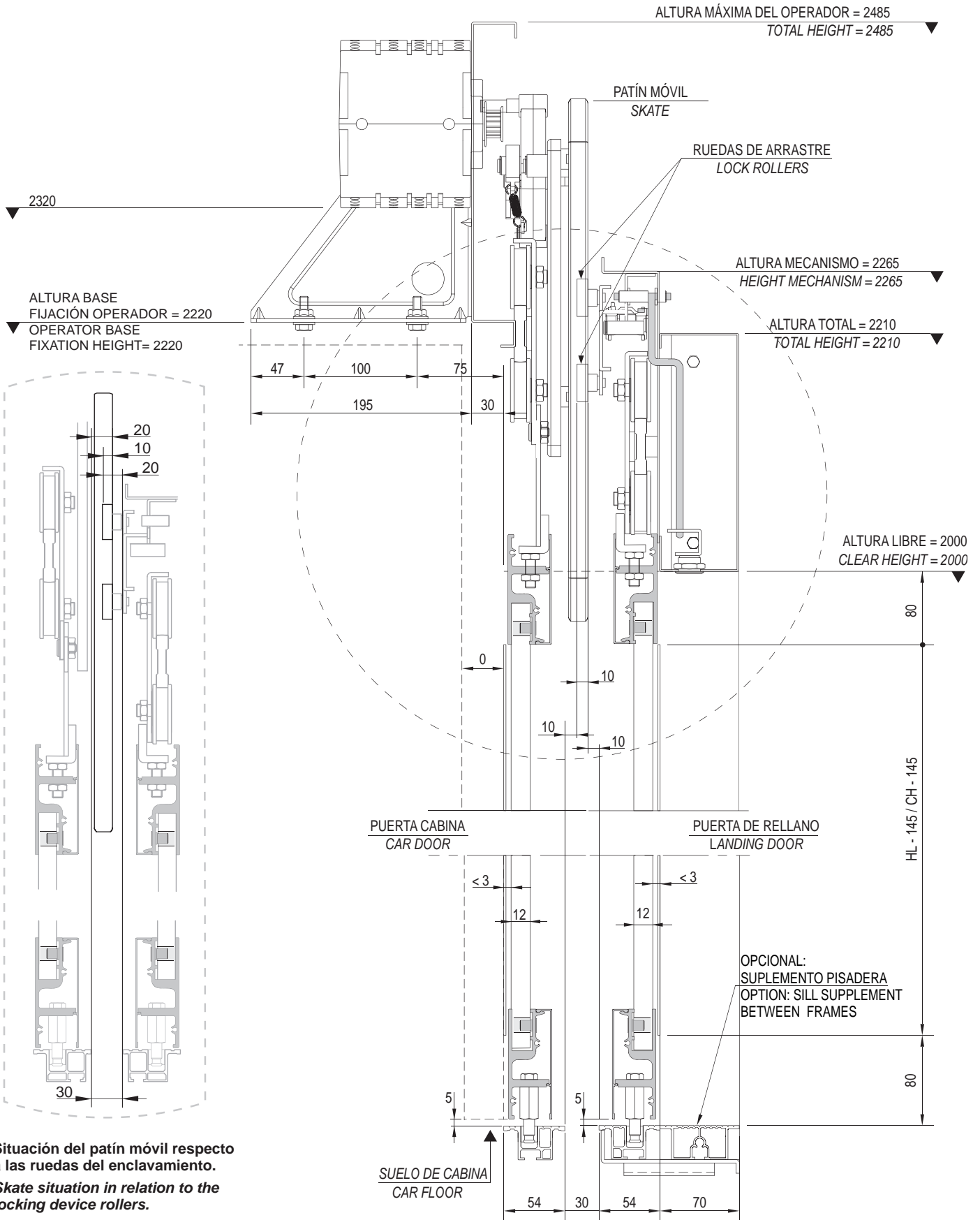

Situación del patín móvil respecto a las ruedas del enclavamiento.
Skate situation in relation to the locking device rollers.

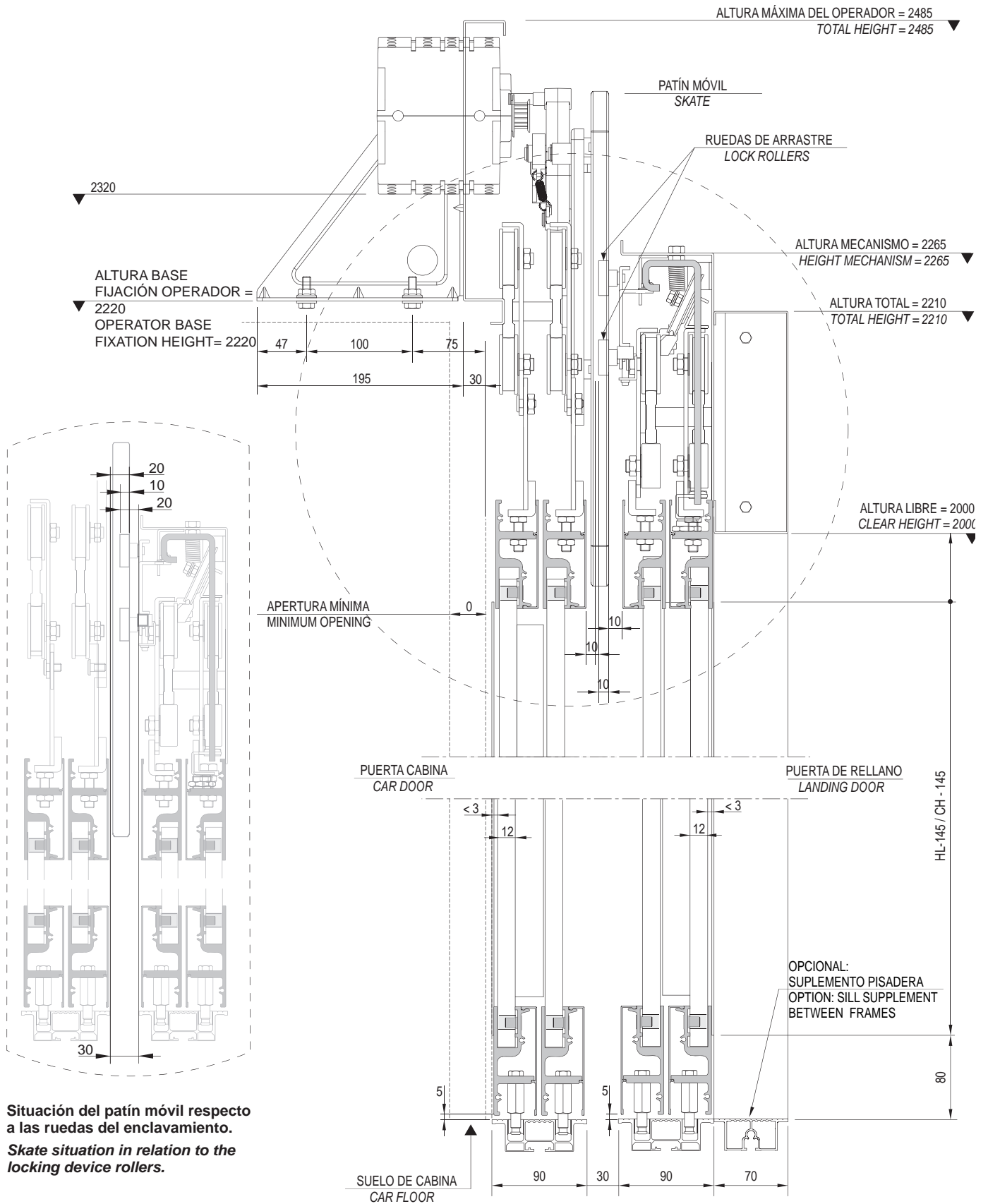

Situación del patín móvil respecto a las ruedas del enclavamiento.
Skate situation in relation to the locking device rollers.

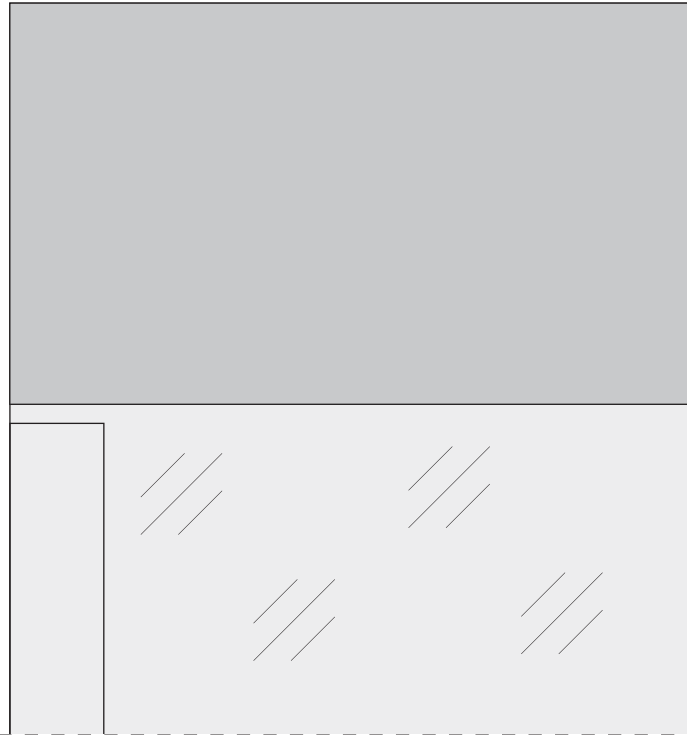

ANCHURA DE LA HOJA = E
PANEL WIDTH = E

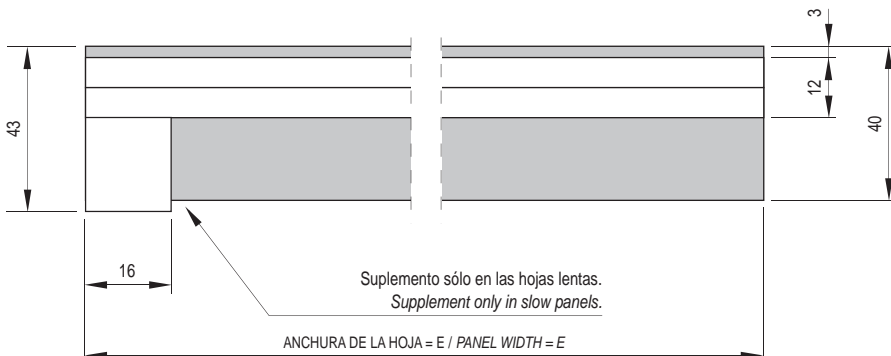
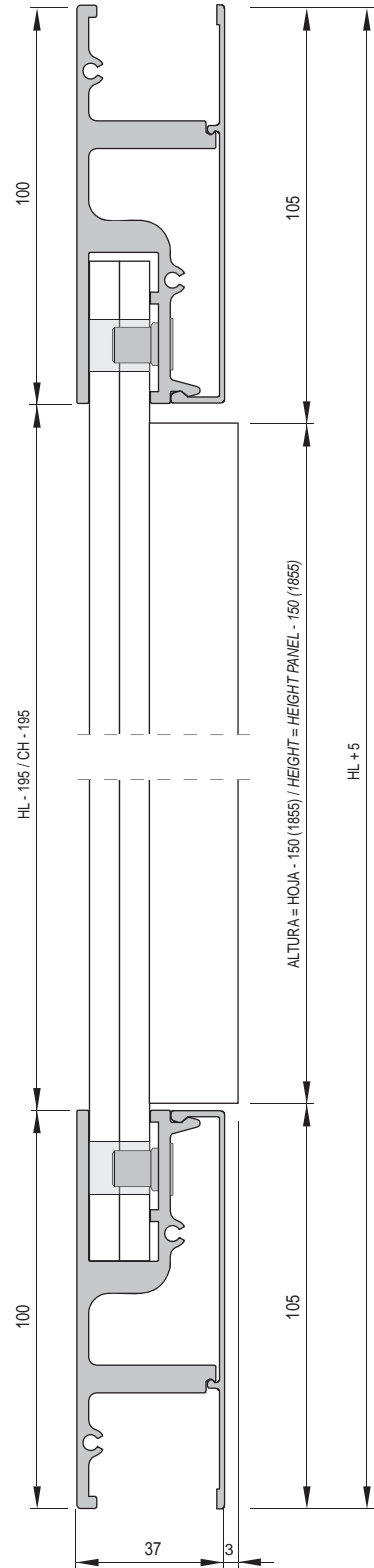

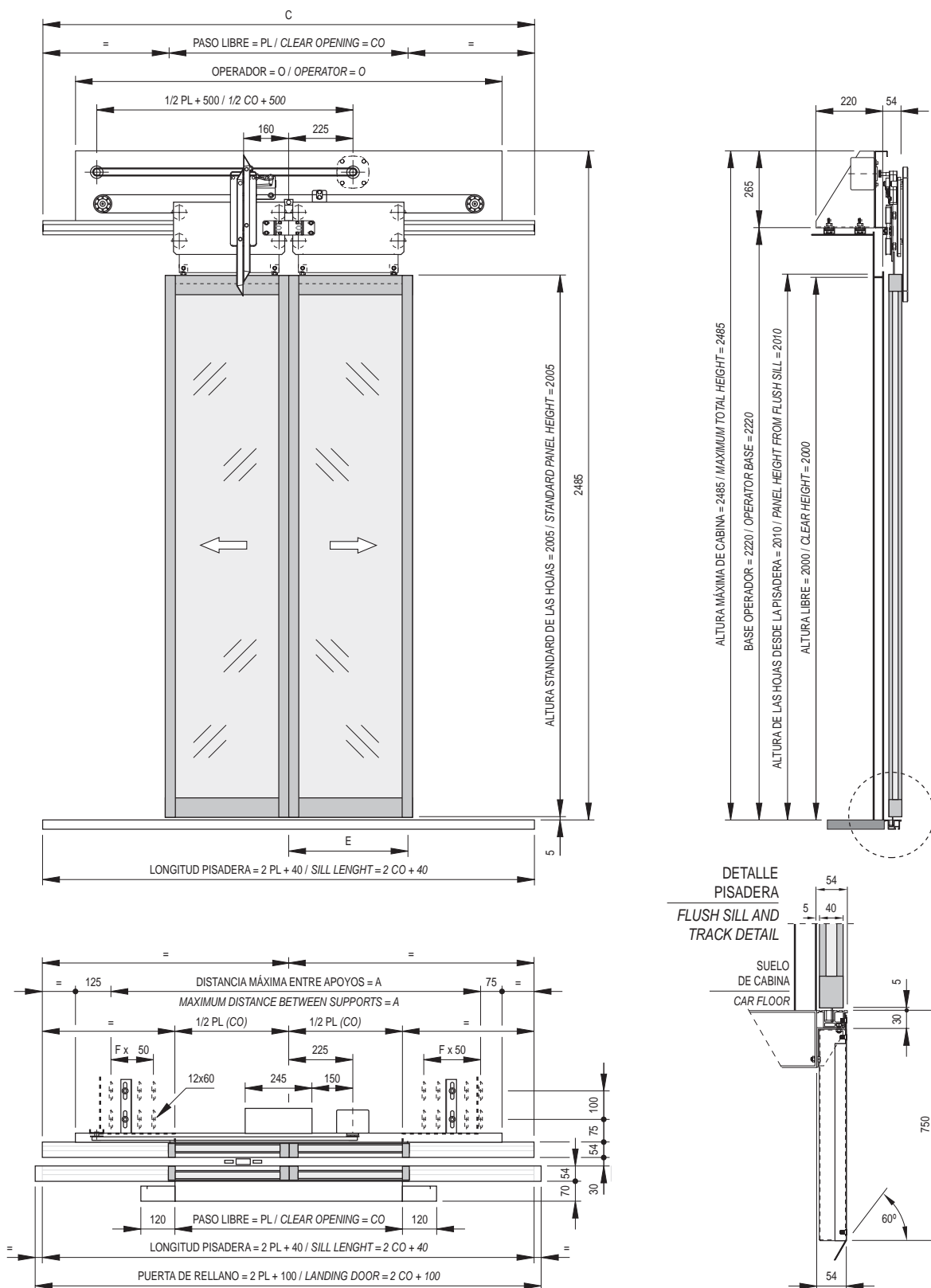

| PL / CO | 600 | 650 | 700 | 750 | 800 | 850 | 900 | 1000 | 1100 | 1200 |
|--------------------|------|------|------|------|------|------|------|------|------|------|
| A | 1000 | 1050 | 1200 | 1250 | 1300 | 1350 | 1400 | 1500 | 1600 | 2000 |
| C | 1250 | 1350 | 1450 | 1550 | 1650 | 1750 | 1850 | 2050 | 2250 | 2450 |
| O | 1200 | 1250 | 1400 | 1450 | 1500 | 1550 | 1600 | 1700 | 1800 | 2200 |
| E | 320 | 345 | 370 | 395 | 420 | 445 | 470 | 520 | 570 | 620 |
| F | 4 | 4 | 5 | 6 | 6 | 7 | 7 | 8 | 9 | 13 |
| PESO / WEIGHT (kg) | 70 | 76 | 82 | 88 | 94 | 99 | 105 | 117 | 129 | 140 |

9.10.

PUERTA DE CRISTAL CON PERFIL DE ALUMINIO GLASS DOOR WITH ALUMINIUM PROFILE

Fermator

AUTOMATIC DOORS FOR LIFTS

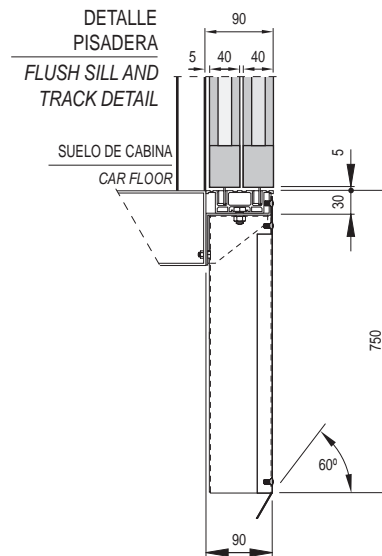
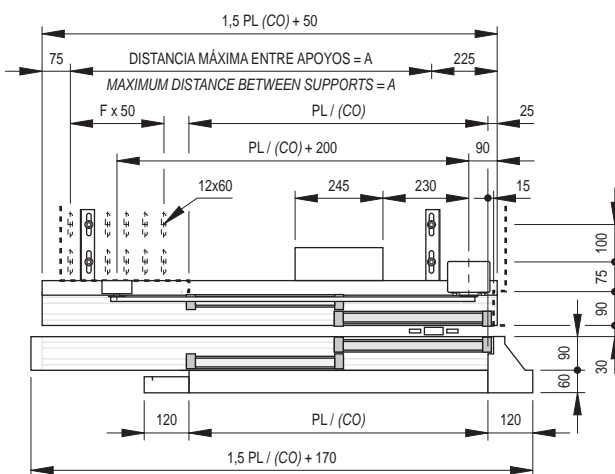
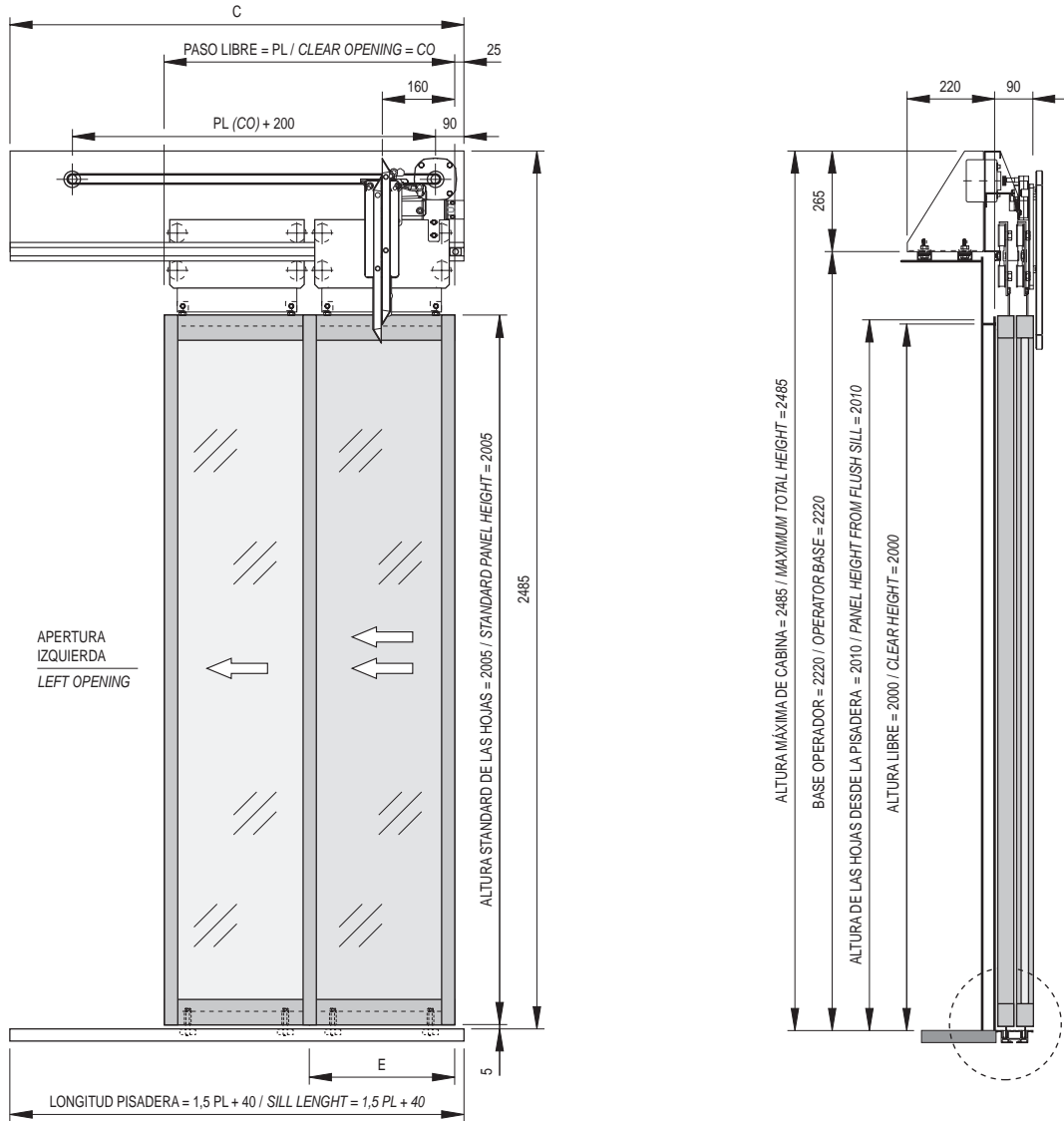

| PL / CO | 600 | 650 | 700 | 750 | 800 | 850 | 900 | 1000 | 1100 | 1200 |
|--------------------|-----|------|------|------|------|------|------|------|------|------|
| A | 650 | 725 | 800 | 875 | 950 | 1025 | 1100 | 1250 | 1400 | 1550 |
| C | 950 | 1025 | 1100 | 1175 | 1250 | 1325 | 1400 | 1550 | 1700 | 1850 |
| E | 320 | 345 | 370 | 395 | 420 | 445 | 470 | 520 | 570 | 620 |
| F | 4 | 4 | 5 | 5 | 6 | 6 | 6 | 7 | 8 | 8 |
| PESO / WEIGHT (kg) | 71 | 77 | 83 | 89 | 95 | 100 | 106 | 118 | 130 | 142 |

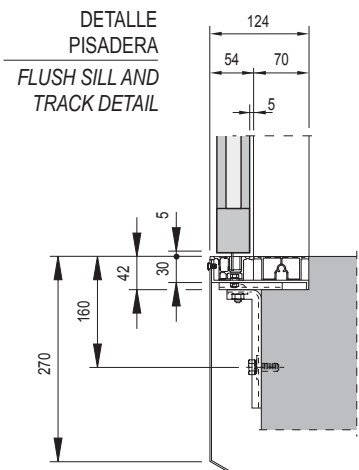
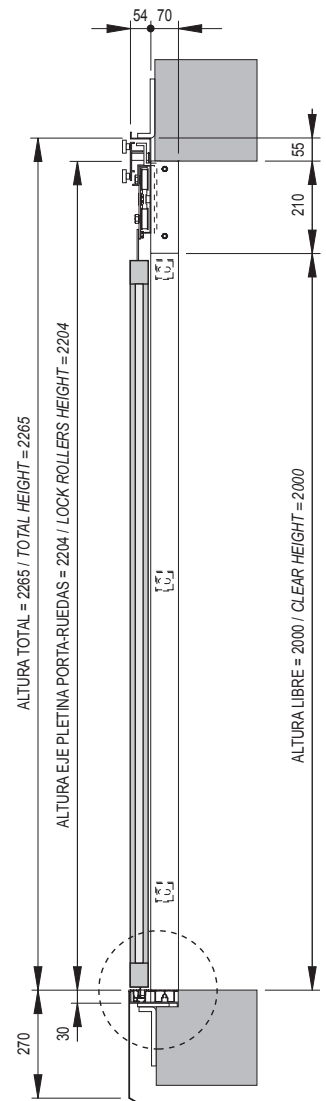
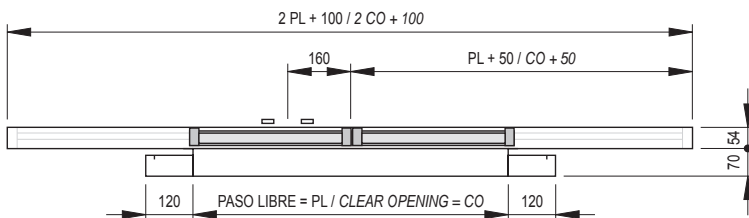
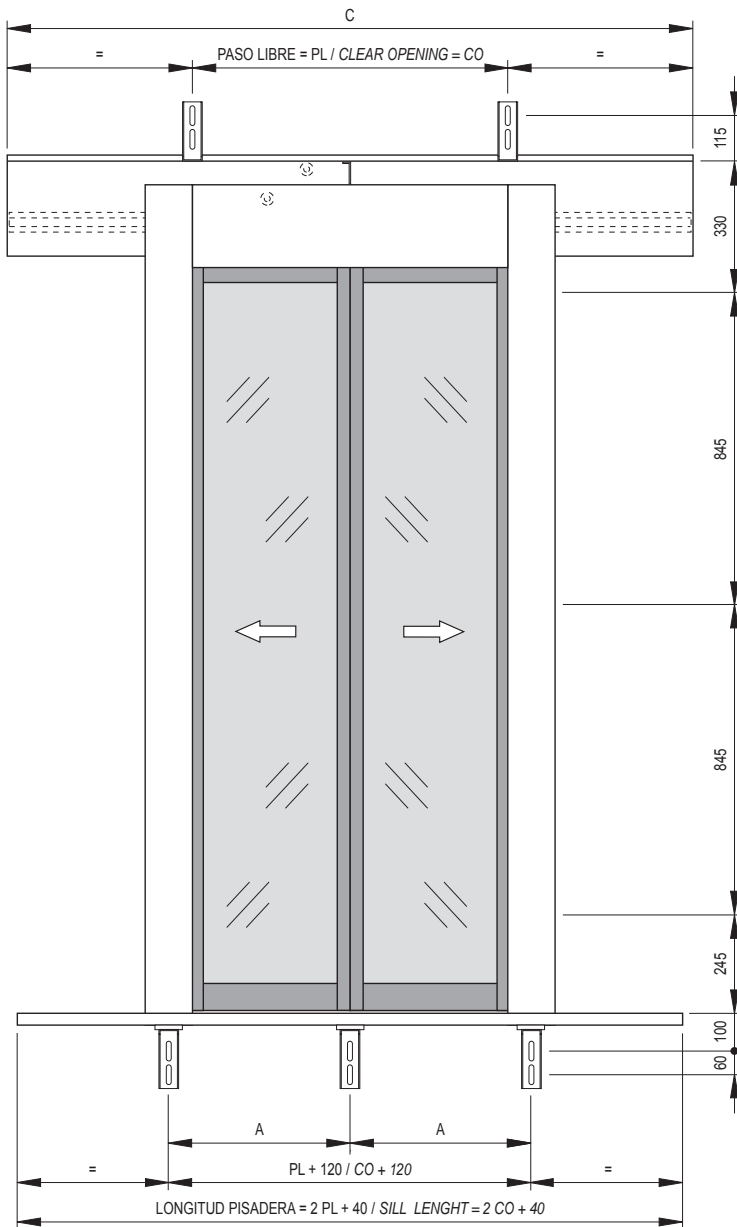

| PL / CO | 600 | 650 | 700 | 750 | 800 | 850 | 900 | 1000 | 1100 | 1200 | 1300 | 1400 | 1500 | 1600 | 1700 | 1800 | 1900 | 2000 |
|---------|------|------|------|------|------|------|------|------|------|------|------|------|------|------|------|------|------|------|
| C | 1300 | 1400 | 1500 | 1600 | 1700 | 1800 | 1900 | 2100 | 2300 | 2500 | 2700 | 2900 | 3100 | 3300 | 3500 | 3700 | 3900 | 4100 |
| A | 360 | 385 | 410 | 435 | 460 | 485 | 340 | 373 | 407 | 330 | 355 | 380 | 324 | 344 | 303 | 320 | 337 | 303 |
| S | 3 | 3 | 3 | 3 | 3 | 3 | 4 | 4 | 4 | 5 | 5 | 5 | 6 | 6 | 7 | 7 | 7 | 8 |
| T | 5 | 5 | 5 | 5 | 5 | 5 | 6 | 6 | 6 | 8 | 8 | 8 | 9 | 9 | 10 | 11 | 11 | 12 |

S: N°. de soportes en apoyo pisadera.
S: Number of supports for sill support.

T: N°. de soportes total.
T: Total number of supports.

9.12.

PUERTA TELESCÓPICA DE RELLANO DE CRISTAL CON PERFIL DE ALUMINIO TELESCOPIC LANDING GLASS DOOR WITH ALUMINIUM PROFILE

Fermator
AUTOMATIC DOORS FOR LIFTS

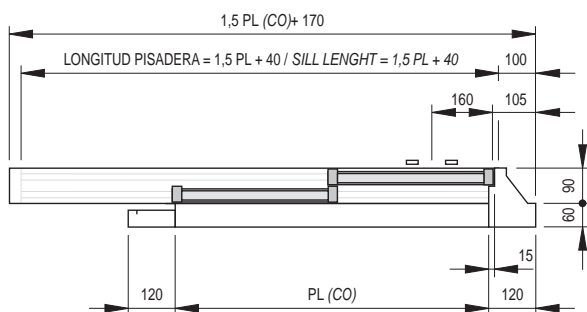
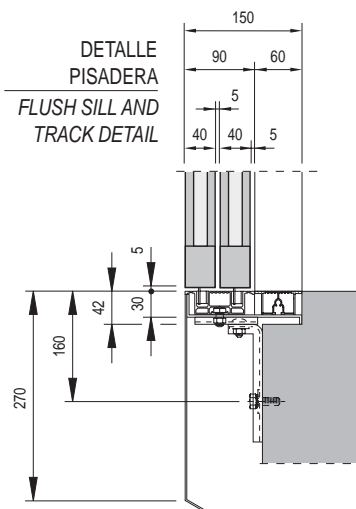
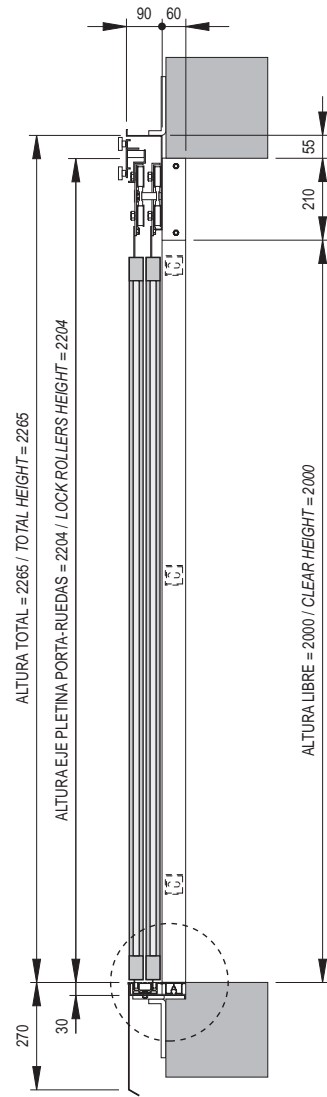
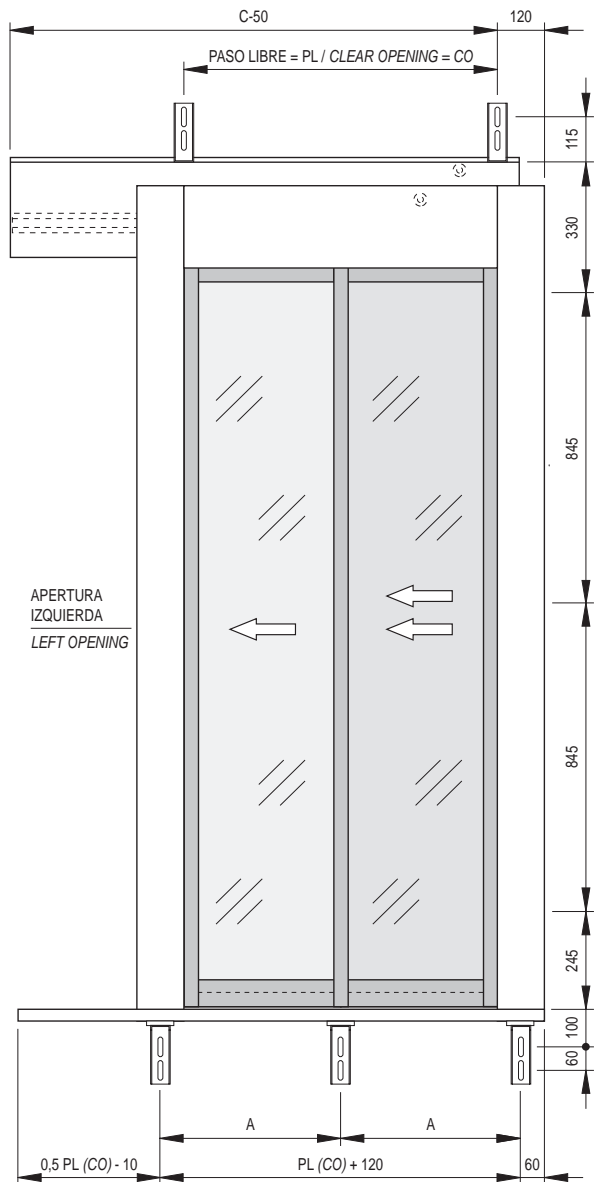

| PL / CO | 600 | 650 | 700 | 750 | 800 | 850 | 900 | 1000 | 1100 | 1200 | 1300 | 1400 | 1500 | 1600 |
|---------|------|------|------|------|------|------|------|------|------|------|------|------|------|------|
| C | 1000 | 1075 | 1150 | 1225 | 1300 | 1375 | 1450 | 1600 | 1750 | 1900 | 2050 | 2200 | 2350 | 2500 |
| A | 360 | 385 | 410 | 435 | 460 | 485 | 340 | 373 | 407 | 330 | 355 | 380 | 324 | 344 |
| S | 3 | 3 | 3 | 3 | 3 | 3 | 4 | 4 | 4 | 5 | 5 | 5 | 6 | 6 |
| T | 5 | 5 | 5 | 5 | 5 | 5 | 6 | 6 | 6 | 8 | 8 | 8 | 9 | 9 |

S: N°. de soportes en apoyo pisadera.
S: Number of supports for sill support.

T: N°. de soportes total.
T: Total number of supports.

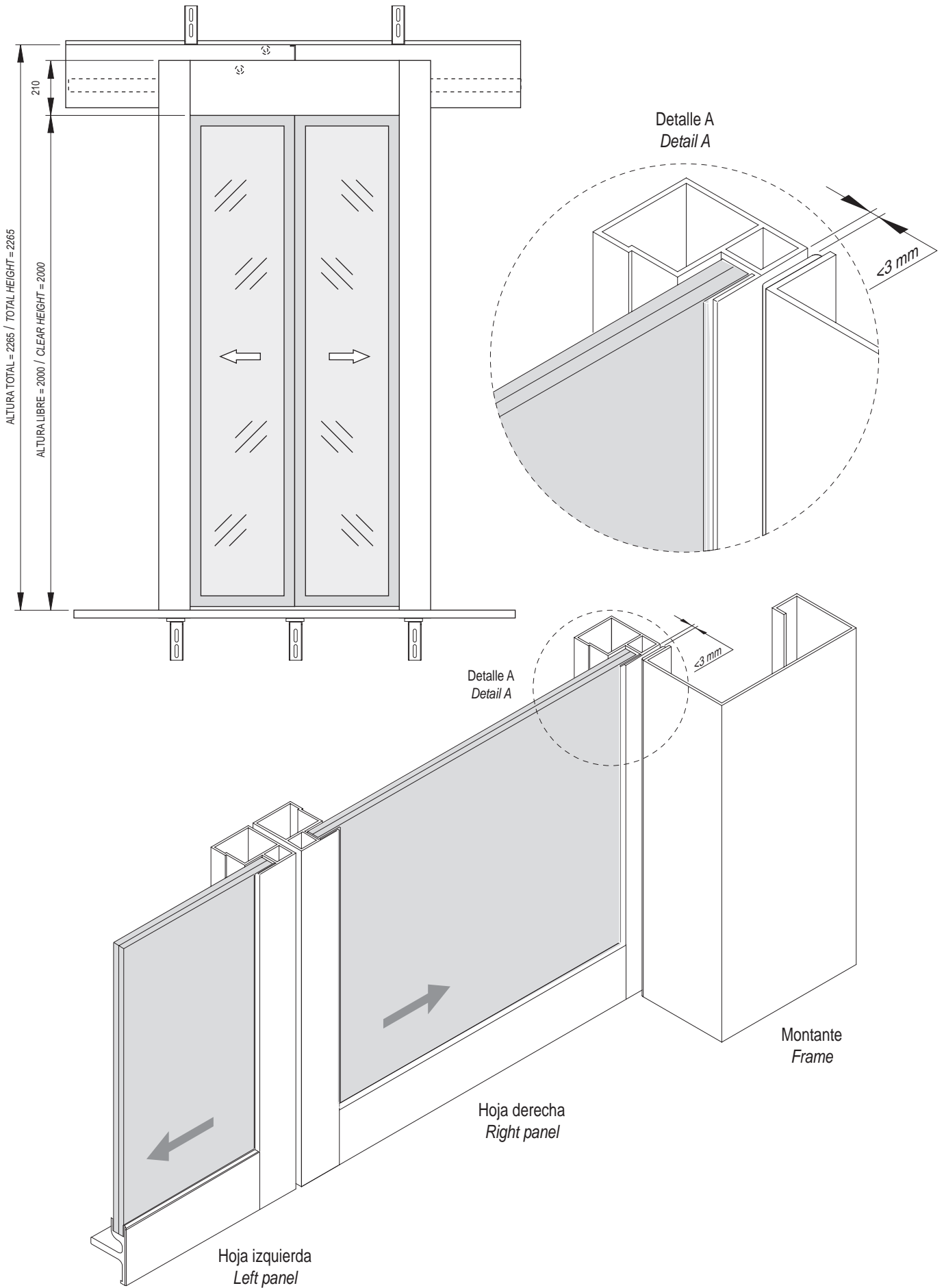

9.14.

DETALLE HOJA DE CRISTAL CON PERFIL DE ALUMINIO GLASS PANEL WITH ALUMINIUM PROFILE DETAIL

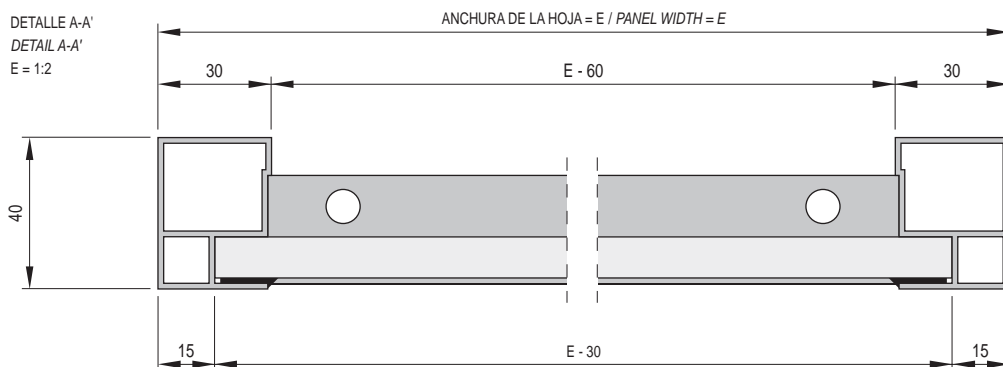
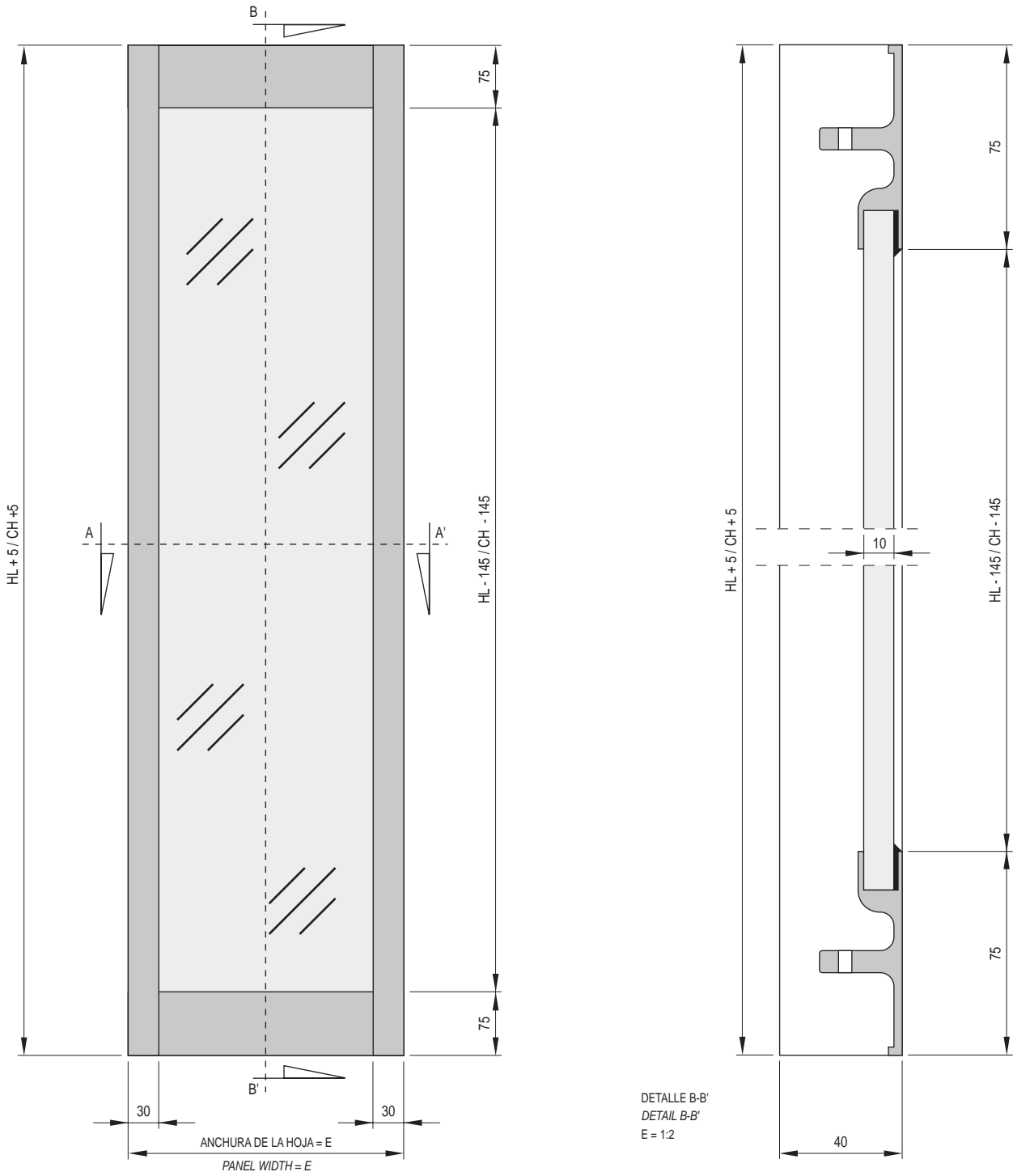

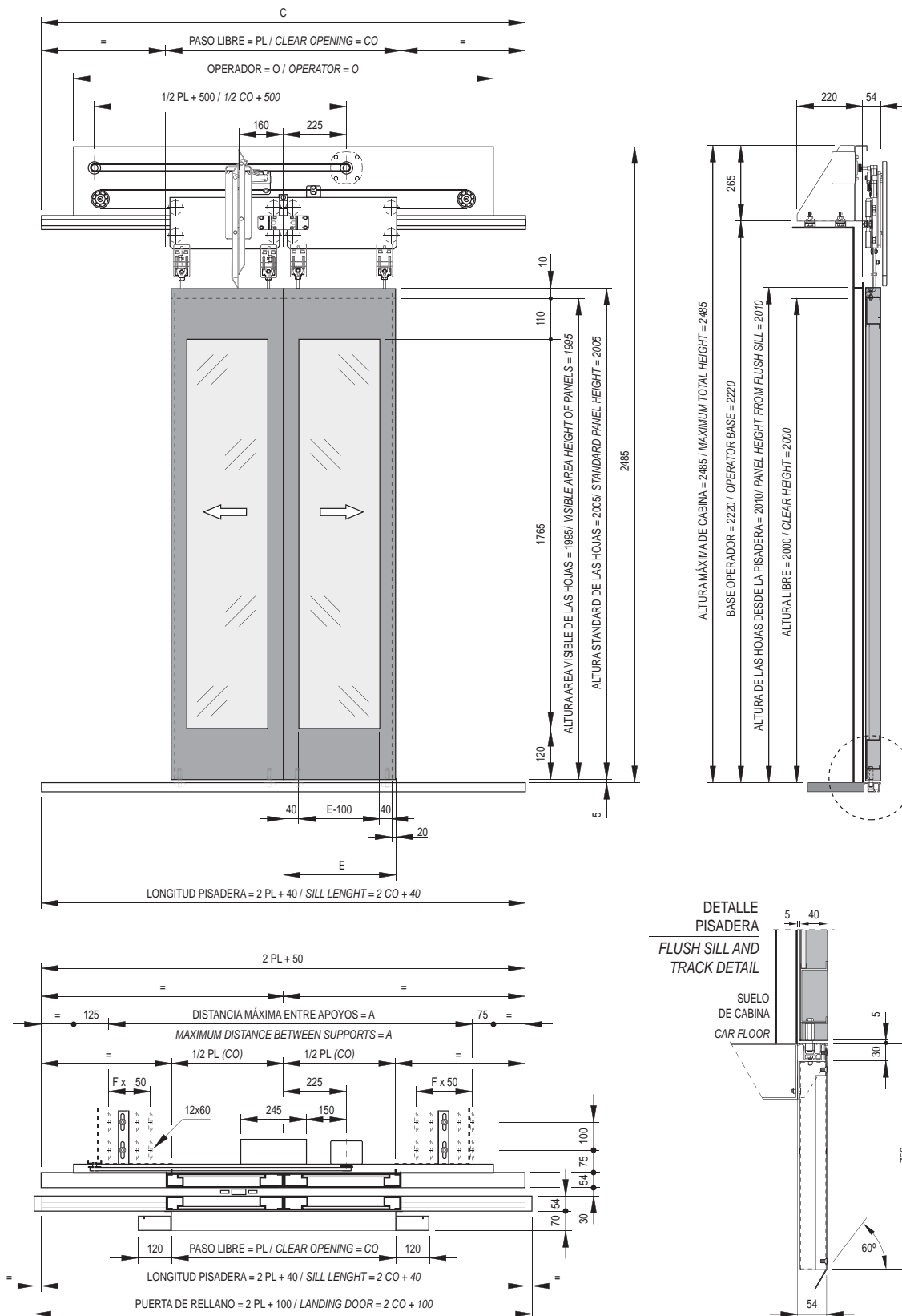

| PL / CO | 600 | 650 | 700 | 750 | 800 | 850 | 900 | 1000 | 1100 | 1200 |
|--------------------|------|------|------|------|------|------|------|------|------|------|
| A | 1000 | 1050 | 1200 | 1250 | 1300 | 1350 | 1400 | 1500 | 1600 | 2000 |
| C | 1250 | 1350 | 1450 | 1550 | 1650 | 1750 | 1850 | 2050 | 2250 | 2450 |
| O | 1200 | 1250 | 1400 | 1450 | 1500 | 1550 | 1600 | 1700 | 1800 | 2200 |
| E | 320 | 345 | 370 | 395 | 420 | 445 | 470 | 520 | 570 | 620 |
| F | 4 | 4 | 5 | 6 | 6 | 7 | 7 | 8 | 9 | 13 |
| PESO / WEIGHT (kg) | 72 | 78 | 84 | 90 | 96 | 101 | 107 | 119 | 131 | 143 |

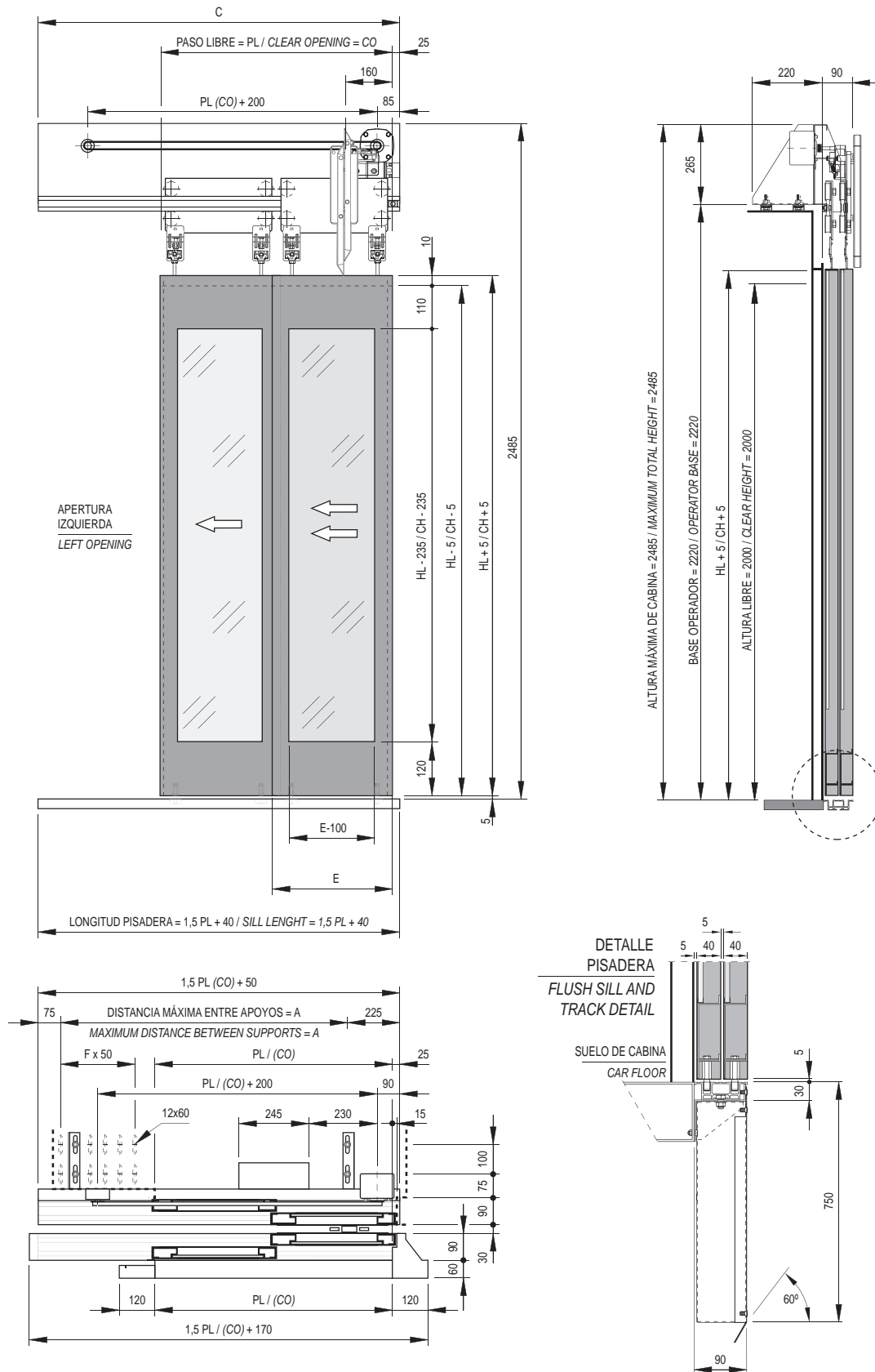

| PL / CO | 600 | 650 | 700 | 750 | 800 | 850 | 900 | 1000 | 1100 | 1200 |
|--------------------|-----|------|------|------|------|------|------|------|------|------|
| A | 650 | 725 | 800 | 875 | 950 | 1025 | 1100 | 1250 | 1400 | 1550 |
| C | 950 | 1025 | 1100 | 1175 | 1250 | 1325 | 1400 | 1550 | 1700 | 1850 |
| E | 320 | 345 | 370 | 395 | 420 | 445 | 470 | 520 | 570 | 620 |
| F | 4 | 4 | 5 | 5 | 6 | 6 | 6 | 7 | 8 | 8 |
| PESO / WEIGHT (kg) | 72 | 78 | 84 | 90 | 97 | 103 | 109 | 121 | 133 | 145 |

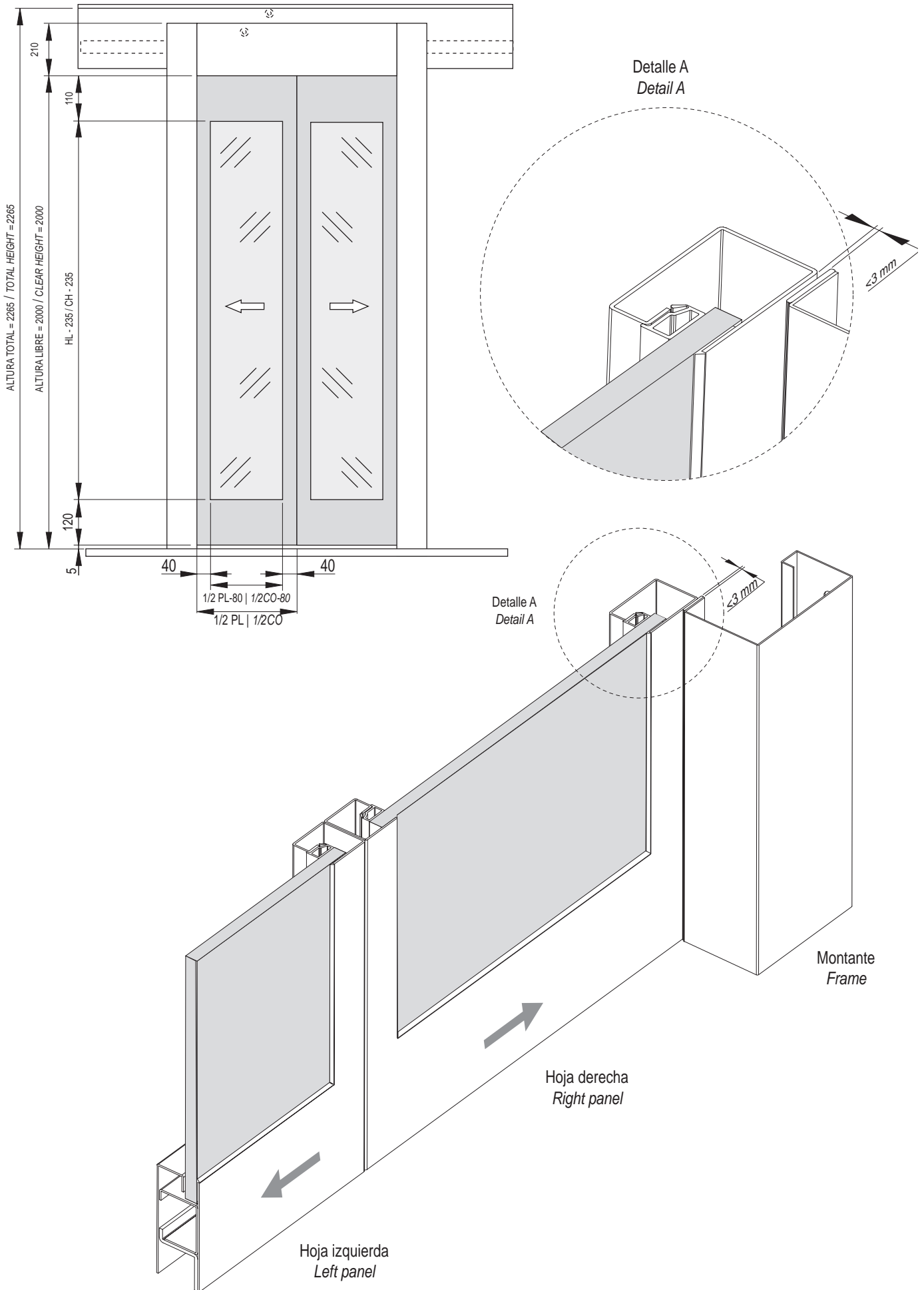

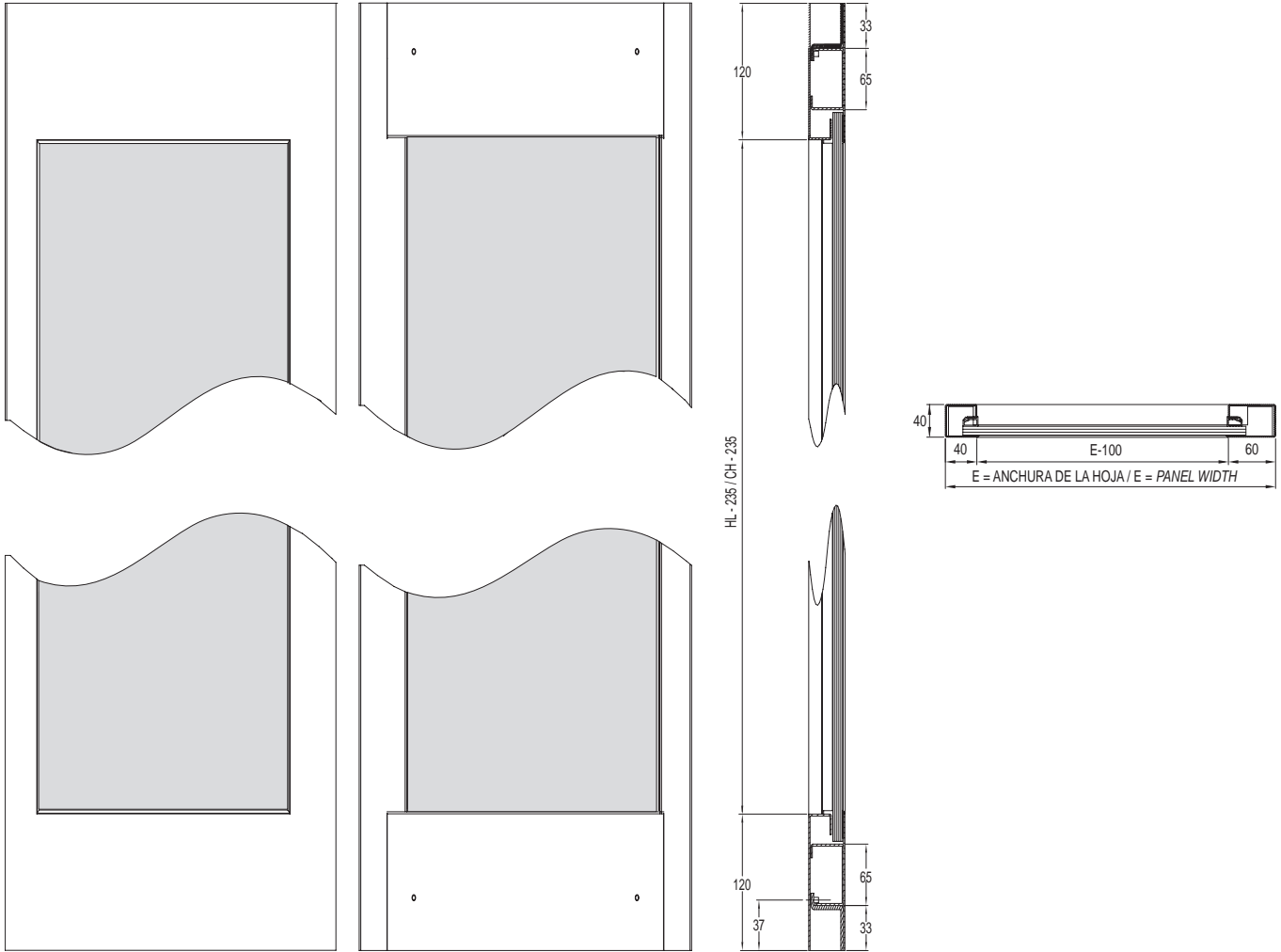

Detalle A
 Detalle A

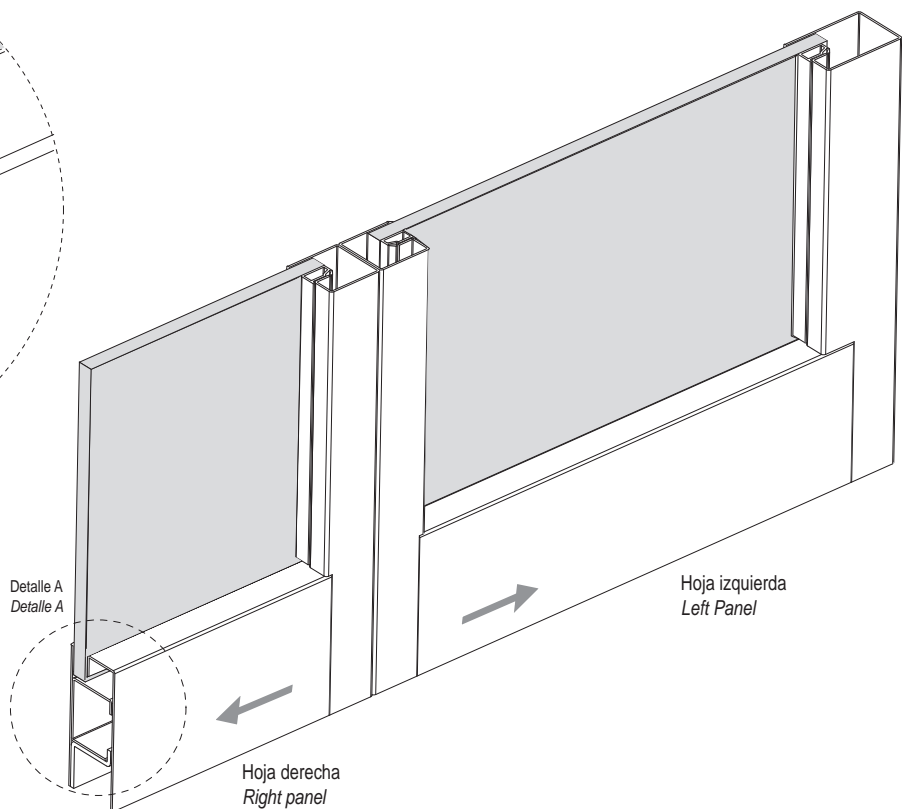
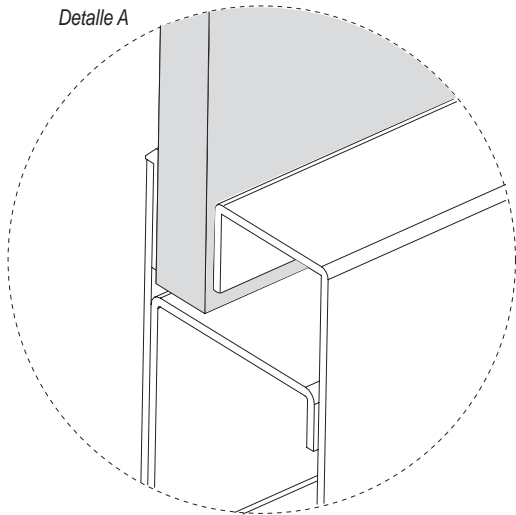

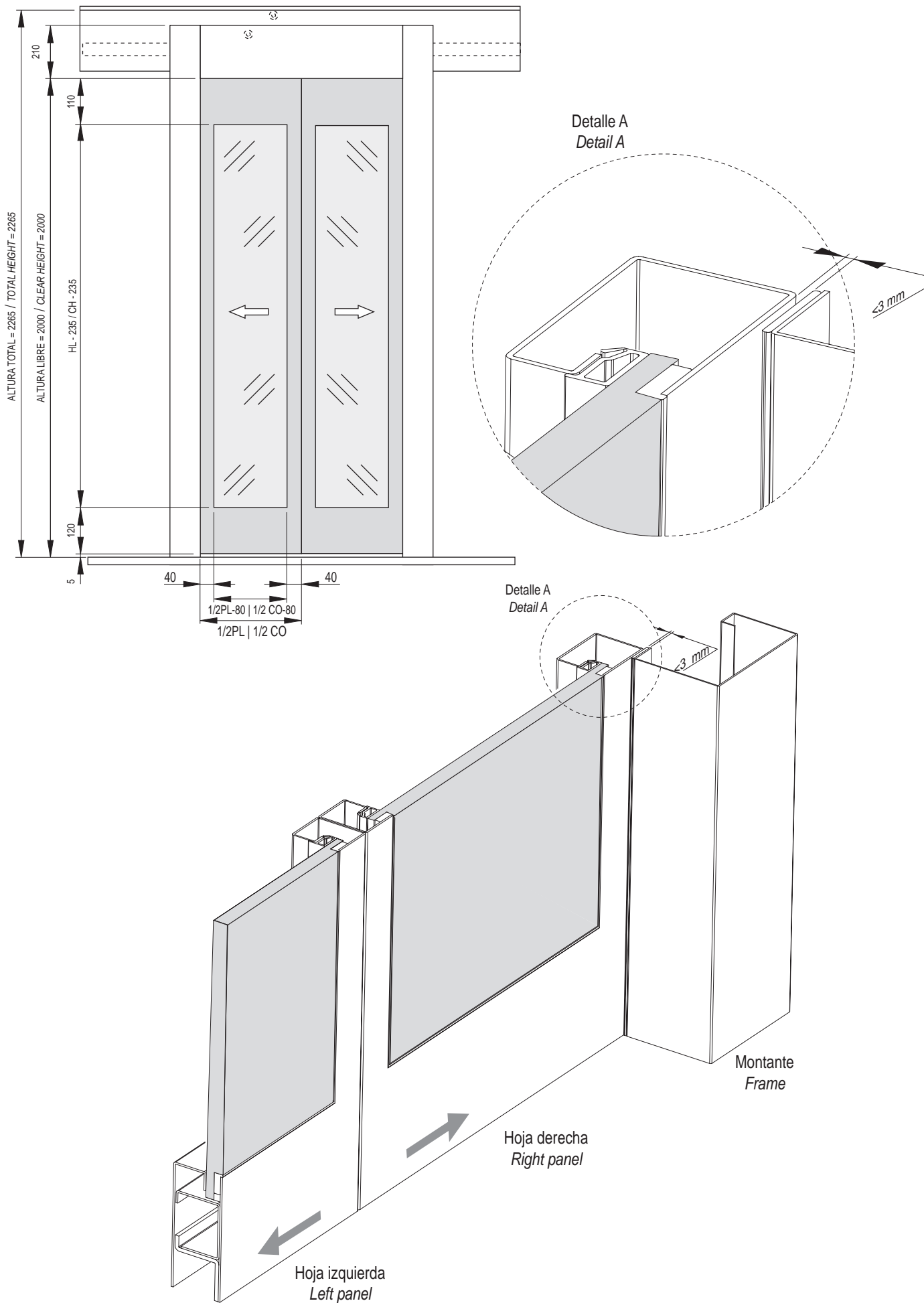

Ferमतo

AUTOMATIC DOORS FOR LIFTS

PUERTA DE RELLANO
SEMIAUTOMÁTICA
HINGED SEMIAUTOMATIC
LANDING DOOR

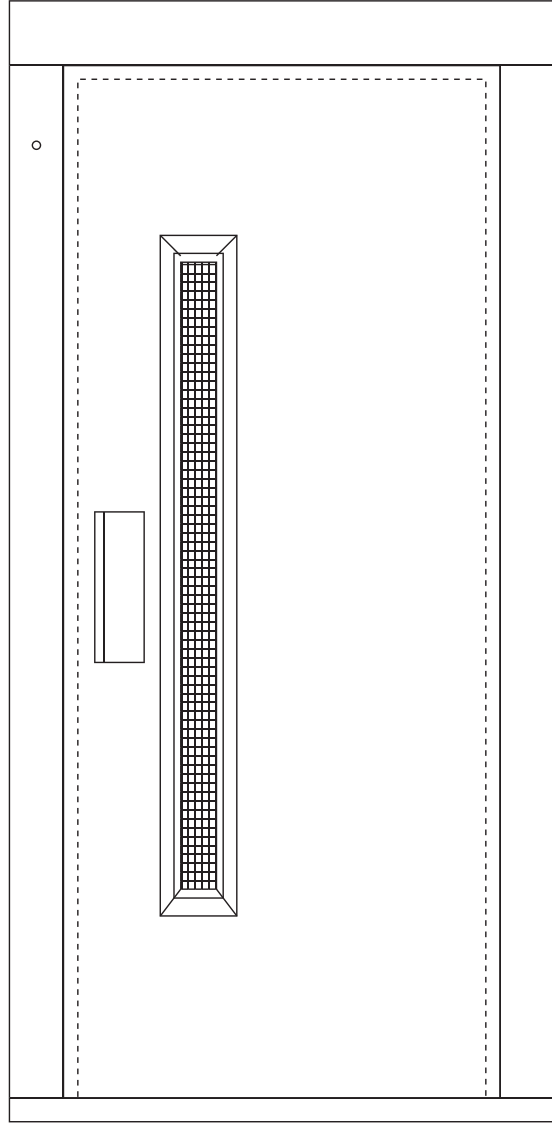

10

Puerta modelo «Fermator»
«Fermator» door type

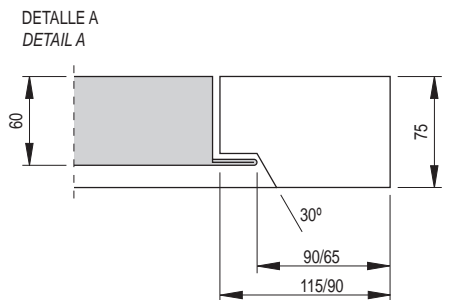
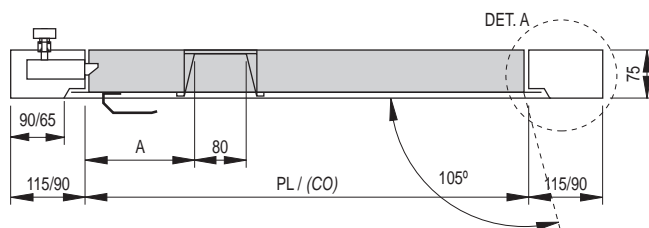
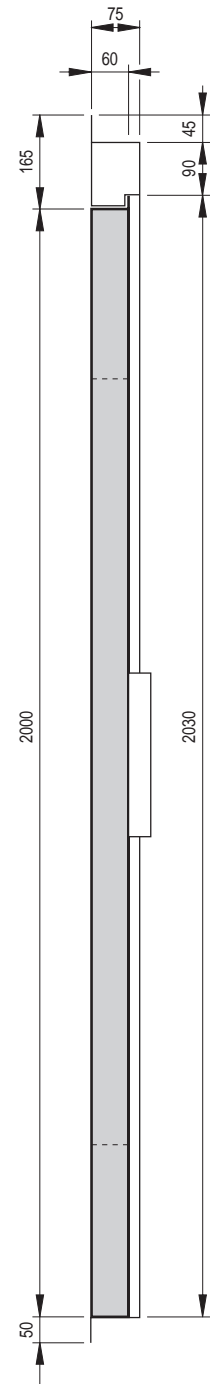
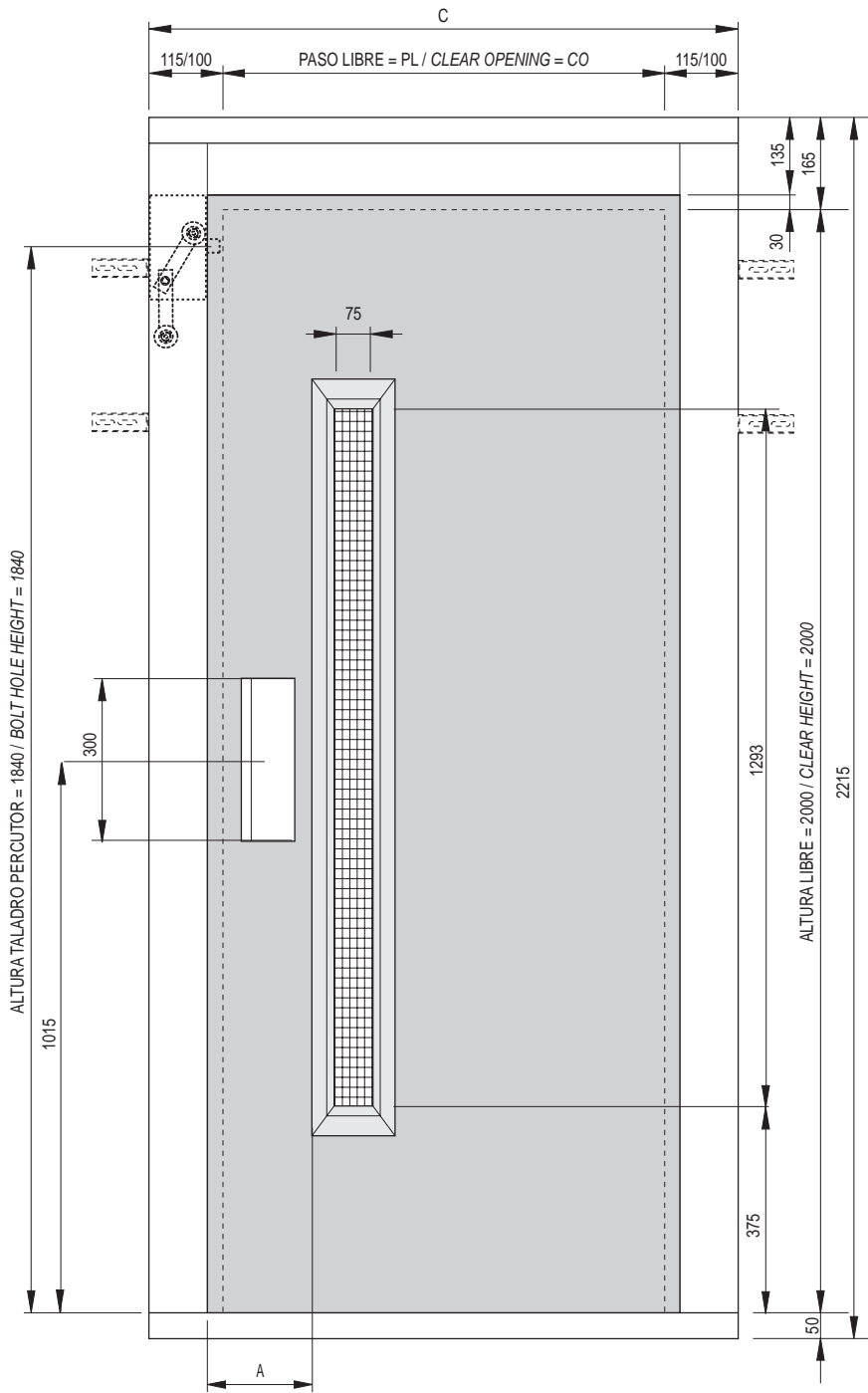

| PL / CO | 600 | 650 | 700 | 750 | 800 | 850 | 900 | 950 | 1000 |
|--------------------|-----|-----|-----|-----|------|------|------|------|------|
| A | 100 | 115 | 130 | 150 | 165 | 185 | 200 | 215 | 230 |
| C | 830 | 880 | 930 | 980 | 1030 | 1080 | 1130 | 1180 | 1230 |
| PESO / WEIGHT (kg) | 72 | 74 | 77 | 80 | 82 | 85 | 87 | 90 | 92 |

10.2.

PUERTA DE RELLANO SEMIAUTOMÁTICA SIN MIRILLA HINGED SEMI-AUTOMATIC LANDING DOOR WITHOUT VISION PANEL

Fermator
AUTOMATIC DOORS FOR LIFTS

Puerta modelo «Fermator»
«Fermator» door type

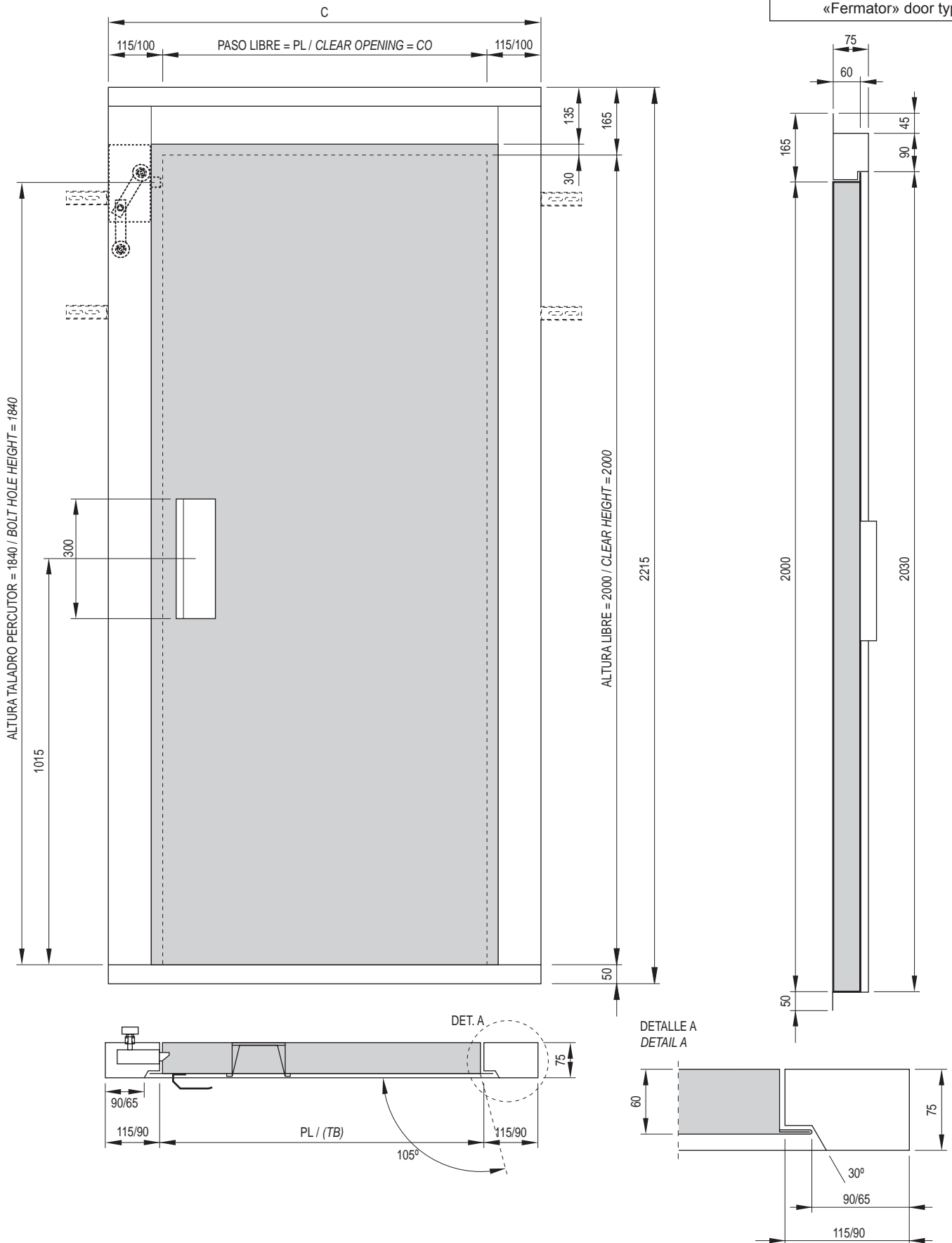

| PL / CO | 600 | 650 | 700 | 750 | 800 | 850 | 900 | 950 | 1000 |
|--------------------|-----|-----|-----|-----|------|------|------|------|------|
| C | 830 | 880 | 930 | 980 | 1030 | 1080 | 1130 | 1180 | 1230 |
| PESO / WEIGHT (kg) | 72 | 74 | 77 | 80 | 82 | 85 | 87 | 90 | 92 |

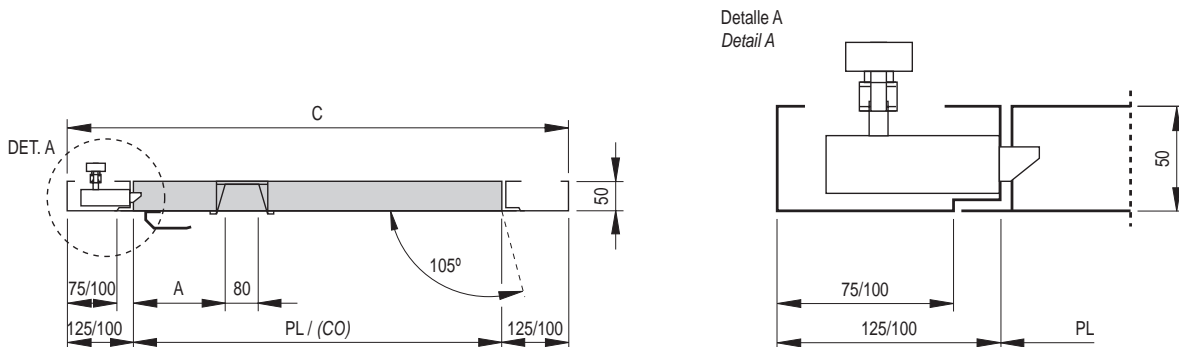
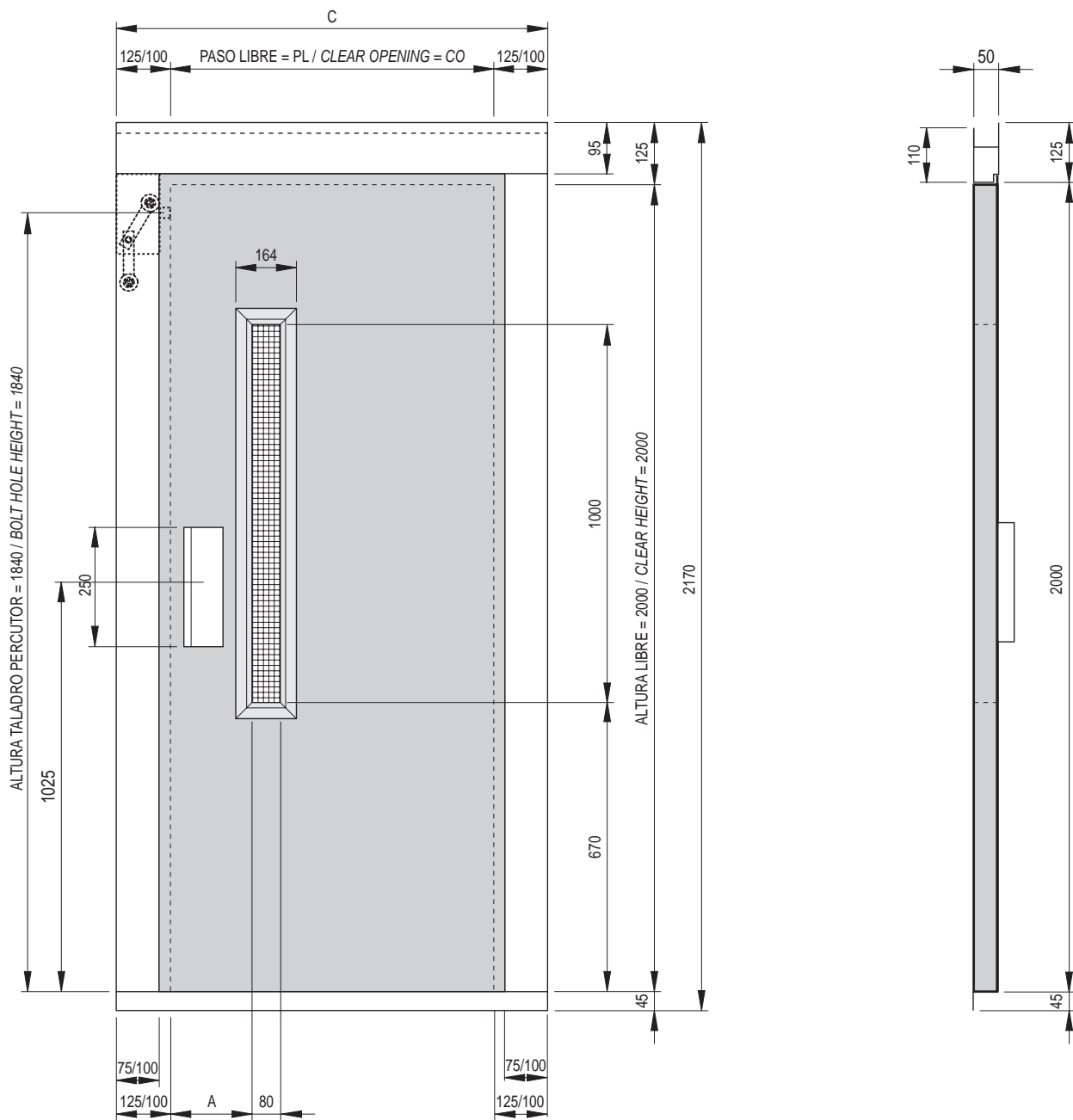

| | | PL / CO | 600 | 650 | 700 | 750 | 800 | 850 | 900 | 1000 |
|-----|--------------------|---------|-----|-----|-----|------|------|------|------|------|
| | A | | 130 | 140 | 155 | 165 | 180 | 190 | 205 | 220 |
| 125 | C | | 850 | 900 | 950 | 1000 | 1050 | 1100 | 1150 | 1250 |
| 100 | C | | 800 | 850 | 900 | 950 | 1000 | 1050 | 1100 | 1200 |
| | PESO / WEIGHT (kg) | | 46 | 49 | 51 | 54 | 56 | 59 | 61 | 64 |

10.4.

PUERTA DE RELLANO SEMIAUTOMÁTICA SIN MIRILLA HINGED SEMI-AUTOMATIC LANDING DOOR WITHOUT VISION PANEL

fermator
AUTOMATIC DOORS FOR LIFTS

Puerta modelo «Global»
«Global» door type

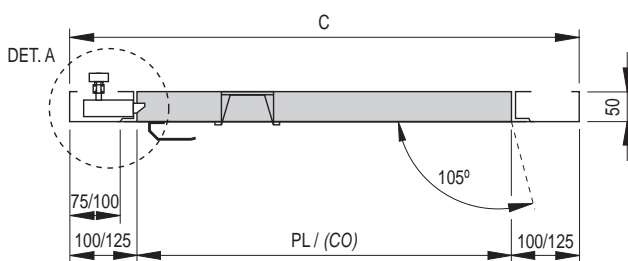
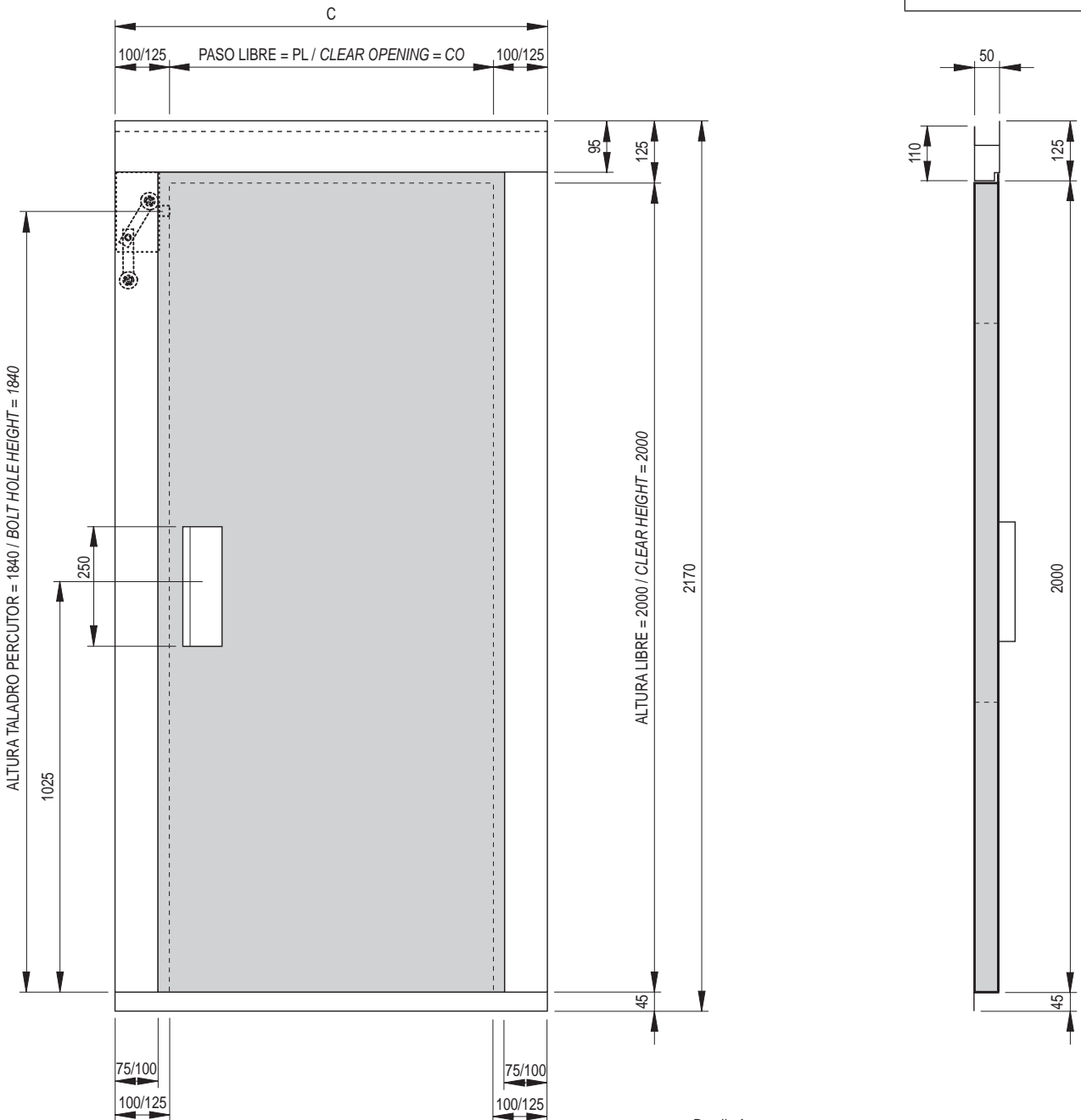

Detalle A
Detail A

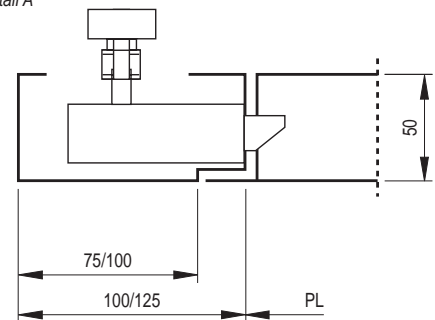

| | PL / CO | 600 | 650 | 700 | 750 | 800 | 850 | 900 | 950 | 1000 |
|-----|--------------------|-----|-----|-----|------|------|------|------|------|------|
| 125 | C | 850 | 900 | 950 | 1000 | 1050 | 1100 | 1150 | 1200 | 1250 |
| 100 | C | 800 | 850 | 900 | 950 | 1000 | 1050 | 1100 | 1150 | 1200 |
| | PESO / WEIGHT (kg) | 46 | 49 | 51 | 54 | 56 | 59 | 61 | 63 | 65 |

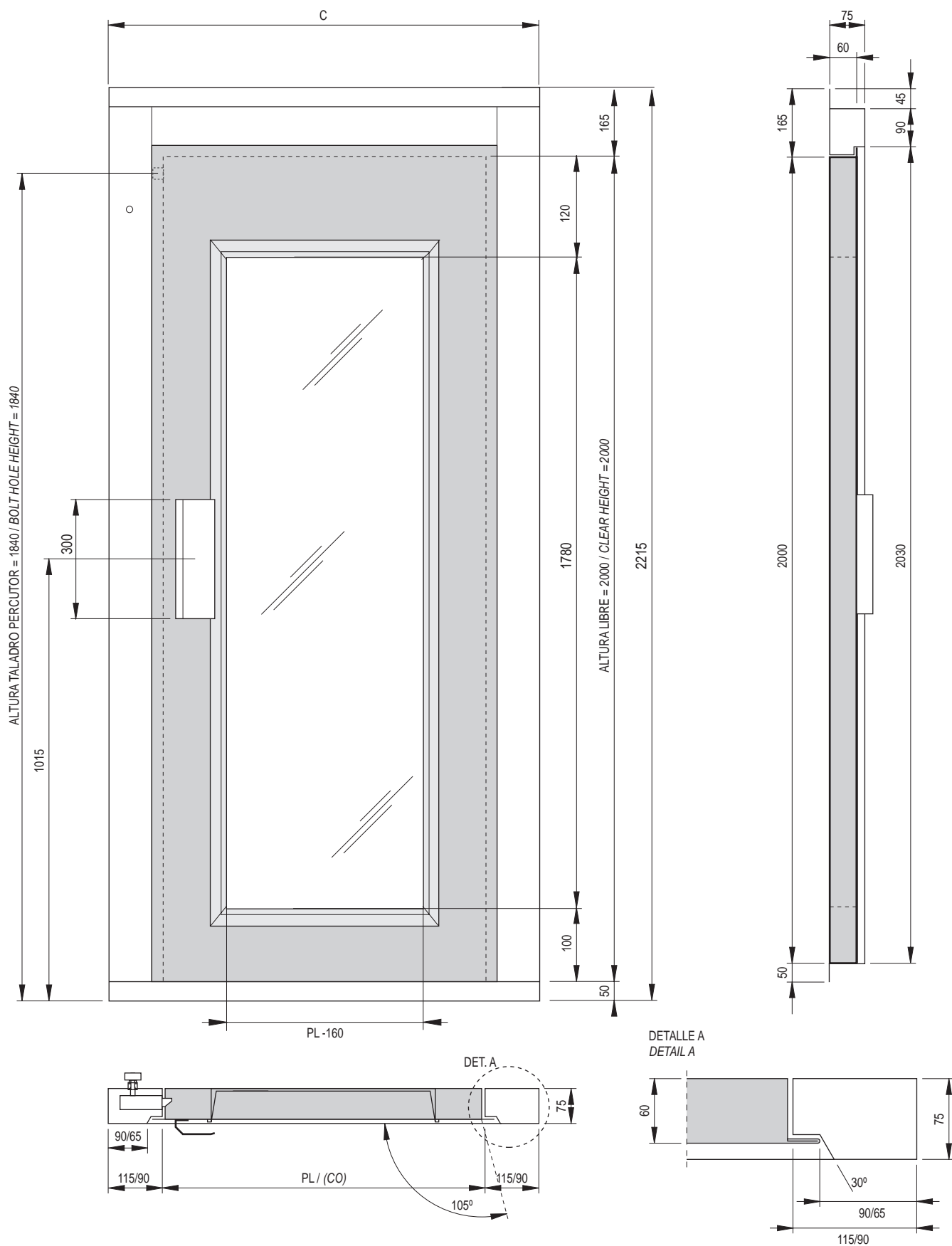

| | PL / CO | 600 | 650 | 700 | 750 | 800 | 850 | 900 | 950 | 1000 |
|-----|---------|-----|-----|-----|-----|------|------|------|------|------|
| 115 | C | 830 | 880 | 930 | 980 | 1030 | 1080 | 1130 | 1180 | 1230 |
| 90 | C | 780 | 830 | 880 | 930 | 980 | 1030 | 1080 | 1130 | 1180 |

Ferrotec

AUTOMATIC DOORS FOR LIFTS

PUERTAS PLEGABLES
AUTOMATIC FOLDING DOORS

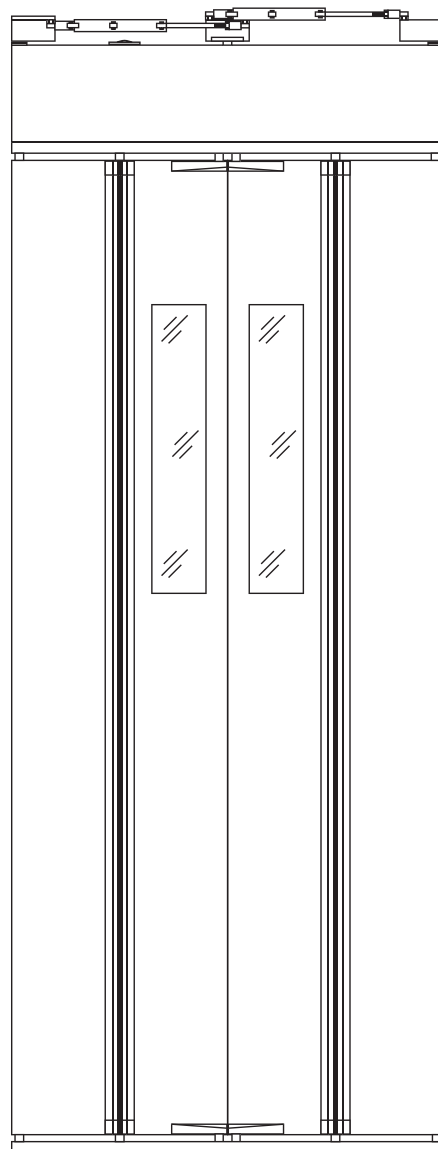

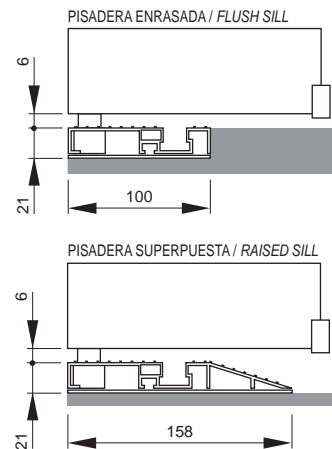
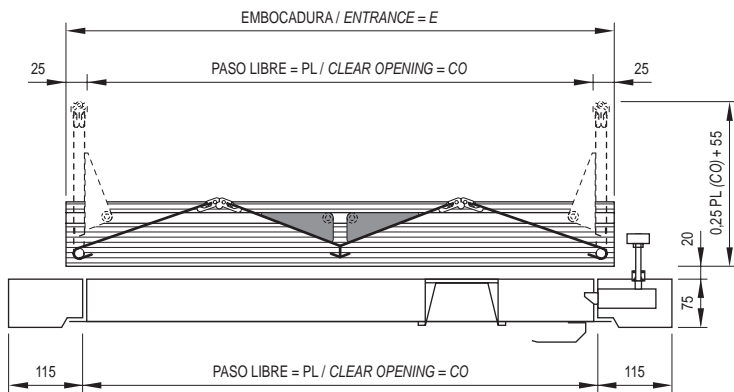
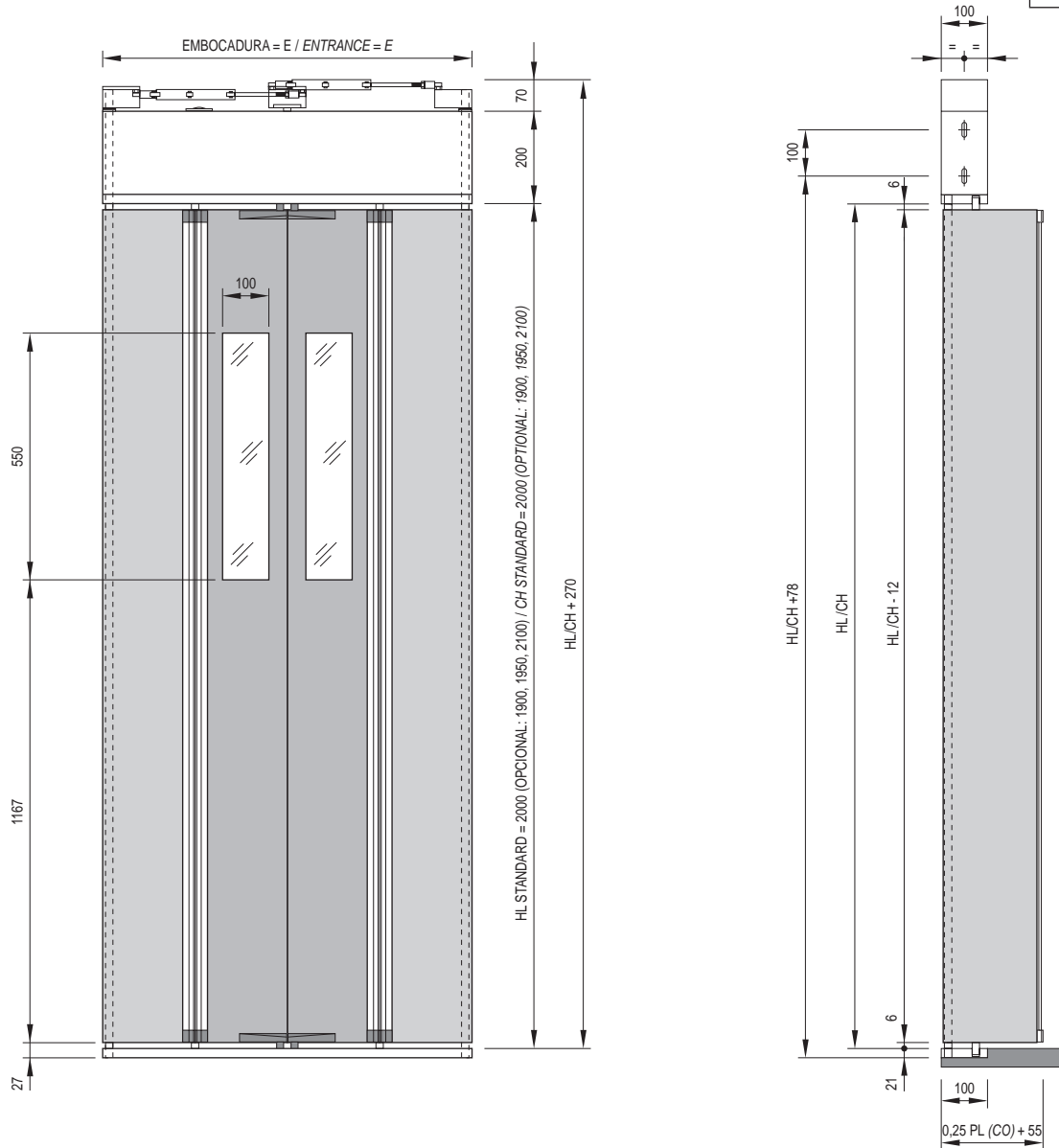

| PL / CO | 500 | 550 | 600 | 650 | 700 | 750 | 800 | 850 | 900 | 950 | 1000 | 1050 | 1100 | 1150 | |
|--------------------|-----|-----|-----|-----|-----|-----|-----|-----|-----|------|------|------|------|------|--|
| E | 550 | 600 | 650 | 700 | 750 | 800 | 850 | 900 | 950 | 1000 | 1050 | 1100 | 1150 | 1200 | |
| TIEMPO / TIME (s) | 2,8 | | | | | 3,4 | | | | 3,7 | | | 3,9 | | |
| PESO / WEIGHT (kg) | 35 | 39 | 41 | 43 | 46 | 48 | 50 | 52 | 54 | 56 | 58 | 60 | 62 | 64 | |

- OPCIONAL: OPERADOR PLEGABLE DE CABINA MODELO "G"
OPTIONAL: FOLDING CAR OPERATOR MODEL "G"

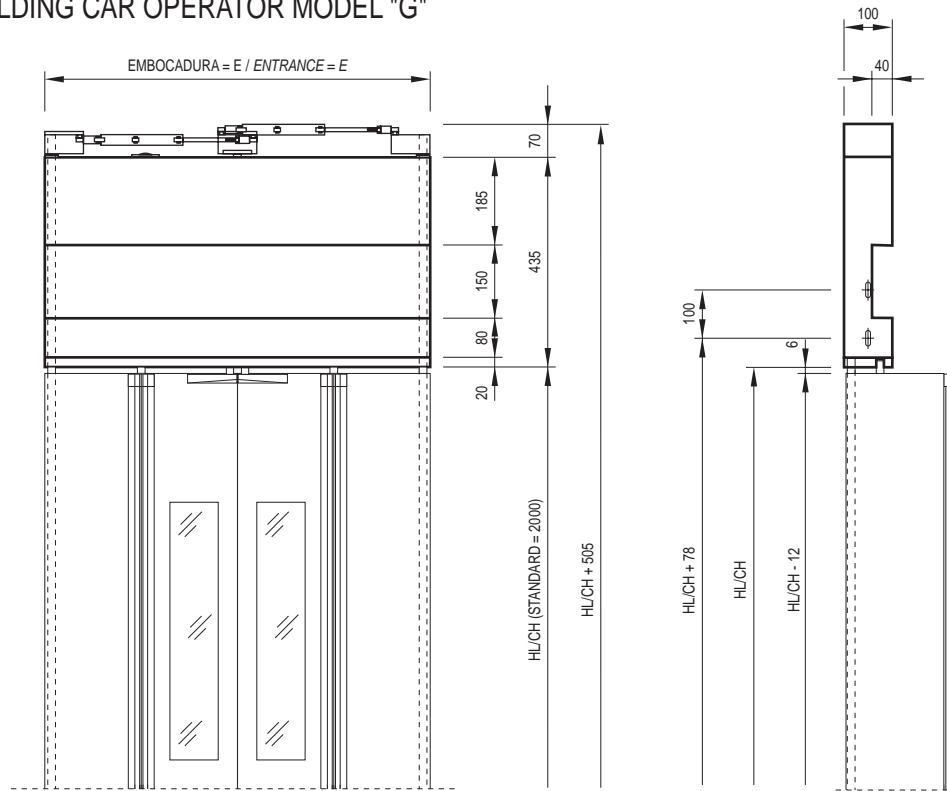

- OPCIONAL: OPERADOR PLEGABLE DE CABINA MODELO "O"
OPTIONAL: FOLDING CAR OPERATOR MODEL "O"

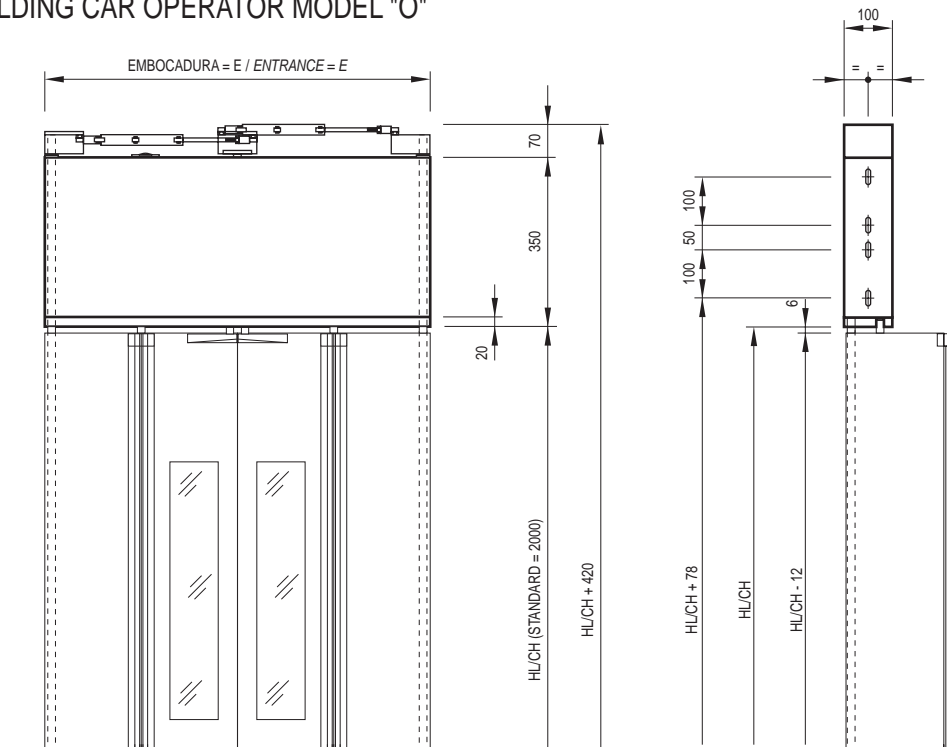

| PL / CO | 500 | 550 | 600 | 610 | 630 | 650 | 670 | 700 | 750 | 800 | 850 | 900 | 950 | 1000 | 1050 | 1100 | 1150 |
|--------------------|-----|-----|-----|-----|-----|-----|-----|-----|-----|-----|-----|-----|------|------|------|------|------|
| E | 550 | 600 | 650 | 660 | 680 | 700 | 720 | 750 | 800 | 850 | 900 | 950 | 1000 | 1050 | 1100 | 1150 | 1200 |
| TIEMPO / TIME (s) | 2,8 | | | | | | | | 3,4 | | | 3,7 | | | 3,9 | | |
| PESO / WEIGHT (kg) | 35 | 39 | 41 | 41 | 42 | 43 | 44 | 46 | 48 | 50 | 52 | 54 | 56 | 58 | 60 | 62 | 64 |

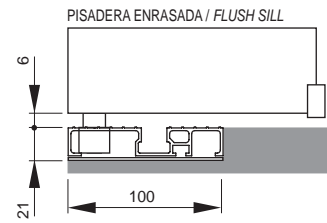
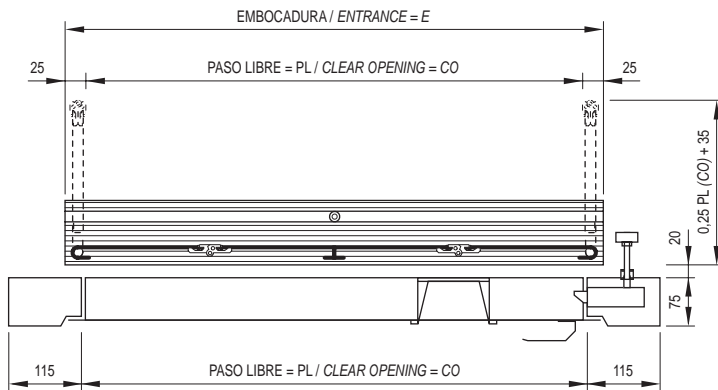
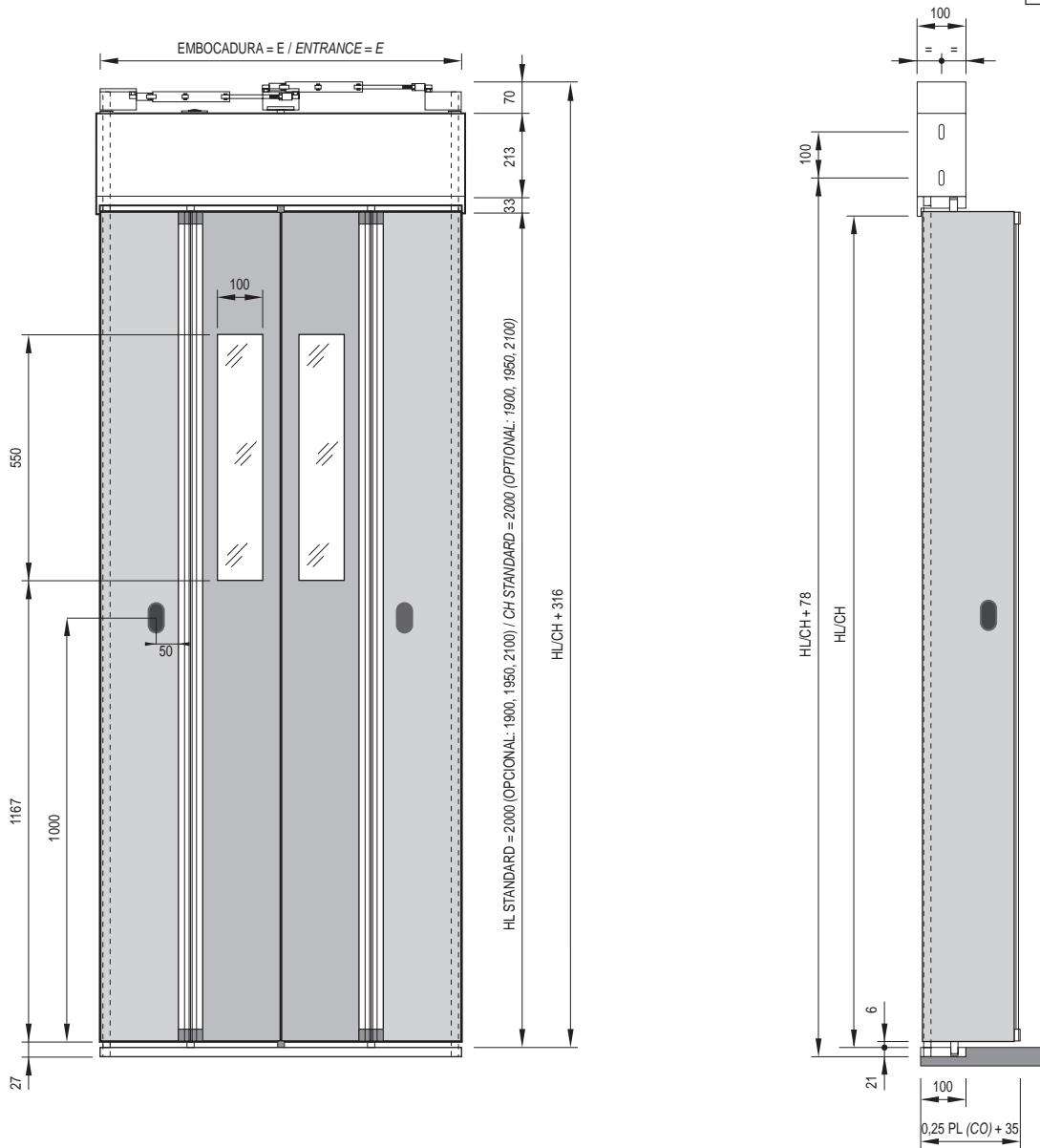

| PL / CO | 500 | 550 | 600 | 610 | 630 | 650 | 670 | 700 | 750 | 800 | 850 | 900 | 950 | 1000 | 1050 | 1100 | 1150 |
|--------------------|-----|-----|-----|-----|-----|-----|-----|-----|-----|-----|-----|-----|------|------|------|------|------|
| E | 550 | 600 | 650 | 660 | 680 | 700 | 720 | 750 | 800 | 850 | 900 | 950 | 1000 | 1050 | 1100 | 1150 | 1200 |
| TIEMPO / TIME (s) | 2,8 | | | | | | | | 3,4 | | | 3,7 | | | 3,9 | | |
| PESO / WEIGHT (kg) | 35 | 39 | 41 | 41 | 42 | 43 | 44 | 46 | 48 | 50 | 52 | 54 | 56 | 58 | 60 | 62 | 64 |

11.4.

PUERTA DE CABINA PLEGABLE MODELO ECC PLANO FOLDING CAR DOOR ECC FLAT MODEL

Fermator
AUTOMATIC DOORS FOR LIFTS

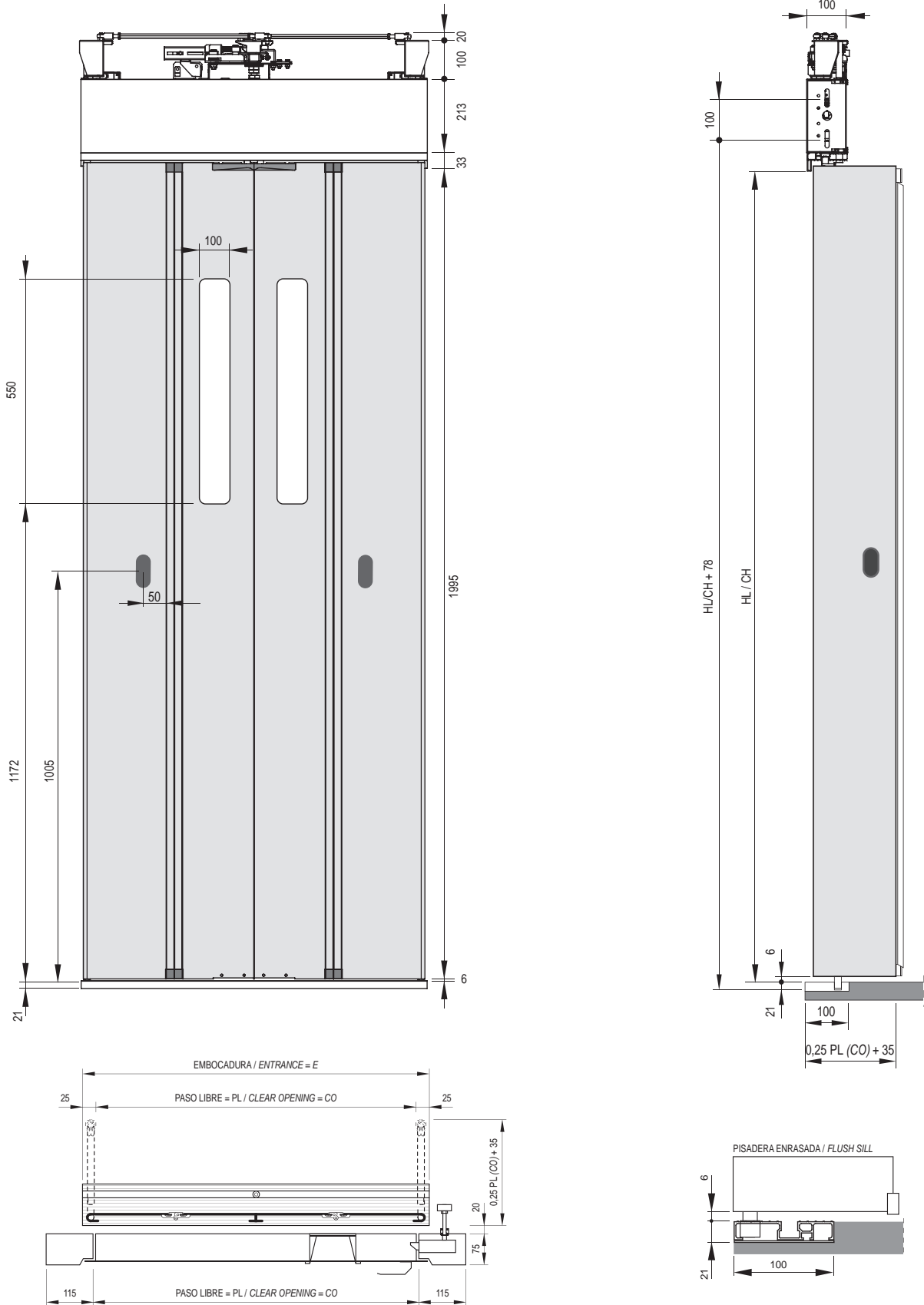

| PL / CO | 500 | 550 | 600 | 610 | 630 | 650 | 670 | 700 | 750 | 800 | 850 | 900 | 950 | 1000 | 1050 | 1100 | 1150 |
|--------------------|-----|-----|-----|-----|-----|-----|-----|-----|-----|-----|-----|-----|------|------|------|------|------|
| E | 550 | 600 | 650 | 660 | 680 | 700 | 720 | 750 | 800 | 850 | 900 | 950 | 1000 | 1050 | 1100 | 1150 | 1200 |
| TIEMPO / TIME (s) | 2,8 | | | | | | | | 3,4 | | | 3,7 | | | 3,9 | | |
| PESO / WEIGHT (kg) | 35 | 39 | 41 | 41 | 42 | 43 | 44 | 46 | 48 | 50 | 52 | 54 | 56 | 58 | 60 | 62 | 64 |

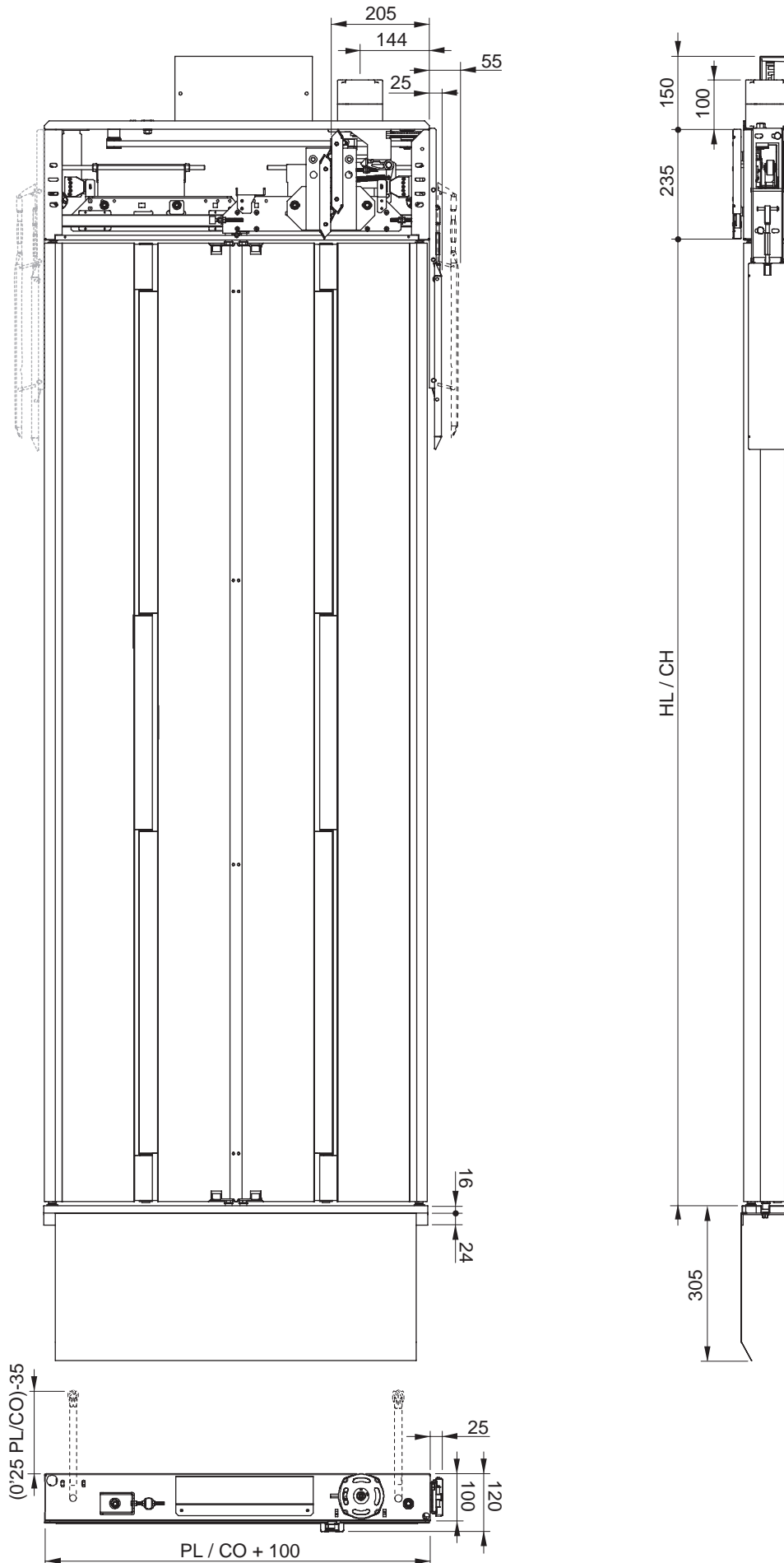

11.6.

PUERTA DE RELLANO PLEGABLE MODELO LB FOLDING LANDING DOOR LB MODEL

fermator
AUTOMATIC DOORS FOR LIFTS

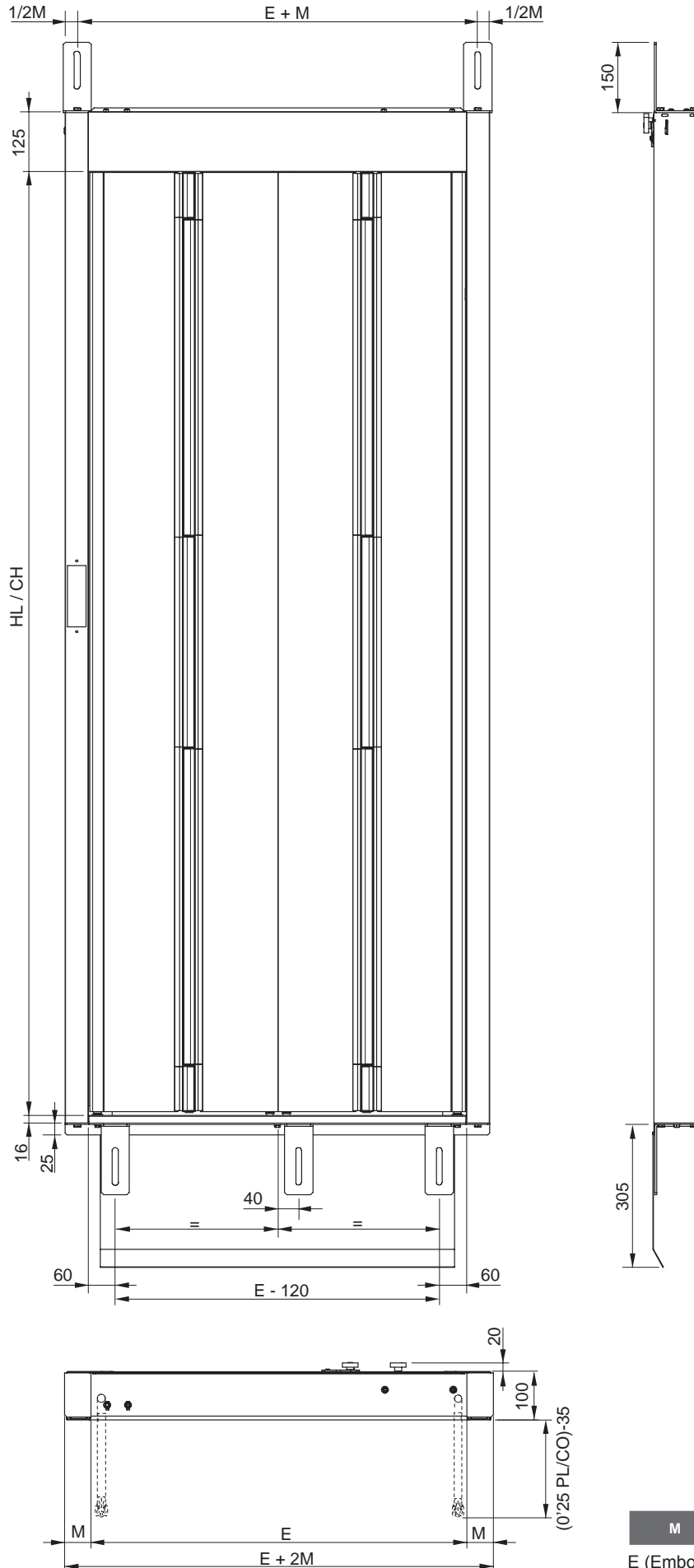

| M | 50 | 65 | 100 |
|---|----|----|-----|
|---|----|----|-----|

E (Embocadura/Entrance) = PL/CO + 100

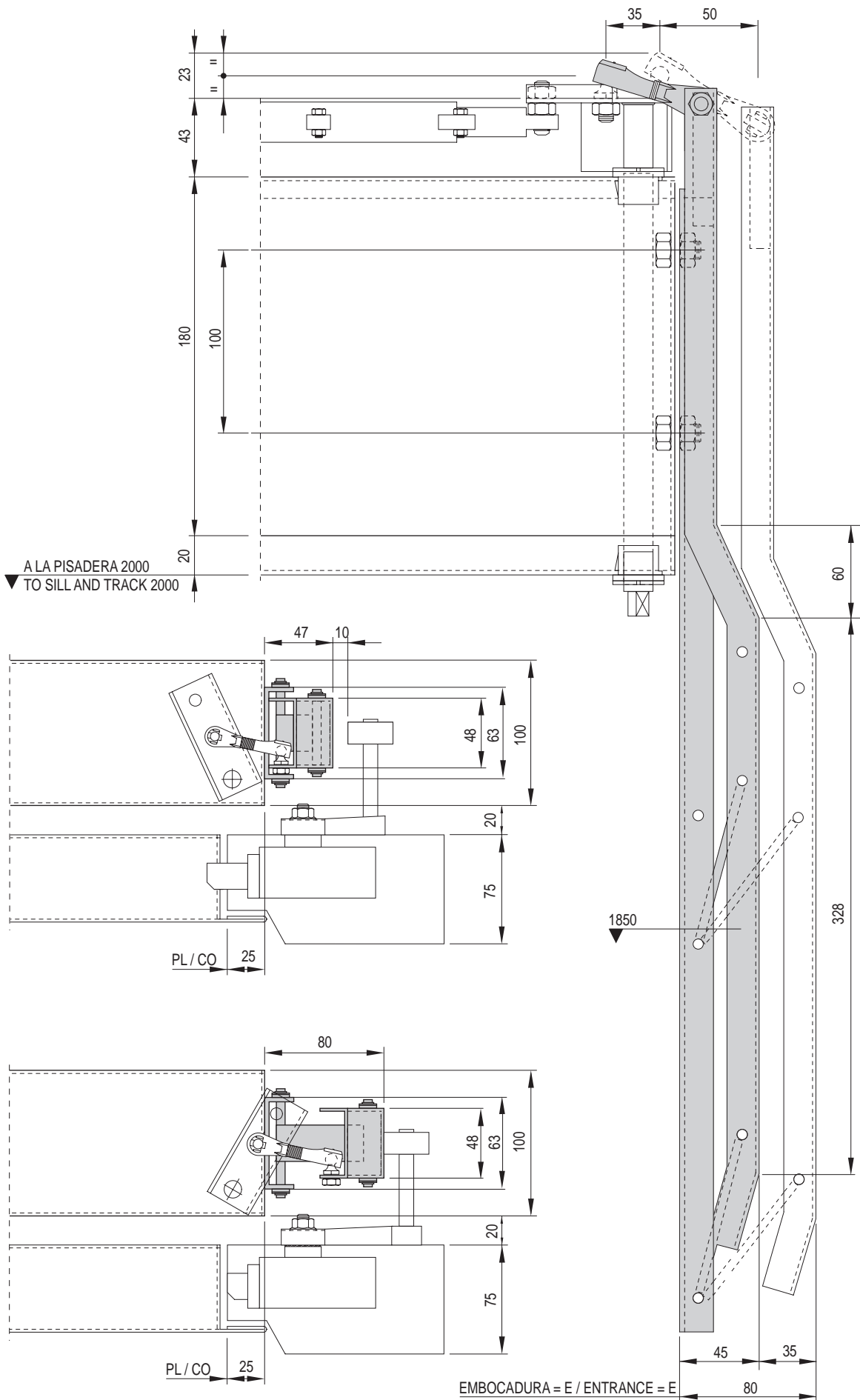

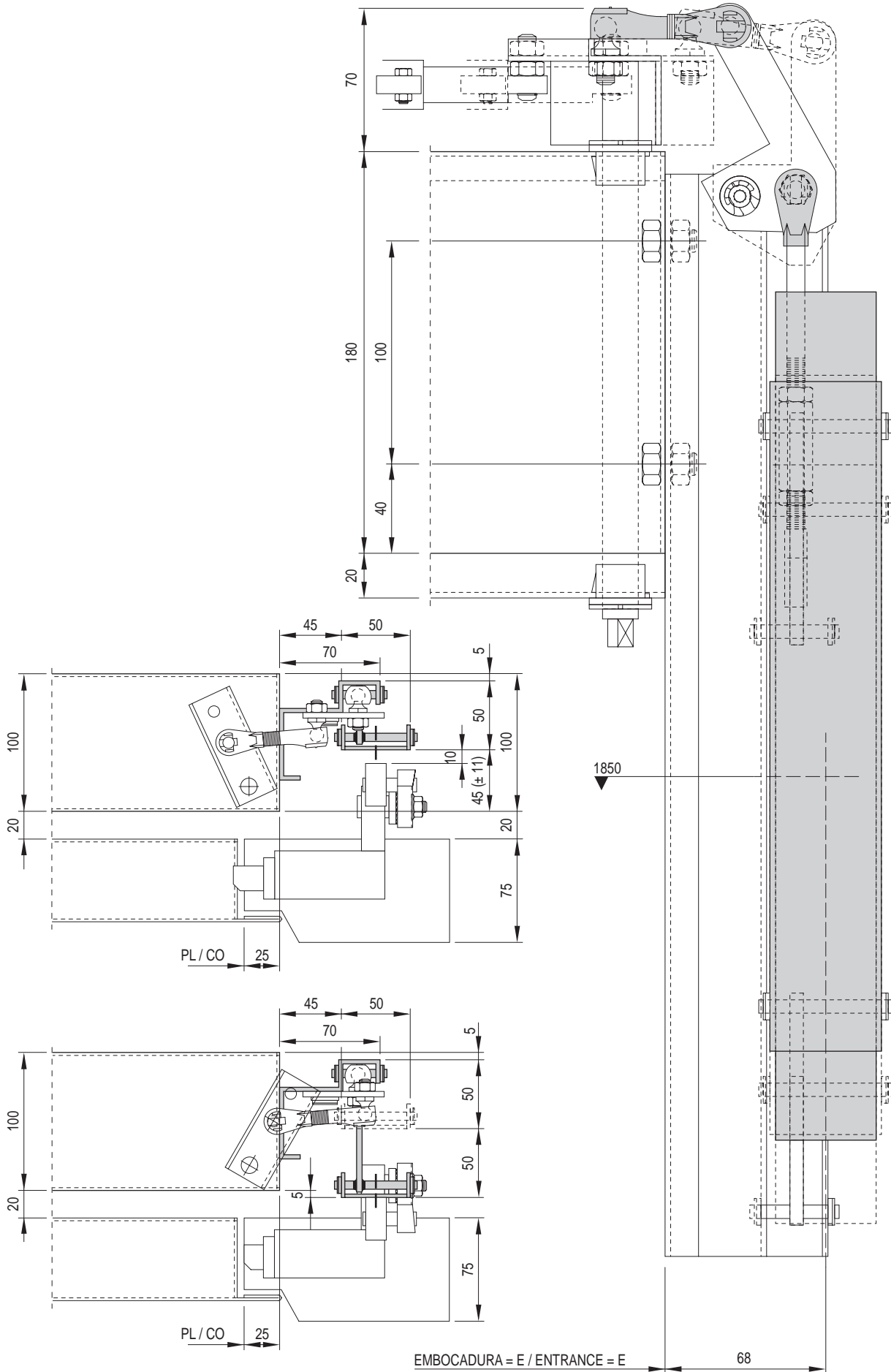

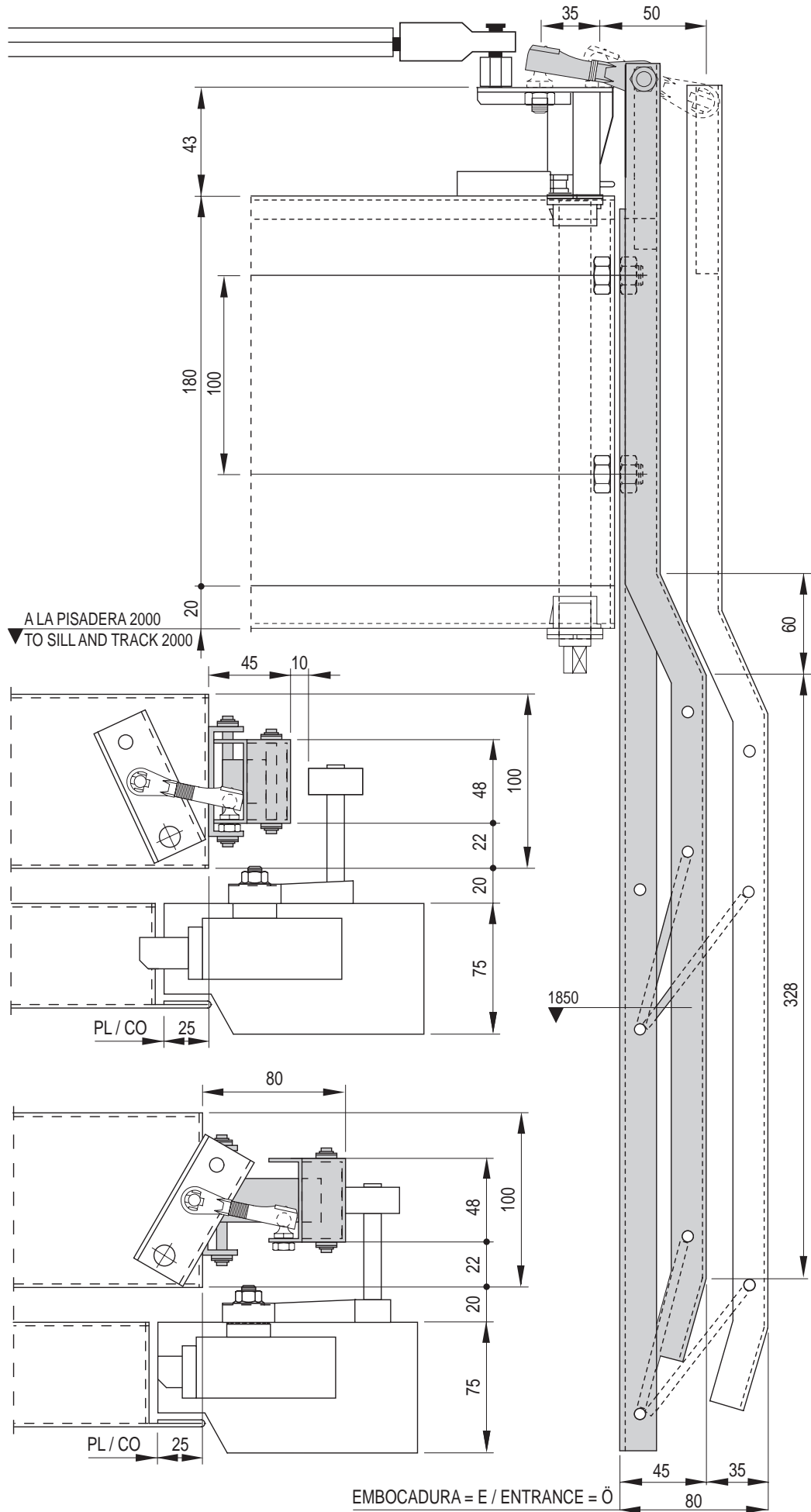

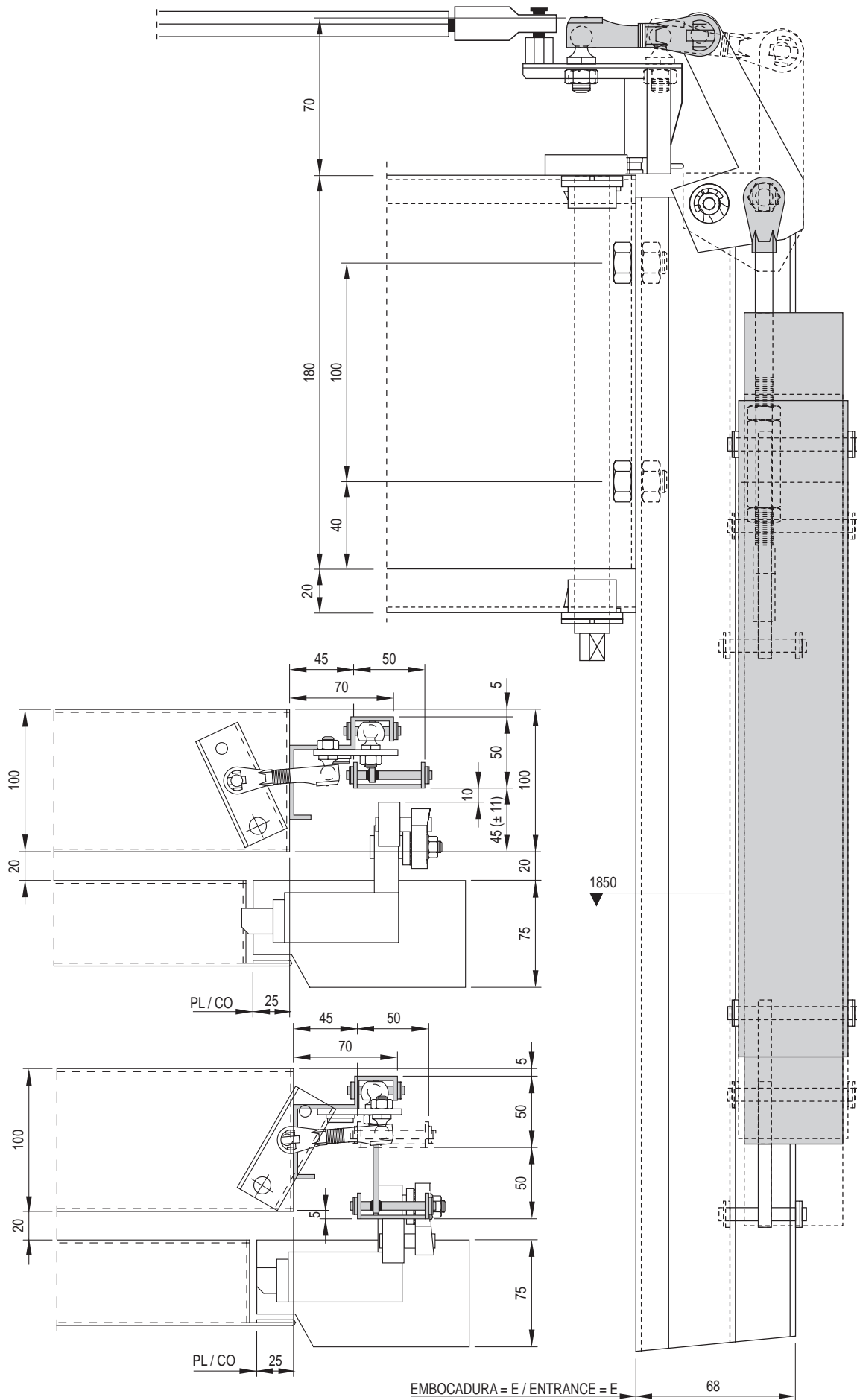

Ferrotec

AUTOMATIC DOORS FOR LIFTS

PUERTAS PARA REFORMAS
SPECIAL DOORS FOR MODERNIZATION

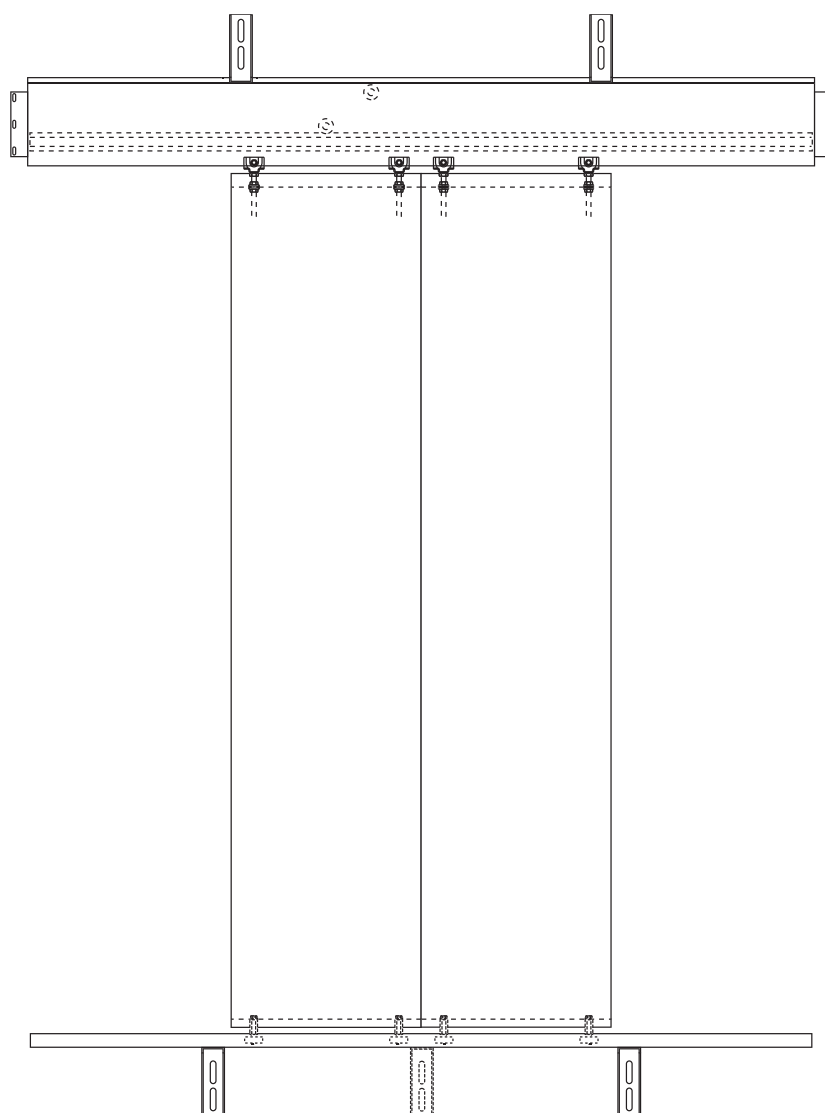

Puerta de rellano sin cerco, especial para reformas
Landing door without frames, for modernization

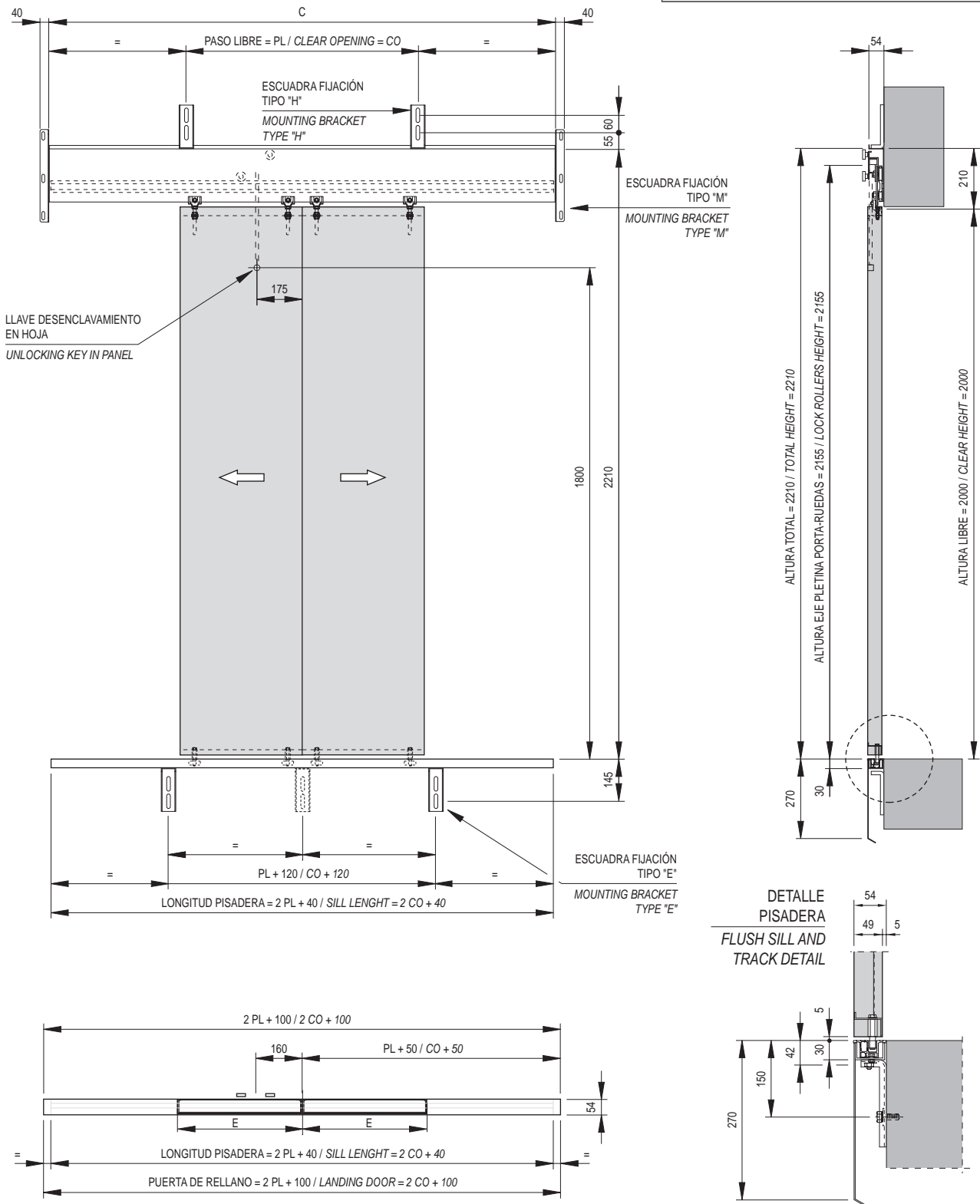

| Tipo de escuadra Bracket type | Cantidad Quantity | |
|----------------------------------|----------------------|---------|
| M | 2 | 2 |
| H | 2 | 3 |
| E | 3 | 5 |
| PL / CO | <= 1000 | >= 1100 |

| PL / CO | 600 | 650 | 700 | 750 | 800 | 850 | 900 | 1000 | 1100 | 1200 | 1300 | 1400 | 1500 | 1600 |
|---------|------|------|------|------|------|------|------|------|------|------|------|------|------|------|
| C | 1300 | 1400 | 1500 | 1600 | 1700 | 1800 | 1900 | 2100 | 2300 | 2500 | 2700 | 2900 | 3100 | 3300 |
| E | 320 | 345 | 370 | 395 | 420 | 445 | 470 | 520 | 570 | 620 | 670 | 720 | 770 | 820 |

Con puerta de rellano automática y pisadera de 70mm
With automatic landing door and flush sill of 70mm

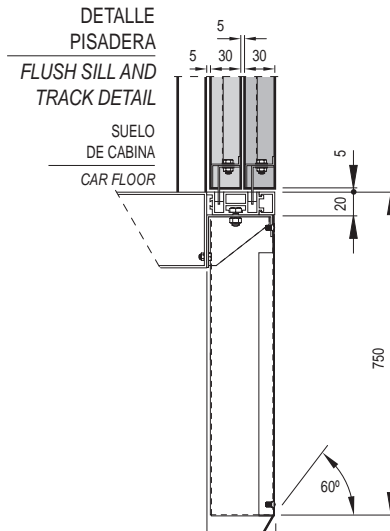
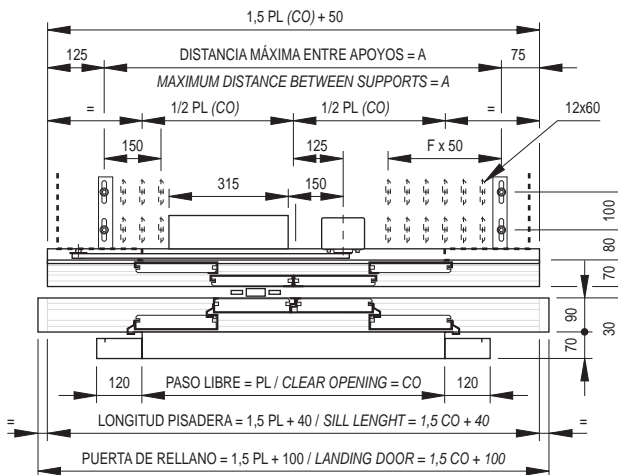
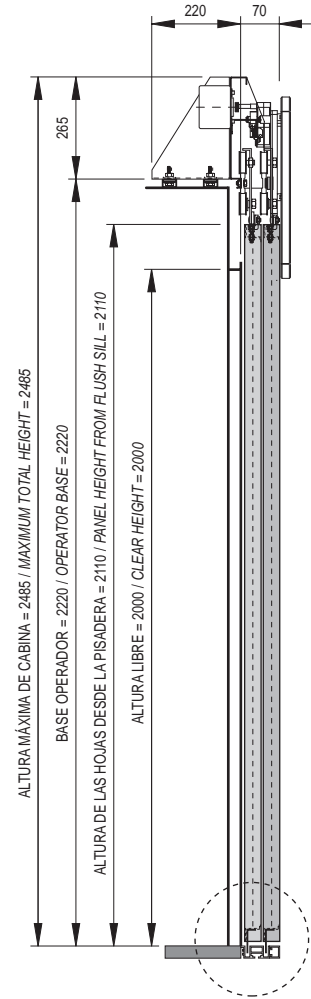
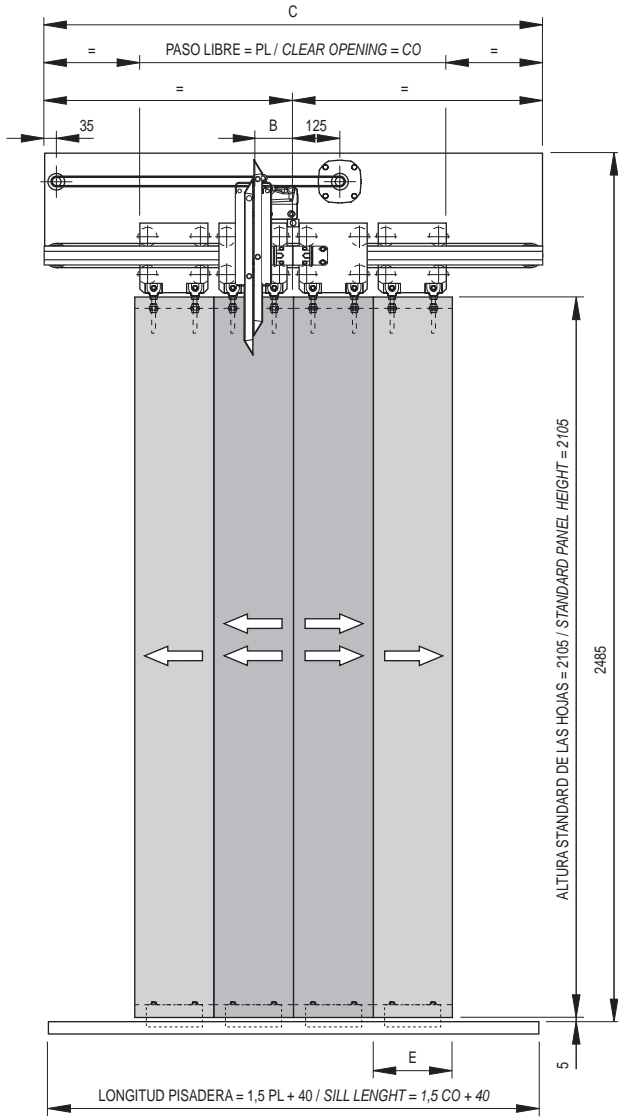

| PL / CO | 600 | 650 | 700 | 750 | 800 | 900 | 1000 |
|--------------------|------|-------|------|-------|------|------|-------|
| A | 750 | 825 | 900 | 975 | 1050 | 1200 | 1350 |
| B | 100 | 100 | 100 | 100 | 100 | 100 | 160 |
| C | 980 | 1025 | 1100 | 1175 | 1250 | 1400 | 1550 |
| E | 170 | 182,5 | 195 | 207,5 | 220 | 245 | 270 |
| F | 4 | 4 | 5 | 5 | 6 | 6 | 7 |
| TIEMPO / TIME (s) | 1,22 | 1,27 | 1,32 | 1,37 | 1,41 | 1,5 | 1,58 |
| PESO / WEIGHT (kg) | 61,5 | 67 | 72 | 77 | 82 | 92,5 | 102,5 |

PL 700, con puerta de rellano semiautomática y pisadera de 70mm
CO 700, with hinged semi-automatic landing door and flush sill of 70mm

*OPCIONAL: MIRILLAS PUERTA / OPTION: VISION PANEL

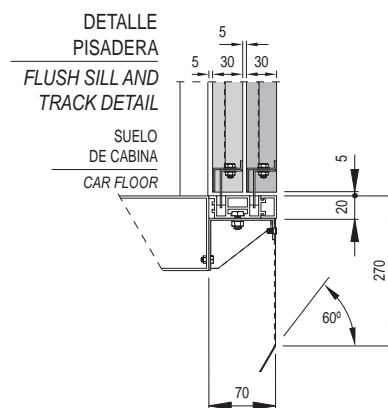
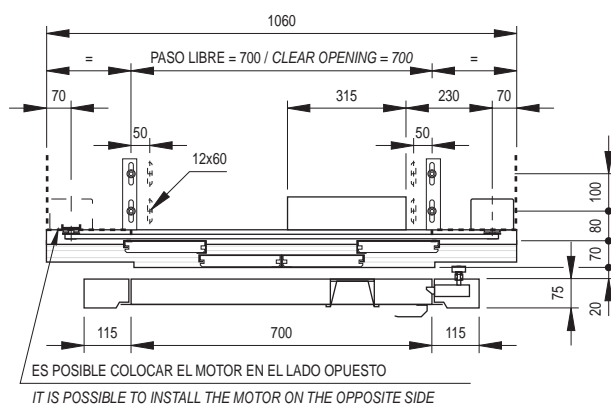
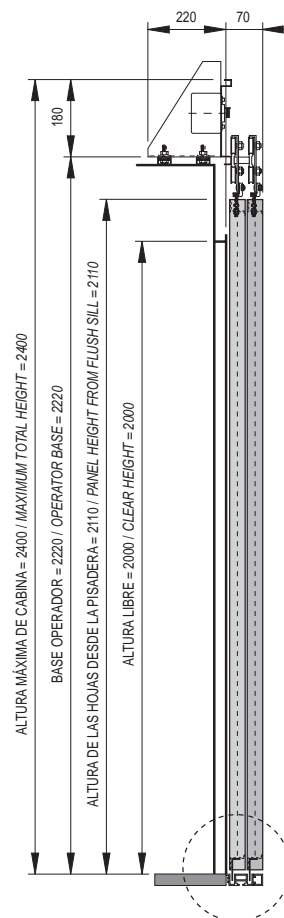
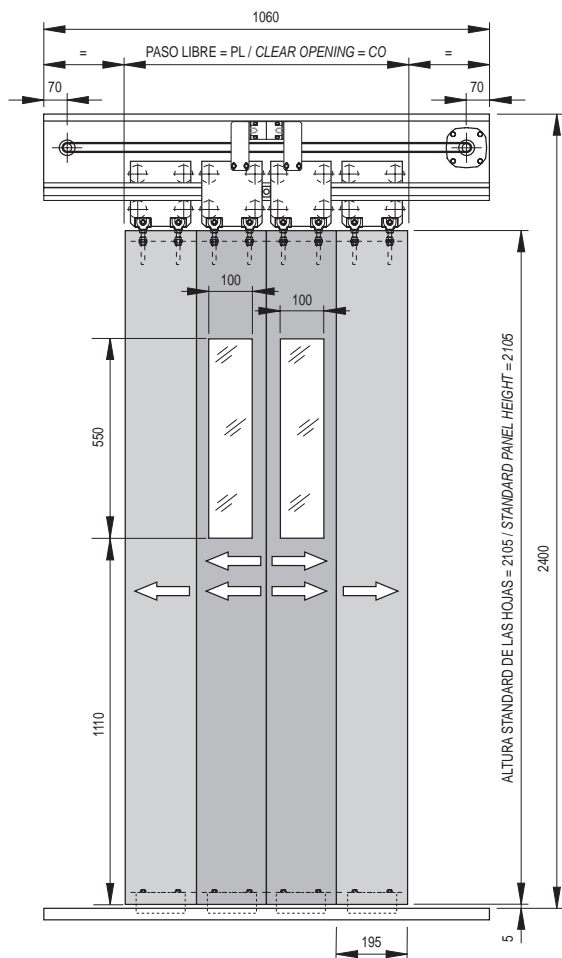

CARACTERÍSTICAS TÉCNICAS:

- Circuito con regulación de velocidad mediante variación de frecuencia incorporado.
- Accionamiento mediante señal de leva a cualquier tensión desde 12v-24v AC o DC.
- Alimentación 220v. alterna monofásica.
- Velocidad de apertura regulable hasta 1000 mm/s.
- Velocidad de cierre regulable hasta 600 mm/s.
- Esfuerzo contra obstáculo regulable de 4 a 12 Kgs.
- Peso en acabado inox: 60 Kgs.
- Tiempo de apertura aproximado: 1,2s.

TECHNICAL CHARACTERISTICS:

- Speed control by variable voltage, variable frequency incorporated.
- Operated by a signal (one or two) of any voltage 12v-24v AC or DC.
- Supply 220v-240v single-phase AC.
- Opening speed adjustable up to 1000 mm/s.
- Closing speed adjustable up to 600 mm/s.
- Closing force against an obstacle adjustable from 4 to 12 Kgs.
- Weight in stainless steel finish: 60 Kgs.
- Approximate opening time: 1,2s.

PL 700, con puerta de rellano semiautomática y pisadera de 80mm.
CO 700, with hinged semi-automatic landing door and flush sill of 80mm.

*OPCIONAL: MIRILLAS PUERTA / OPTION: VISION PANEL

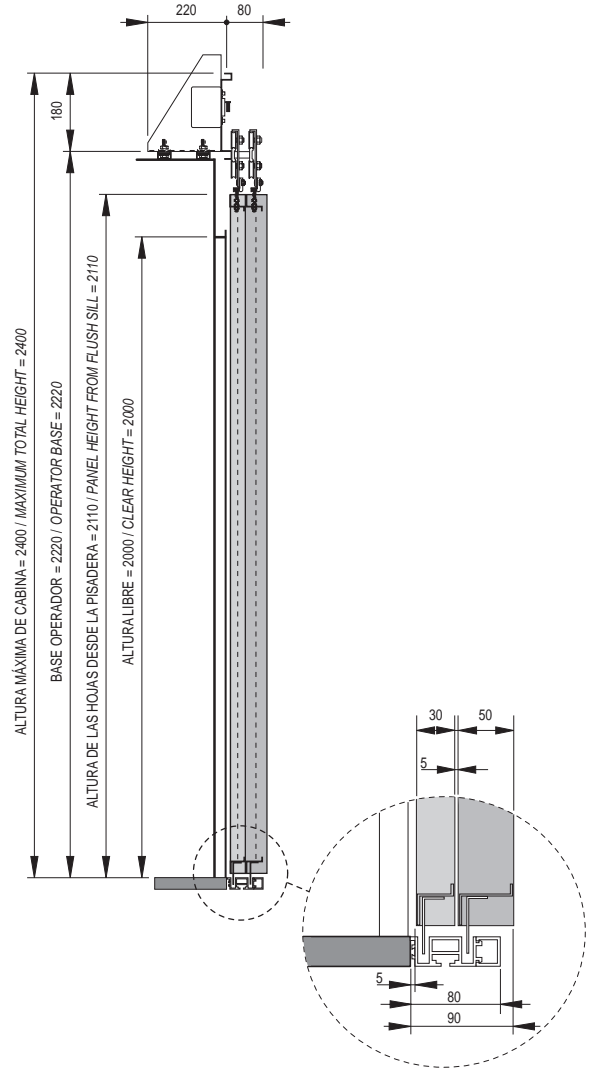
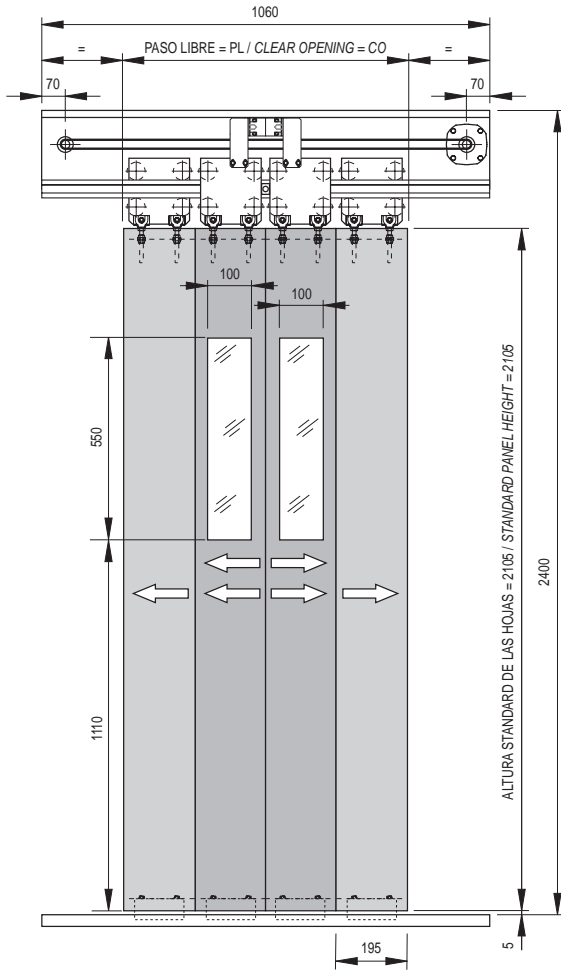

PUERTA CERRADA / CLOSED DOOR

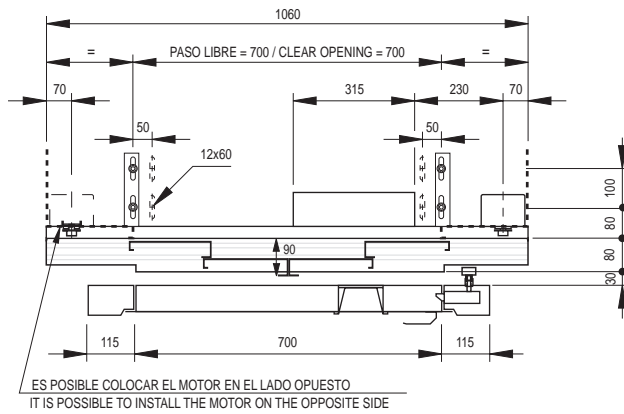

ES POSIBLE COLOCAR EL MOTOR EN EL LADO OPUESTO
IT IS POSSIBLE TO INSTALL THE MOTOR ON THE OPPOSITE SIDE

PUERTA ABIERTA / OPEN DOOR

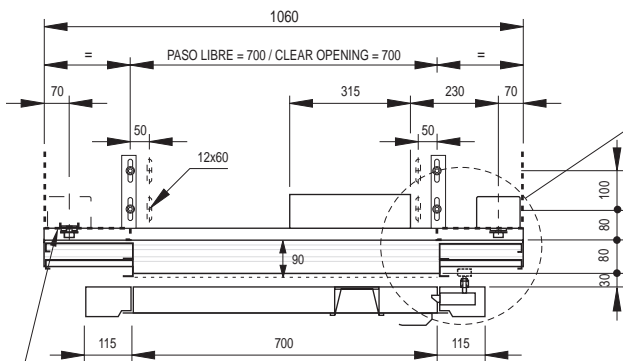

ES POSIBLE COLOCAR EL MOTOR EN EL LADO OPUESTO
IT IS POSSIBLE TO INSTALL THE MOTOR ON THE OPPOSITE SIDE

Pisadera / Sill = 80 mm.
Medidas de hojas / Panels measurements = 30 mm y 50 mm.
Total ancho hojas / Total width panels = 90 mm.

Puerta de rellano sin cerco, especial para reformas
Landing door without frames, for modernization

*: EN POSICIÓN DE PUERTA ABIERTA, EL ENCLAVAMIENTO SOBRESALE 40 mm EN PL 600 Y 15 mm EN PL 700.
*: IN OPEN DOOR POSITION, THE LOCKING DEVICE STICKS OUT 40 mm IN CO 600 AND 15 mm IN CO 700.

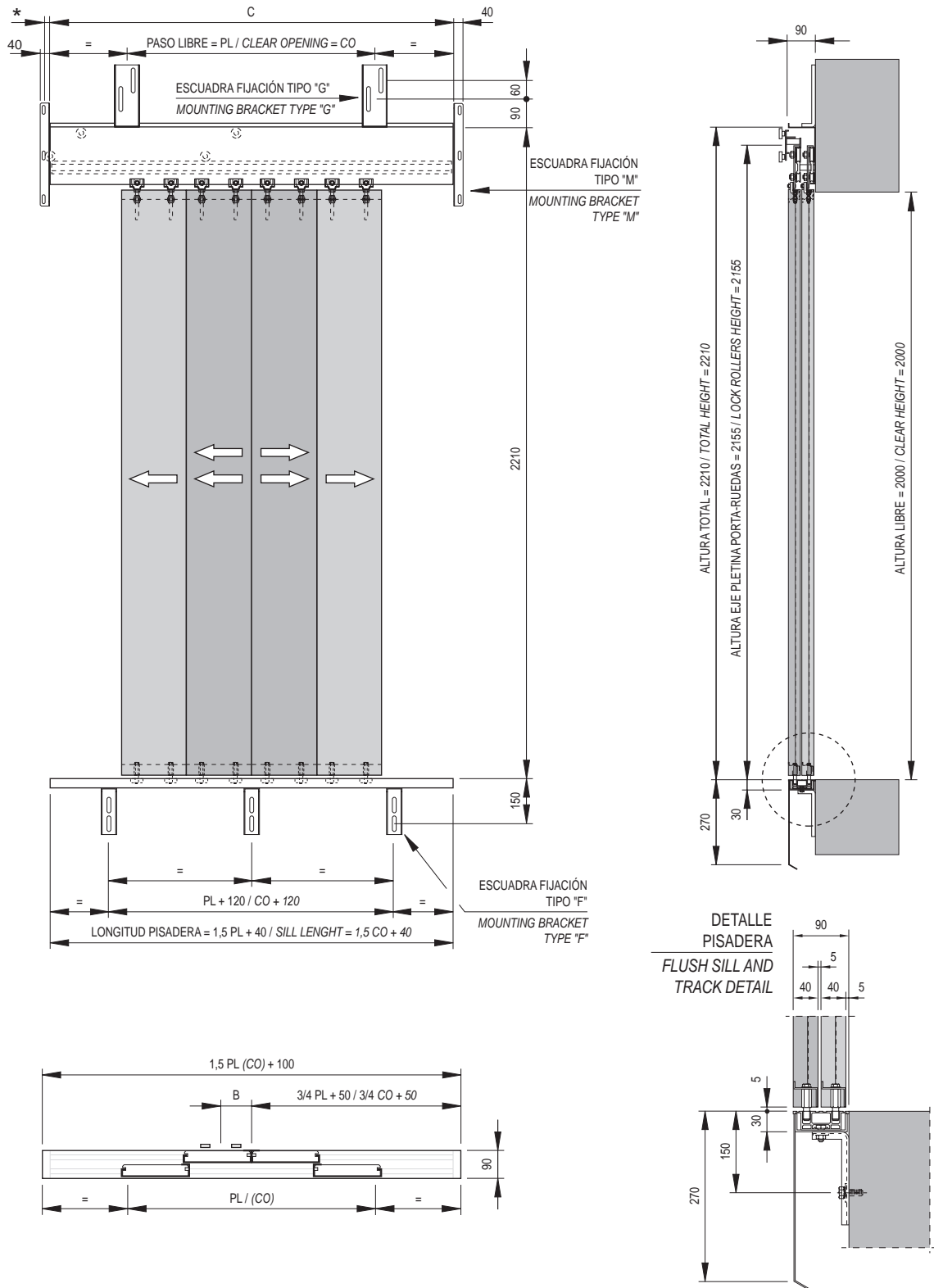

| PL / CO | 600 | 650 | 700 | 750 | 800 | 900 | 1000 | 1100 | 1200 | 1300 | 1400 | 1500 | 1600 |
|---------|------|------|------|------|------|------|------|------|------|------|------|------|------|
| B | 100 | 100 | 100 | 100 | 100 | 100 | 160 | 160 | 160 | 160 | 160 | 160 | 160 |
| C | 1000 | 1075 | 1150 | 1225 | 1300 | 1450 | 1600 | 1750 | 1900 | 2050 | 2200 | 2350 | 2500 |

| Tipo de escuadra Bracket type | Cantidad Quantity | |
|----------------------------------|----------------------|--------|
| M | 2 | 2 |
| G | 2 | 3 |
| F | 3 | 5 |
| PL / CO | ≤ 1000 | ≥ 1100 |

12.6.

PUERTA DE RELLANO CENTRAL DE 4 HOJAS 4 PANELS CENTRE PARTING LANDING DOOR

50/11

Fermator
AUTOMATIC DOORS FOR LIFTS

Puerta de rellano sin cerco, especial para reformas
Landing door without frames, for modernization

*: EN POSICIÓN DE PUERTA ABIERTA, EL ENCLAVAMIENTO SOBRESALE 40 mm EN PL 600 Y 15 mm EN PL 700.
*: IN OPEN DOOR POSITION, THE LOCKING DEVICE STICKS OUT 40 mm IN CO 600 AND 15 mm IN CO 700.

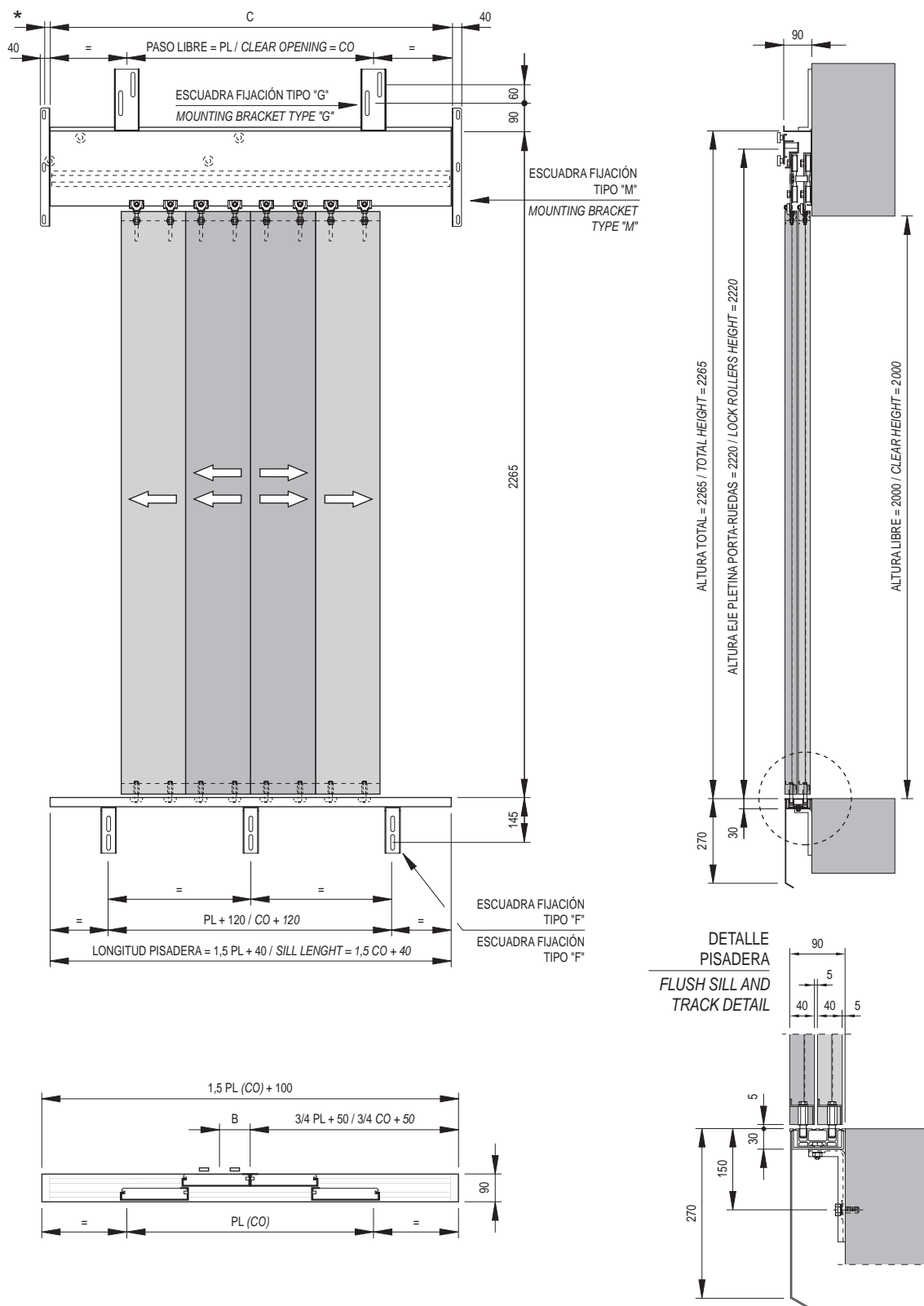

12

| PL / CO | 600 | 650 | 700 | 750 | 800 | 900 | 1000 | 1100 | 1200 | 1300 | 1400 | 1500 | 1600 |
|---------|------|------|------|------|------|------|------|------|------|------|------|------|------|
| B | 100 | 100 | 100 | 100 | 100 | 100 | 160 | 160 | 160 | 160 | 160 | 160 | 160 |
| C | 1000 | 1075 | 1150 | 1225 | 1300 | 1450 | 1600 | 1750 | 1900 | 2050 | 2200 | 2350 | 2500 |

| Tipo de escuadra Bracket type | Cantidad Quantity | |
|----------------------------------|----------------------|-------------|
| L | 2 | 2 |
| G | 3 | 5 |
| F | 3 | 5 |
| PL / CO | ≤ 1000 | ≥ 1100 |

Puerta de rellano sin cerco, especial para reformas
Landing door without frames, for modernization

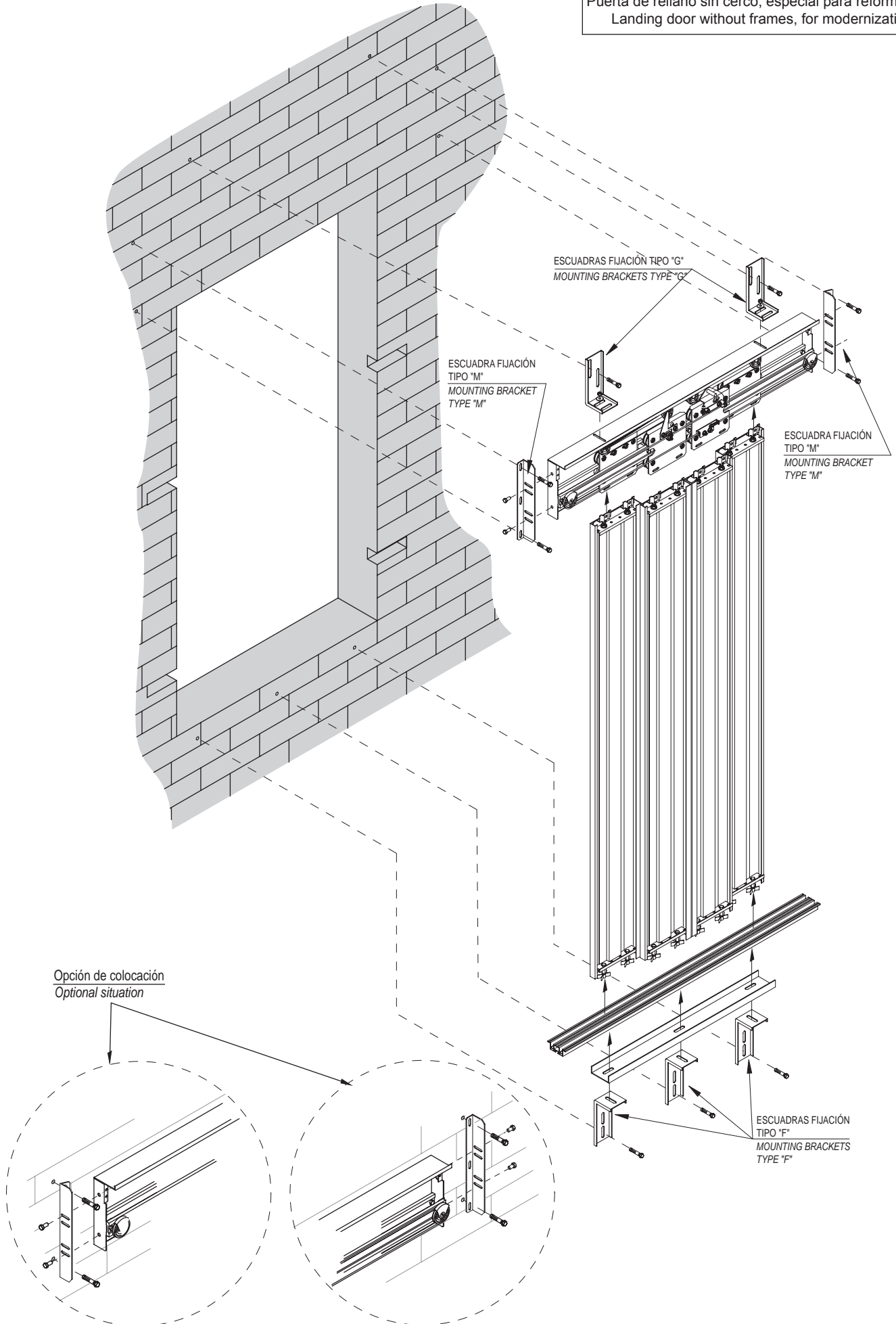

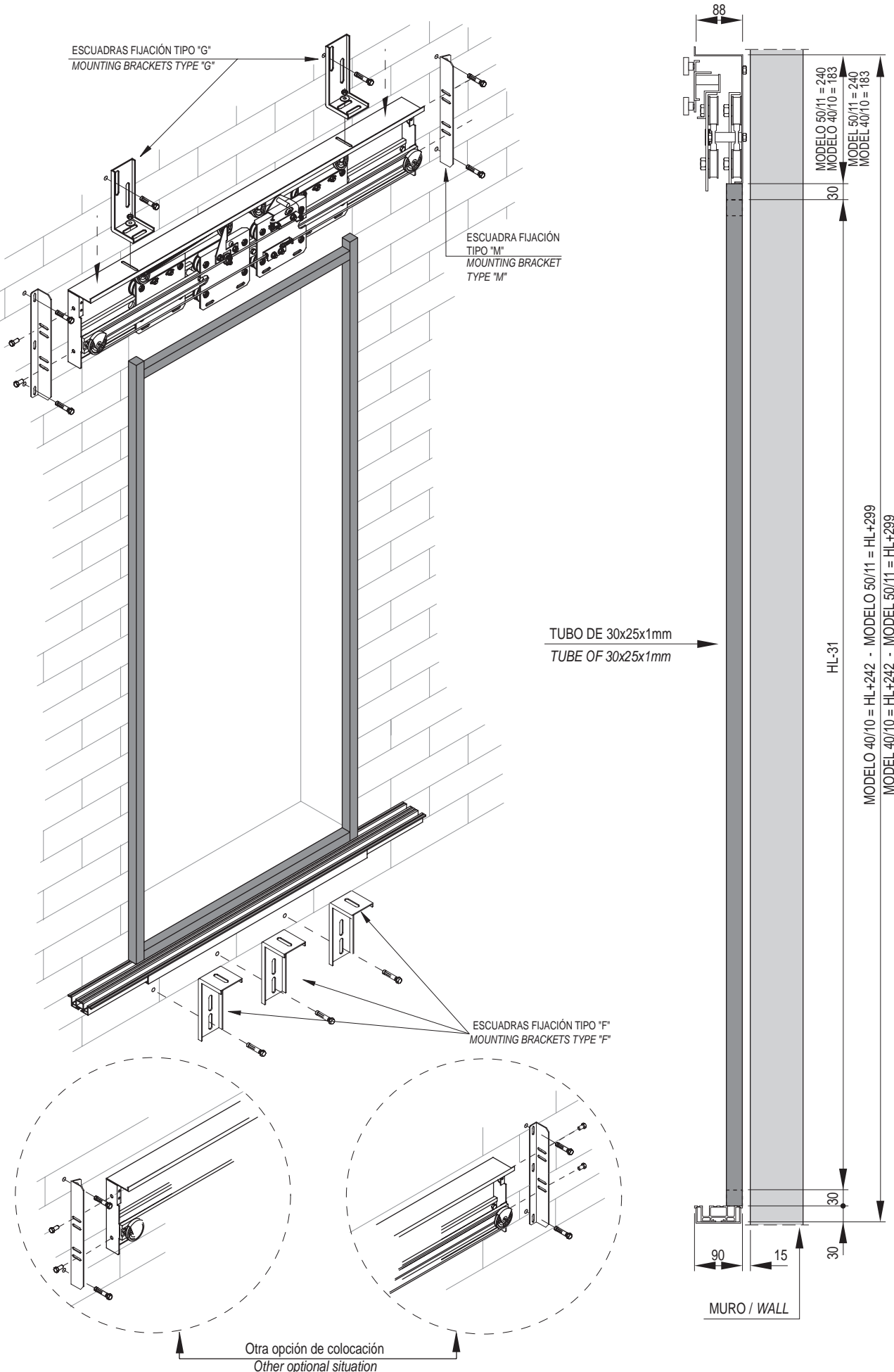

Con puerta de rellano automática y pisadera de 70mm
With automatic landing door and flush sill of 70mm

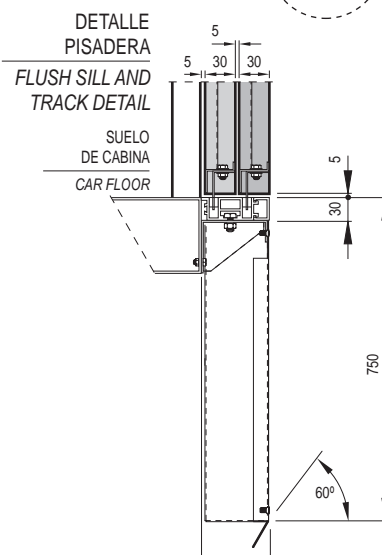
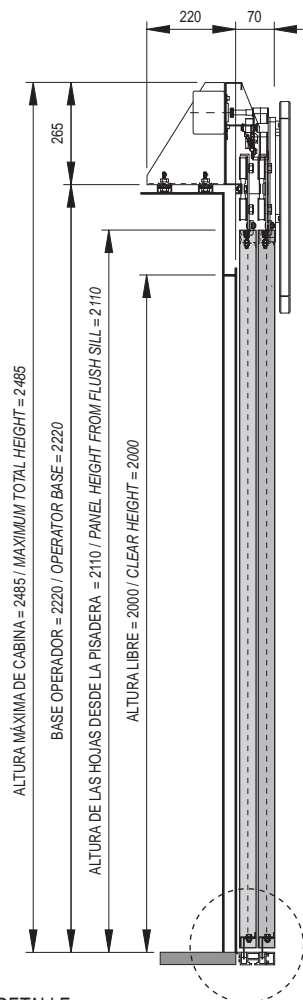
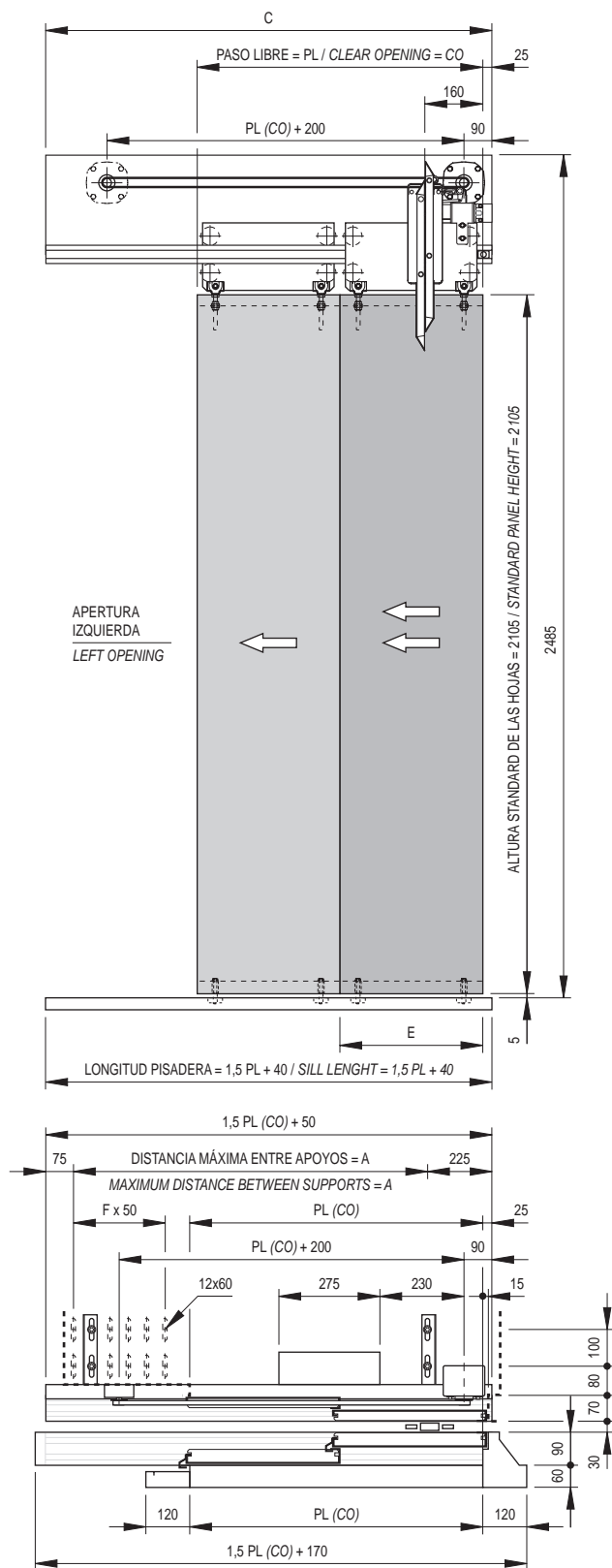

| PL / CO | 600 | 650 | 700 | 750 | 800 | 850 | 900 | 1000 | 1100 | 1200 | 1300 | 1400 | 1500 | 1600 |
|-------------------|------|------|------|------|------|------|------|------|------|------|------|-------|-------|------|
| A | 650 | 725 | 800 | 875 | 950 | 1025 | 1100 | 1250 | 1400 | 1550 | 1700 | 1850 | 2000 | 2150 |
| C | 950 | 1025 | 1100 | 1175 | 1250 | 1325 | 1400 | 1550 | 1700 | 1850 | 2000 | 2150 | 2300 | 2450 |
| E | 320 | 325 | 370 | 395 | 420 | 445 | 470 | 520 | 570 | 620 | 670 | 720 | 770 | 820 |
| F | 4 | 4 | 5 | 5 | 6 | 6 | 6 | 7 | 8 | 8 | 8 | 8 | 9 | 9 |
| TIEMPO / TIME (s) | 1,56 | 1,62 | 1,68 | 1,74 | 1,8 | 1,85 | 1,91 | 2,01 | 2,11 | 2,2 | 2,3 | 2,4 | 2,5 | 2,6 |
| PESO / TIME (kg) | 52,5 | 57 | 61,5 | 66 | 70 | 74,5 | 79 | 87,5 | 96,5 | 105 | 114 | 122,5 | 131,5 | 140 |

Con puerta de rellano semiautomática y pisadera de 70mm.
With hinged semi-automatic landing door and flush sill of 70mm.

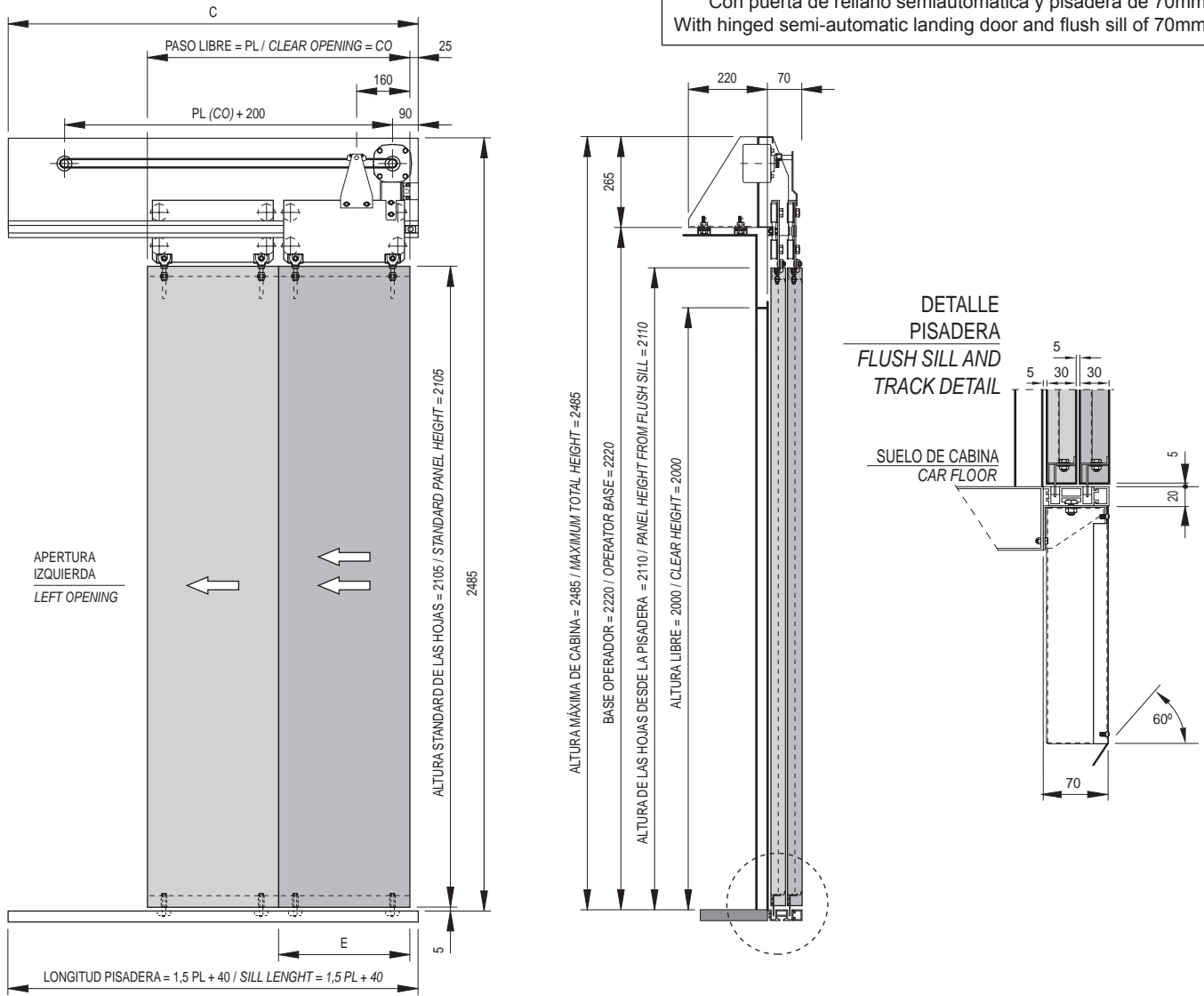

12 PUERTA CABINA T2H CON SEMIAUTOMÁTICA MISMO SENTIDO DE APERTURA T2 CABIN DOOR WITH HINGED LANDING DOOR TO THE SAME OPENING SIDE

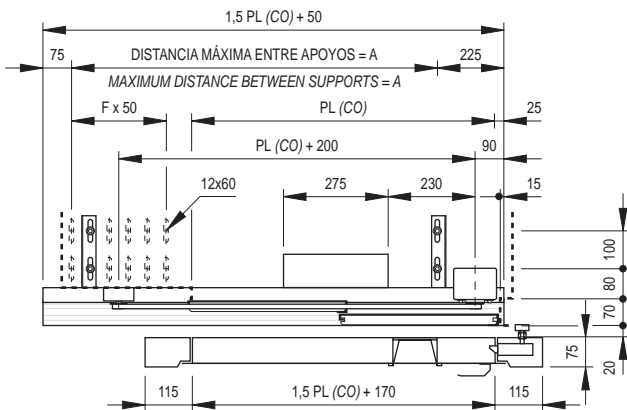

PUERTA CABINA T2H CON SEMIAUTOMÁTICA SENTIDO DE APERTURA OPUESTA T2 CABIN DOOR WITH HINGED LANDING DOOR TO THE OPPOSITE OPENING SIDE

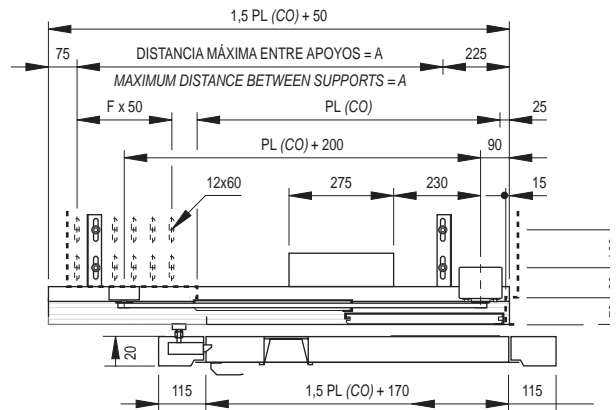

| PL / CO | 600 | 650 | 700 | 750 | 800 | 850 | 900 | 1000 | 1100 | 1200 | 1300 | 1400 | 1500 | 1600 |
|-------------------|------|------|------|------|------|------|------|------|------|------|------|-------|-------|------|
| A | 650 | 725 | 800 | 875 | 950 | 1025 | 1100 | 1250 | 1400 | 1550 | 1700 | 1850 | 2000 | 2150 |
| C | 950 | 1025 | 1100 | 1175 | 1250 | 1325 | 1400 | 1550 | 1700 | 1850 | 2000 | 2150 | 2300 | 2450 |
| E | 320 | 325 | 370 | 395 | 420 | 445 | 470 | 520 | 570 | 620 | 670 | 720 | 770 | 820 |
| F | 4 | 4 | 5 | 5 | 6 | 6 | 6 | 7 | 8 | 8 | 8 | 8 | 9 | 9 |
| TIEMPO / TIME (s) | 1,56 | 1,62 | 1,68 | 1,74 | 1,8 | 1,85 | 1,91 | 2,01 | 2,11 | 2,2 | 2,3 | 2,4 | 2,5 | 2,6 |
| PESO / TIME (kg) | 52,5 | 57 | 61,5 | 66 | 70 | 74,5 | 79 | 87,5 | 96,5 | 105 | 114 | 122,5 | 131,5 | 140 |

Puerta de rellano sin cerco, especial para reformas
Landing door without frames, for modernization

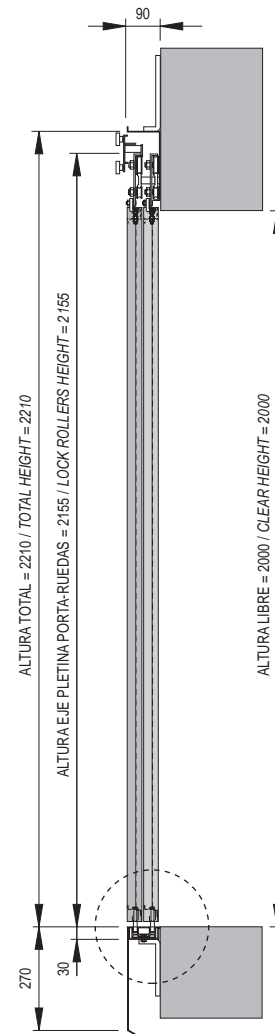
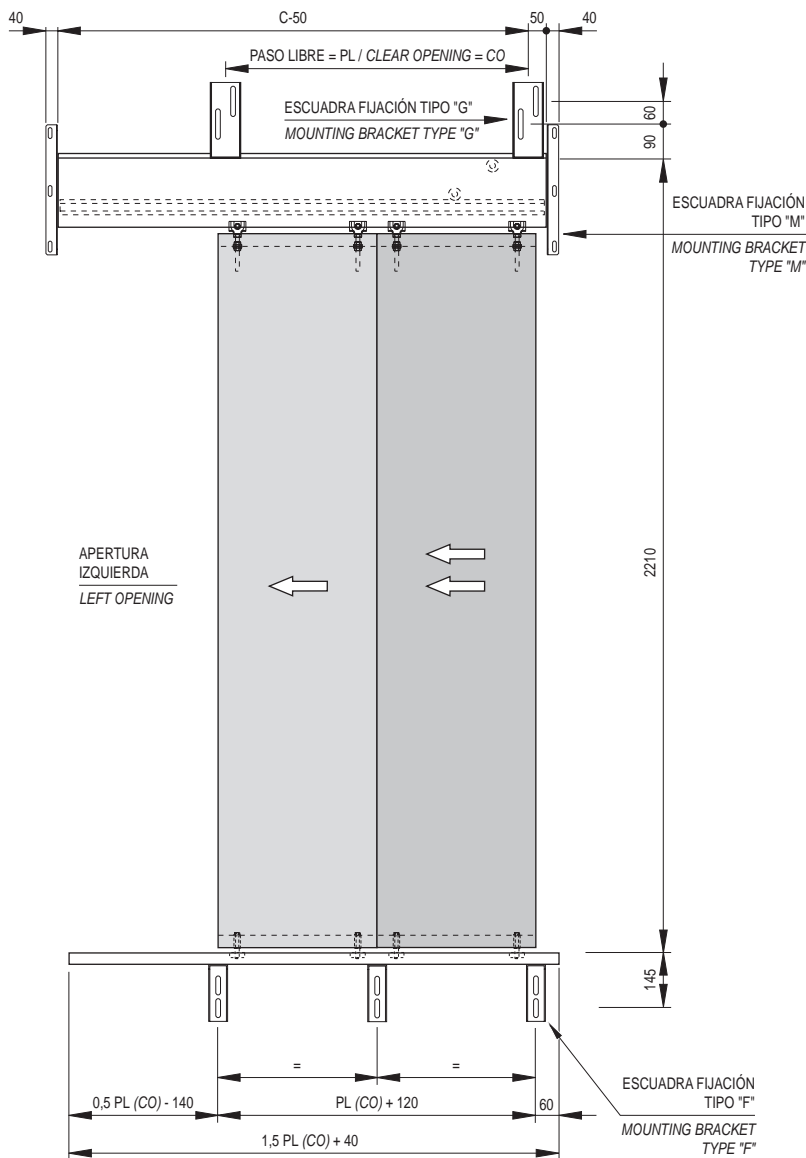

DETALLE PISADERA
FLUSH SILL AND TRACK DETAIL

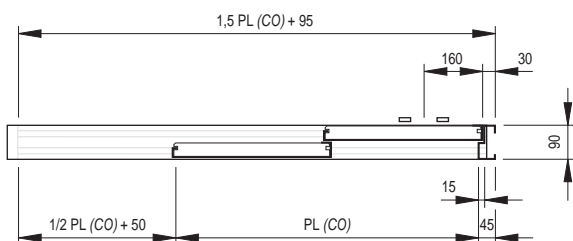
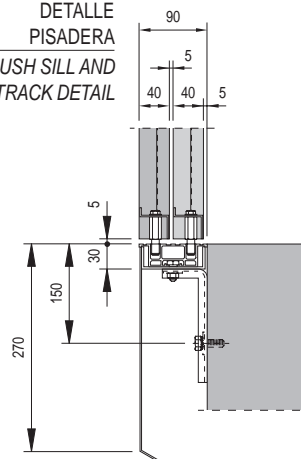

| | | | | | | | | | | | | | |
|---------|------|------|------|------|------|------|------|------|------|------|------|------|------|
| PL / CO | 600 | 650 | 700 | 750 | 800 | 900 | 1000 | 1100 | 1200 | 1300 | 1400 | 1500 | 1600 |
| C | 1000 | 1075 | 1150 | 1225 | 1300 | 1450 | 1600 | 1750 | 1900 | 2050 | 2200 | 2350 | 2500 |

| Tipo de escuadra Bracket type | Cantidad Quantity | |
|----------------------------------|----------------------|---------|
| L | 2 | 2 |
| G | 3 | 5 |
| F | 3 | 5 |
| PL / CO | <= 1000 | >= 1100 |

Puerta de rellano sin cerco, especial para reformas
Landing door without frames, for modernization

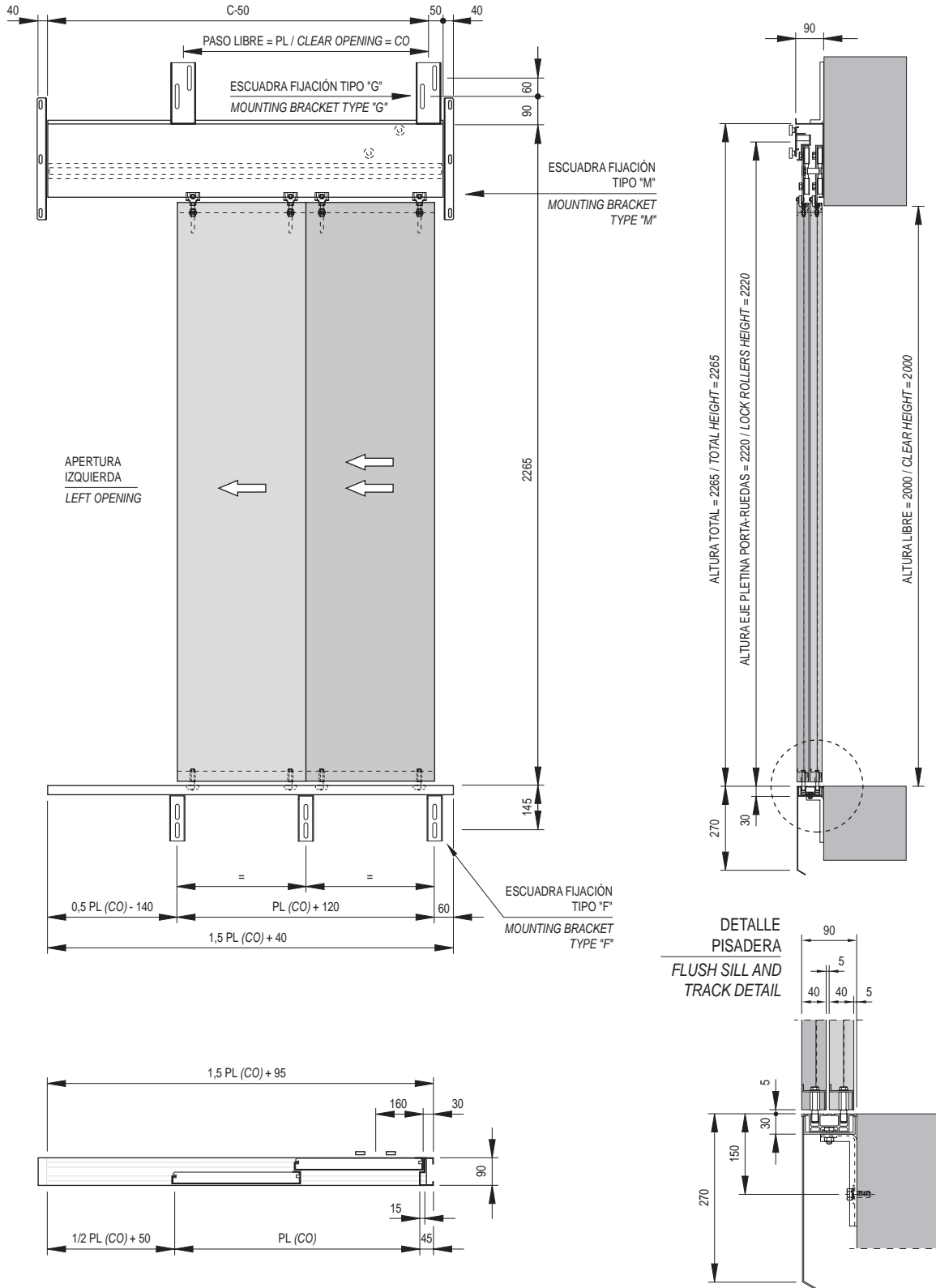

| | | | | | | | | | | | | | |
|---------|------|------|------|------|------|------|------|------|------|------|------|------|------|
| PL / CO | 600 | 650 | 700 | 750 | 800 | 900 | 1000 | 1100 | 1200 | 1300 | 1400 | 1500 | 1600 |
| C | 1000 | 1075 | 1150 | 1225 | 1300 | 1450 | 1600 | 1750 | 1900 | 2050 | 2200 | 2350 | 2500 |

| Tipo de escuadra Bracket type | Cantidad Quantity | |
|----------------------------------|----------------------|---------|
| L | 2 | 2 |
| G | 3 | 5 |
| F | 3 | 5 |
| PL / CO | <= 1000 | >= 1100 |

Puerta de rellano sin cerco, especial para reformas
Landing door without frames, for modernization

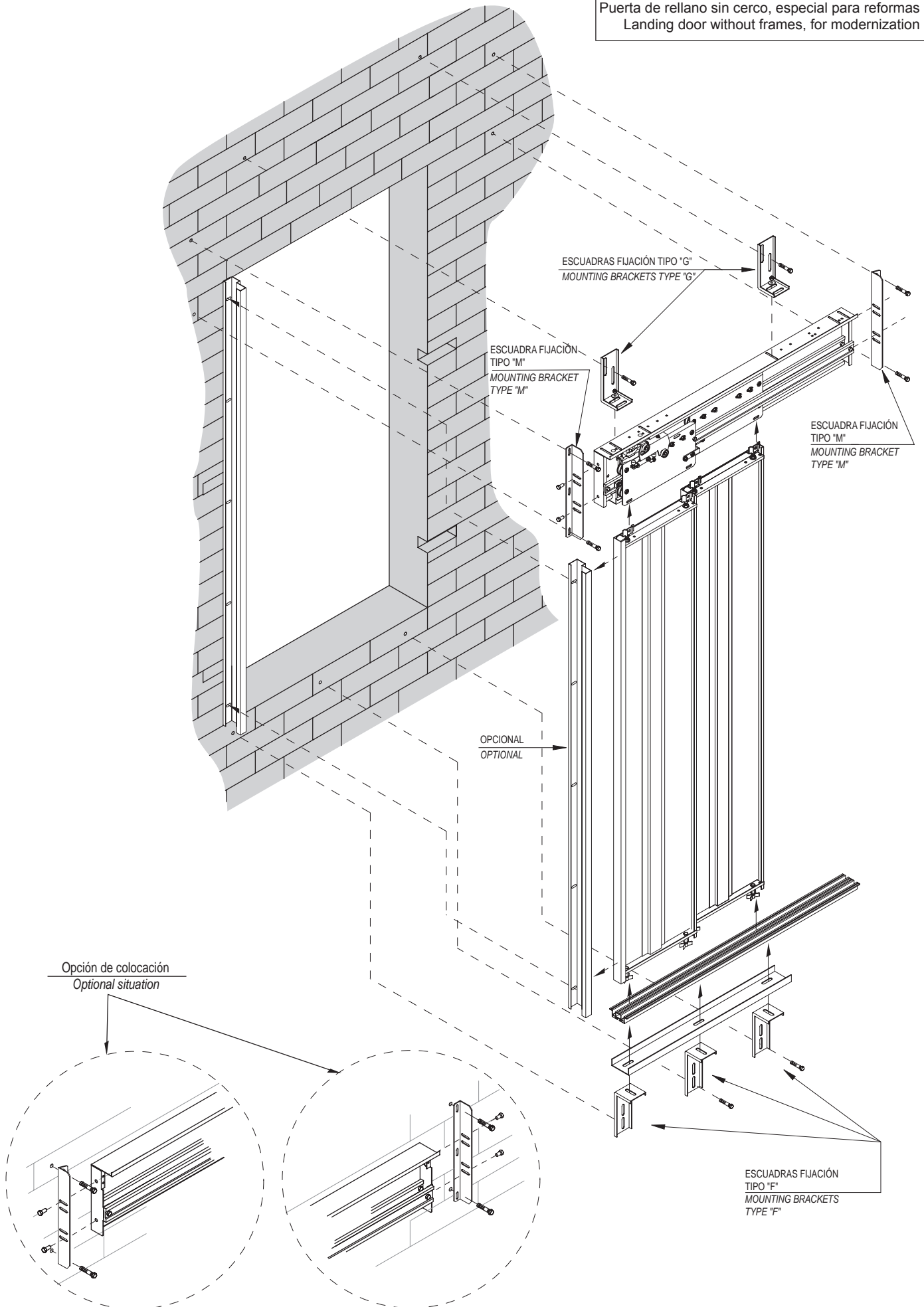

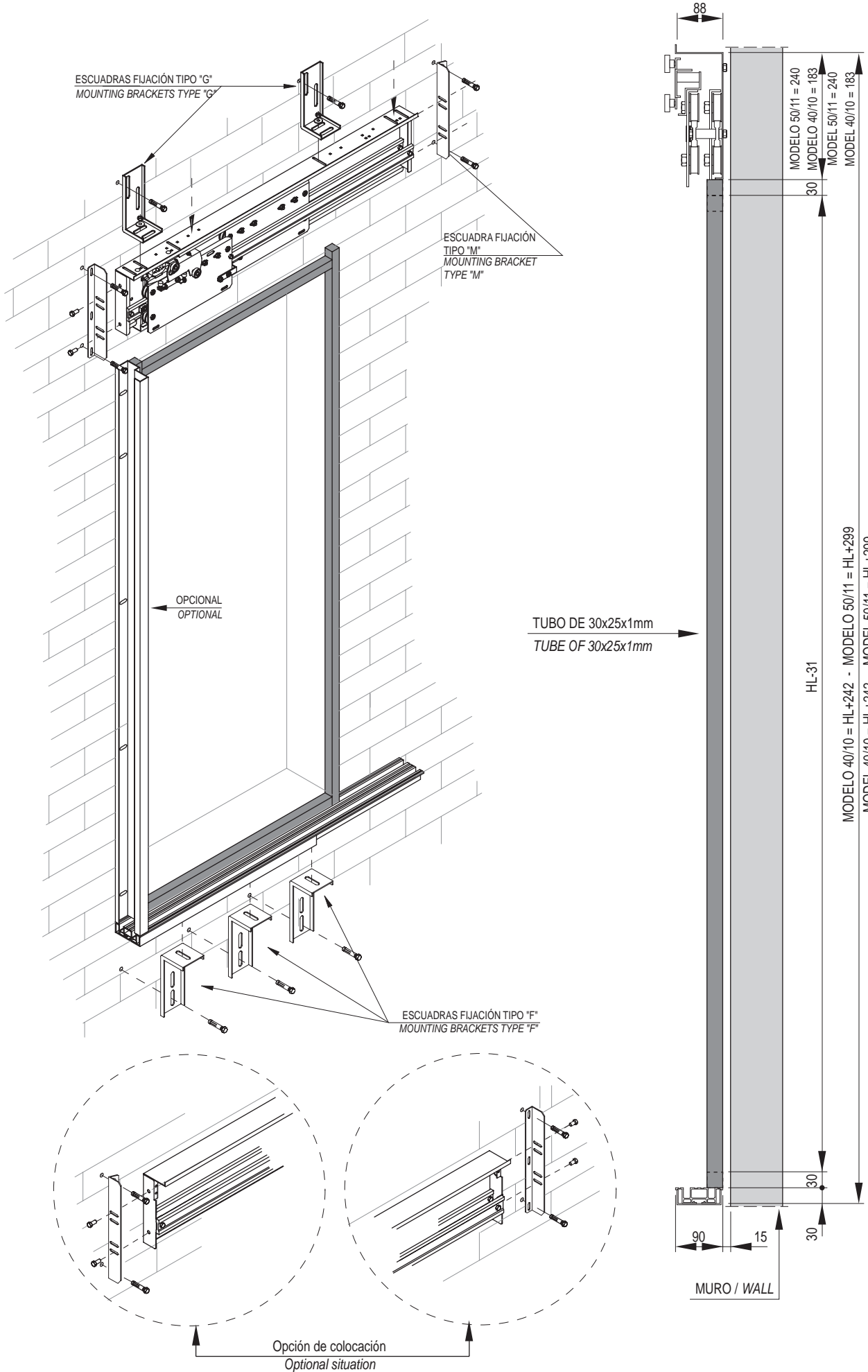

Con puerta de relleno automática y pisadera de 90mm.
With automatic landing door and flush sill of 90mm.

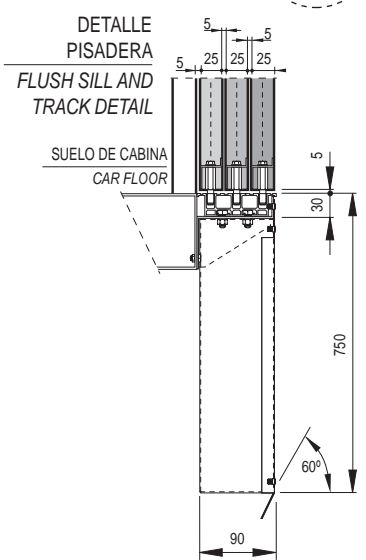
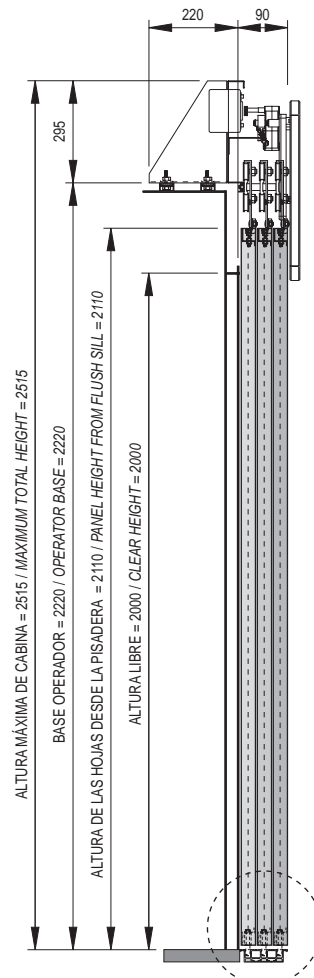
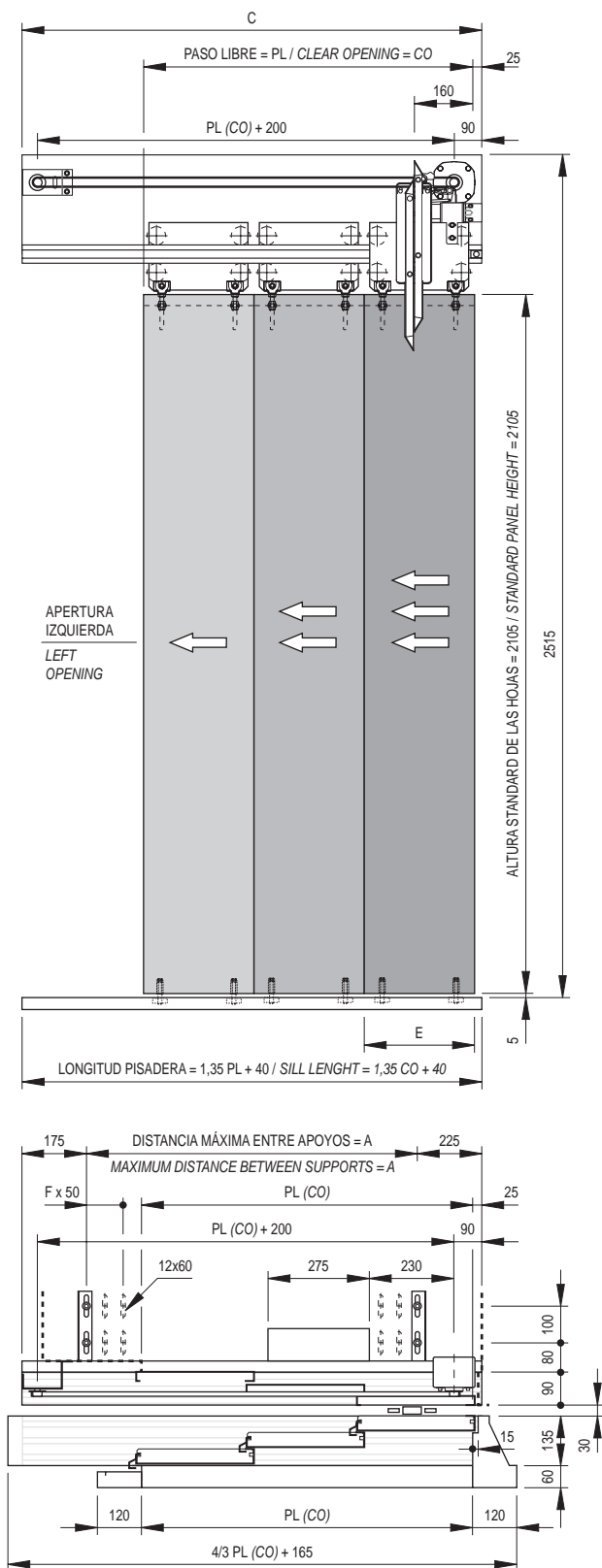

| PL / CO | 600 | 650 | 700 | 750 | 800 | 850 | 900 | 1000 | 1100 | 1200 | 1300 | 1400 |
|-------------------|------|------|------|------|------|------|------|------|------|-------|------|-------|
| A | 495 | 545 | 595 | 645 | 720 | 795 | 845 | 995 | 1145 | 1295 | 1395 | 1545 |
| C | 895 | 945 | 995 | 1045 | 1120 | 1195 | 1245 | 1395 | 1545 | 1695 | 1795 | 1945 |
| E | 220 | 235 | 253 | 270 | 285 | 305 | 320 | 353 | 385 | 420 | 453 | 485 |
| F | 4 | 4 | 4 | 4 | 4 | 4 | 4 | 4 | 4 | 5 | 5 | 6 |
| TIEMPO / TIME (s) | 1,56 | 1,62 | 1,68 | 1,74 | 1,8 | 1,85 | 1,91 | 2,01 | 2,11 | 2,2 | 2,3 | 2,4 |
| PESO / TIME (kg) | 57 | 61,5 | 66 | 71 | 75,5 | 80,5 | 85 | 94,5 | 104 | 113,5 | 123 | 132,5 |

Con puerta de rellano semiautomática y pisadera de 90mm.
With hinged semi-automatic landing door and flush sill of 90mm.

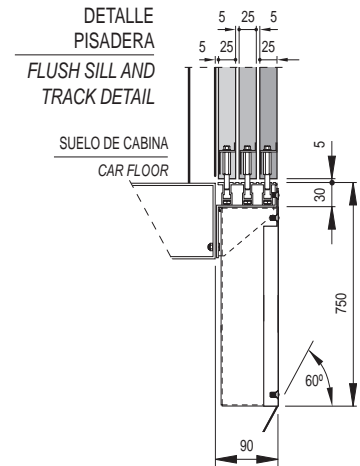
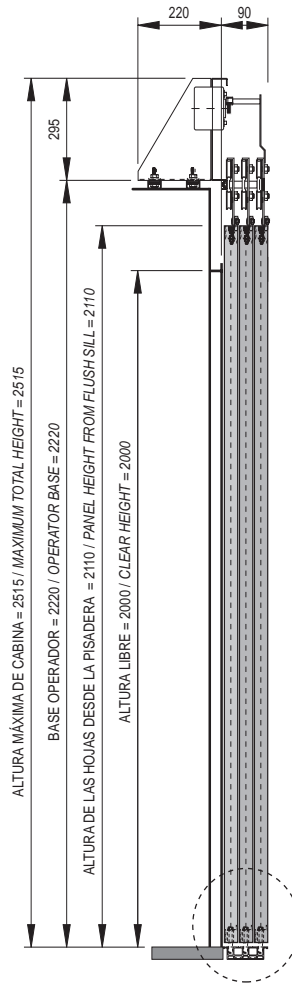
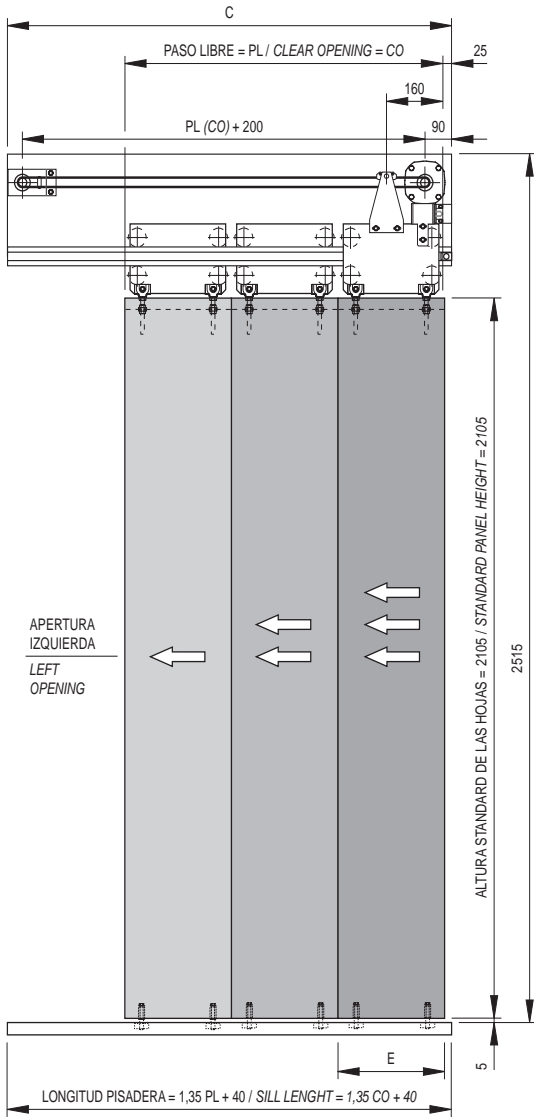

SEMIAUTOMÁTICA MISMA MANO
HINGED DOOR SENSE OPENING

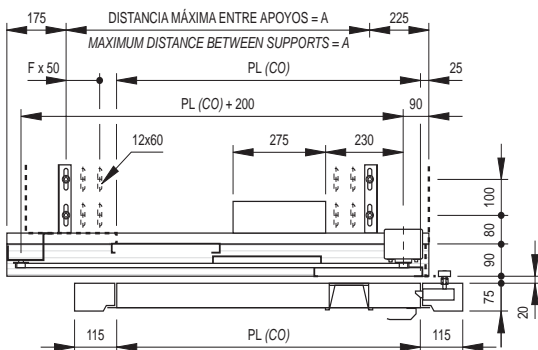

SEMIAUTOMÁTICA CON LADO CONTRARIO
HINGED DOOR WITH OPPOSITE SENSE OF OPENING

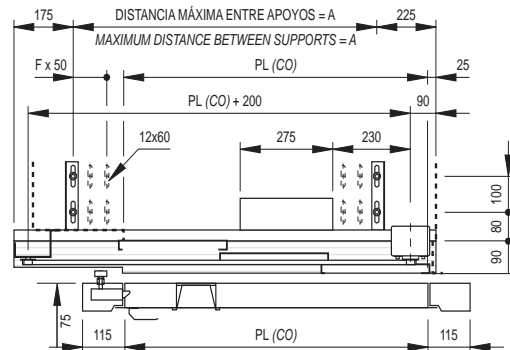

| PL / CO | 600 | 650 | 700 | 750 | 800 | 850 | 900 | 1000 | 1100 | 1200 | 1300 | 1400 |
|-------------------|------|------|------|------|------|------|------|------|------|-------|------|-------|
| A | 495 | 545 | 595 | 645 | 720 | 795 | 845 | 995 | 1145 | 1295 | 1395 | 1545 |
| C | 895 | 945 | 995 | 1045 | 1120 | 1195 | 1245 | 1395 | 1545 | 1695 | 1795 | 1945 |
| E | 220 | 235 | 253 | 270 | 285 | 305 | 320 | 353 | 385 | 420 | 453 | 485 |
| F | 4 | 4 | 4 | 4 | 4 | 4 | 4 | 4 | 4 | 5 | 5 | 6 |
| TIEMPO / TIME (s) | 1,56 | 1,62 | 1,68 | 1,74 | 1,8 | 1,85 | 1,91 | 2,01 | 2,11 | 2,2 | 2,3 | 2,4 |
| PESO / TIME (kg) | 57 | 61,5 | 66 | 71 | 75,5 | 80,5 | 85 | 94,5 | 104 | 113,5 | 123 | 132,5 |

Con puerta de rellano semiautomática y pisadera de 70mm
With hinged semi-automatic landing door and flush sill of 70mm

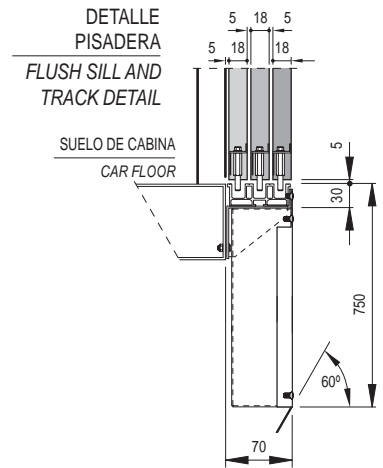
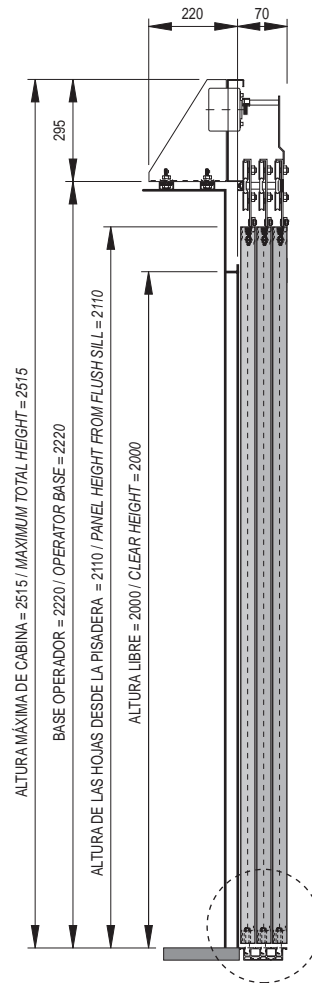
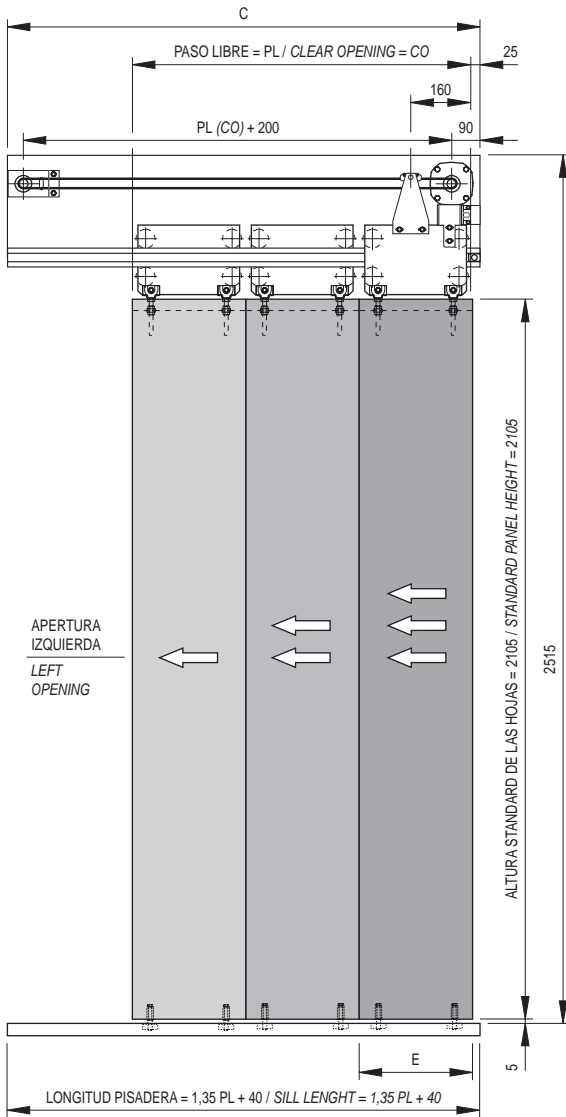

SEMIAUTOMÁTICA MISMA MANO
HINGED DOOR SENSE OPENING

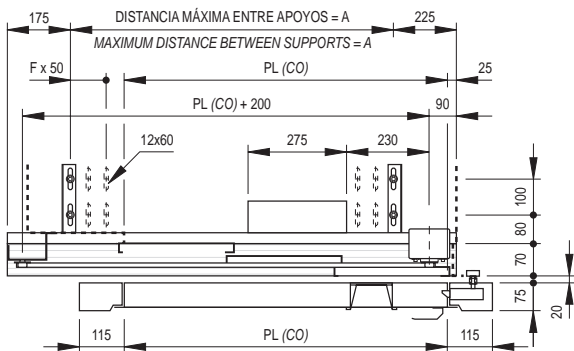

SEMIAUTOMÁTICA CON LADO CONTRARIO
HINGED DOOR WITH OPPOSITE SENSE OF OPENING

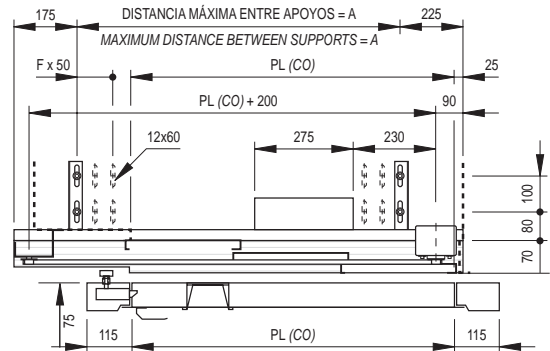

| PL / CO | 600 | 650 | 700 | 750 | 800 | 850 | 900 | 1000 | 1100 | 1200 | 1300 | 1400 |
|-------------------|------|------|------|------|------|------|------|------|------|-------|------|-------|
| A | 495 | 545 | 595 | 645 | 720 | 795 | 845 | 995 | 1145 | 1295 | 1395 | 1545 |
| C | 895 | 945 | 995 | 1045 | 1120 | 1195 | 1245 | 1395 | 1545 | 1695 | 1795 | 1945 |
| E | 220 | 235 | 253 | 270 | 285 | 305 | 320 | 353 | 385 | 420 | 453 | 485 |
| F | 4 | 4 | 4 | 4 | 4 | 4 | 4 | 4 | 4 | 5 | 5 | 6 |
| TIEMPO / TIME (s) | 1,56 | 1,62 | 1,68 | 1,74 | 1,8 | 1,85 | 1,91 | 2,01 | 2,11 | 2,2 | 2,3 | 2,4 |
| PESO / TIME (kg) | 57 | 61,5 | 66 | 71 | 75,5 | 80,5 | 85 | 94,5 | 104 | 113,5 | 123 | 132,5 |

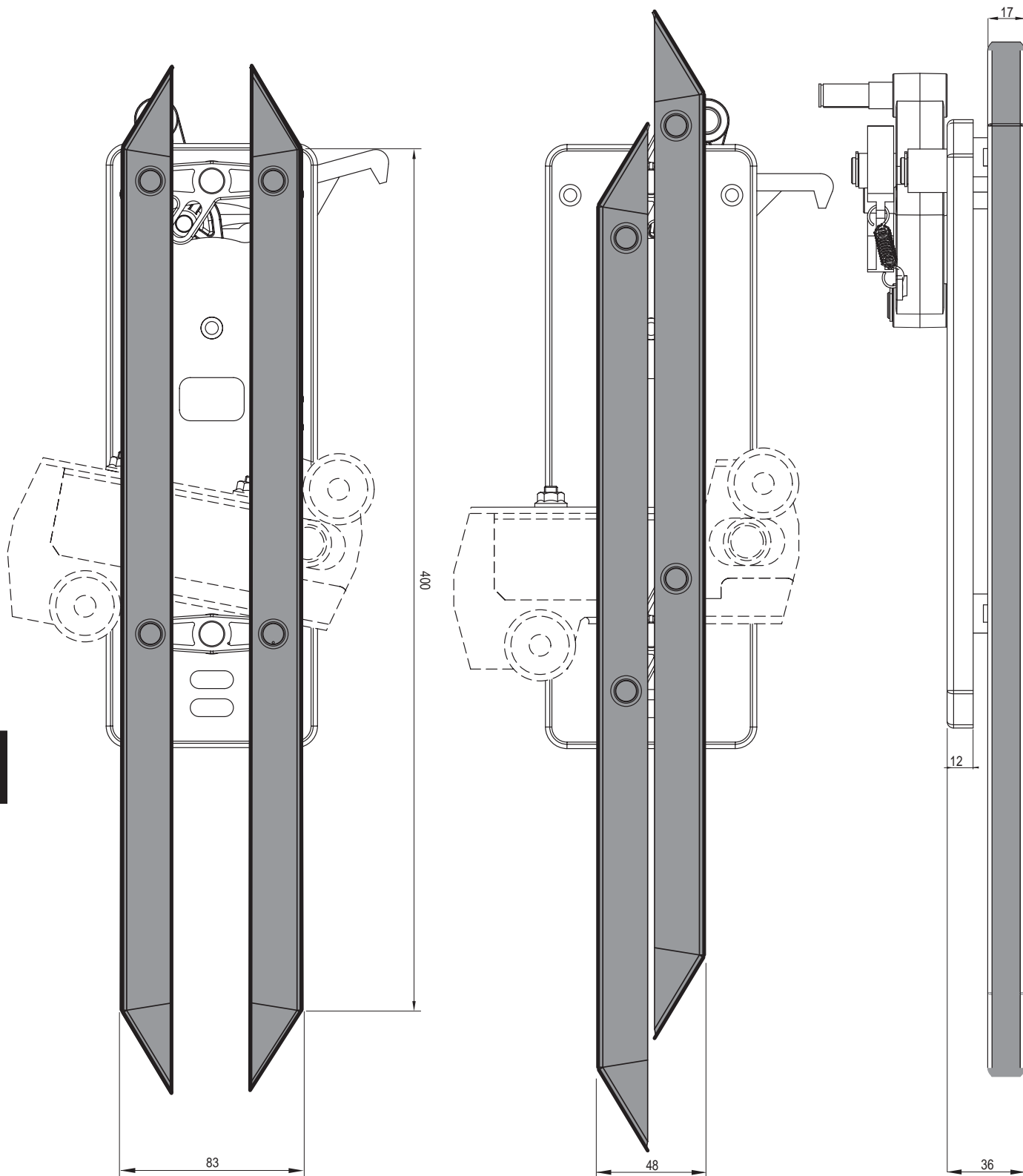

Para todo tipo de puertas de cabina telescópicas
For all type of side opening car door

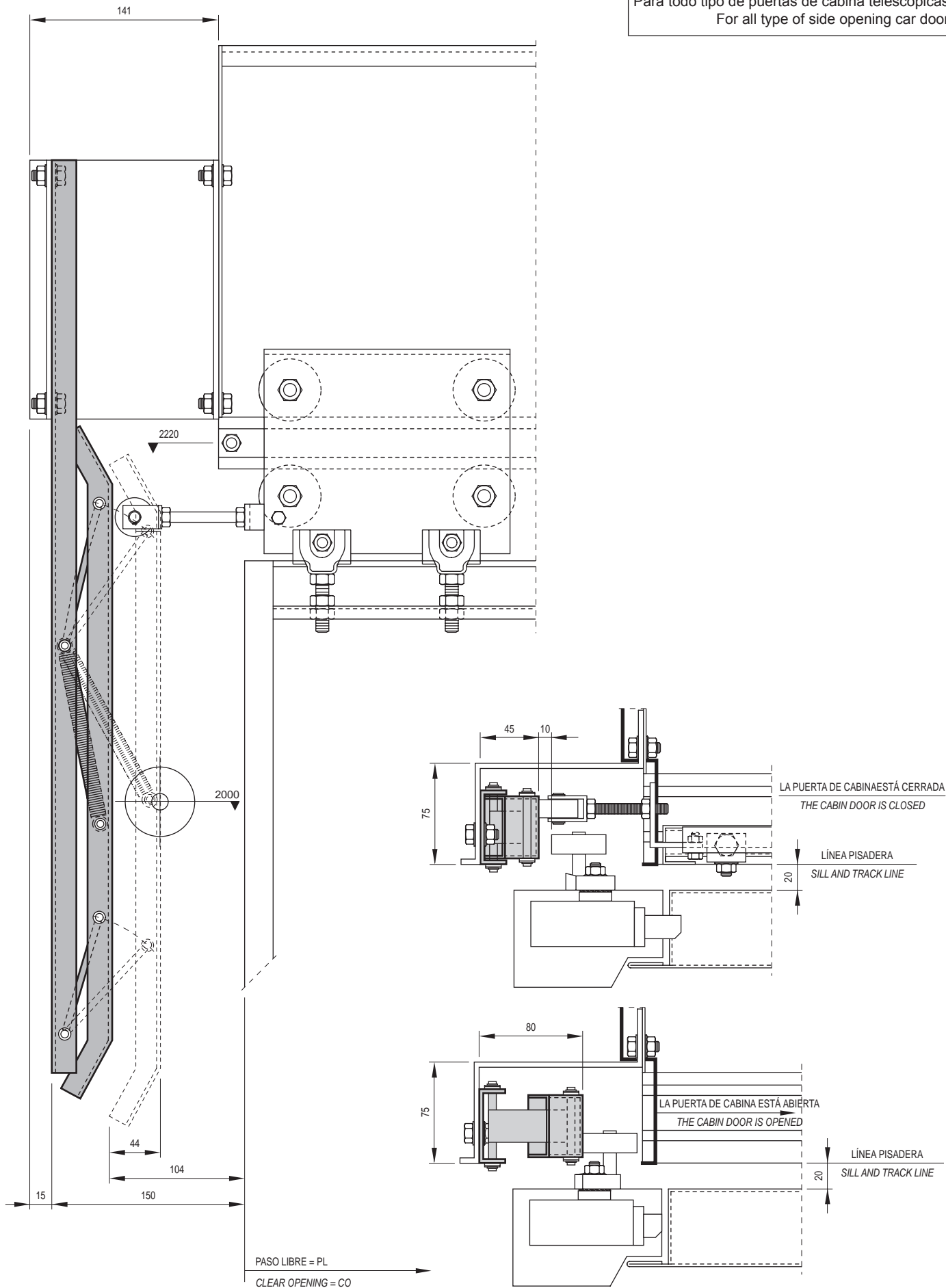

Para todo tipo de puertas de cabina telescópicas
For all type of side opening car door

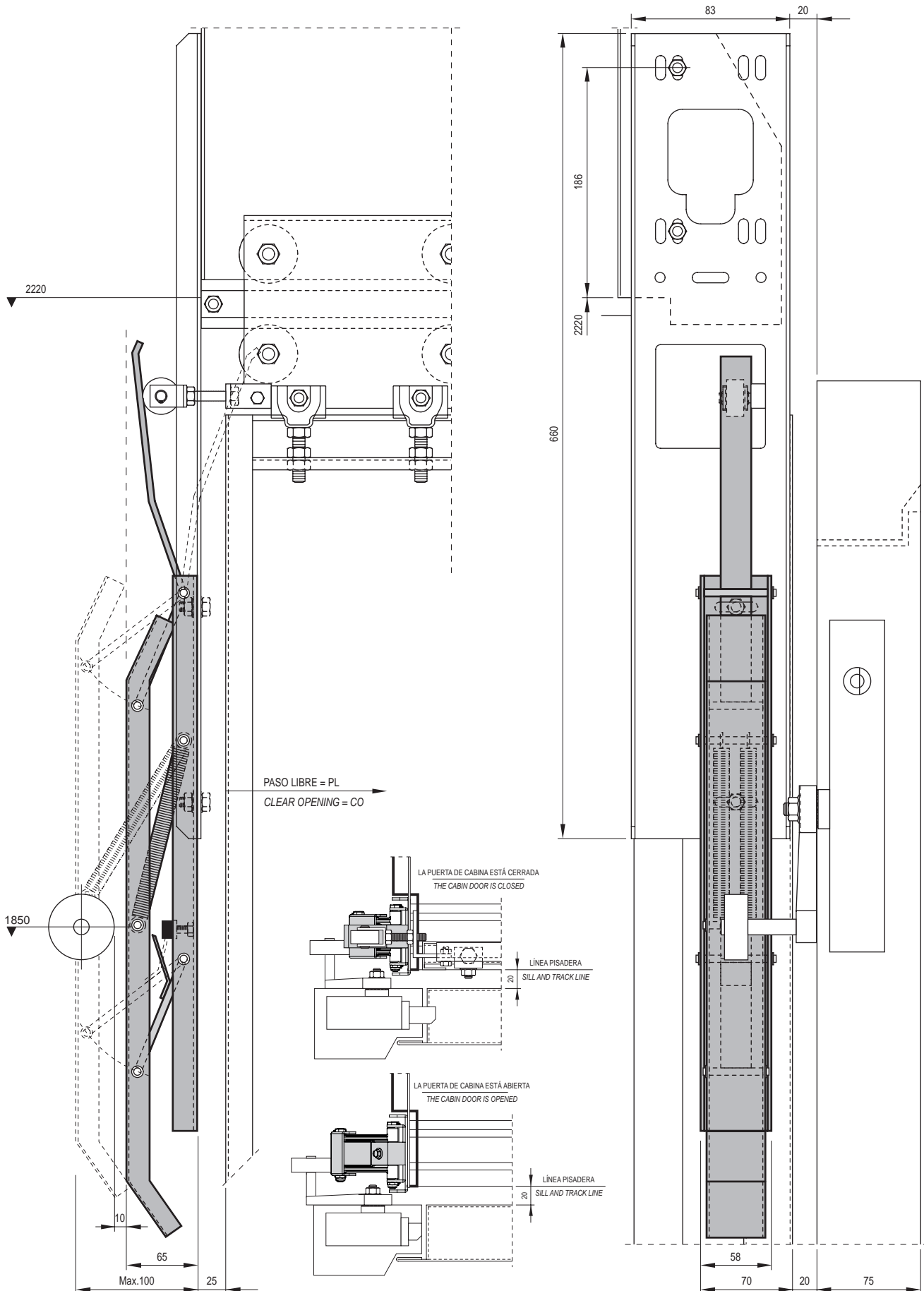

Para todo tipo de puertas de cabina telescópicas
For all type of side opening car door

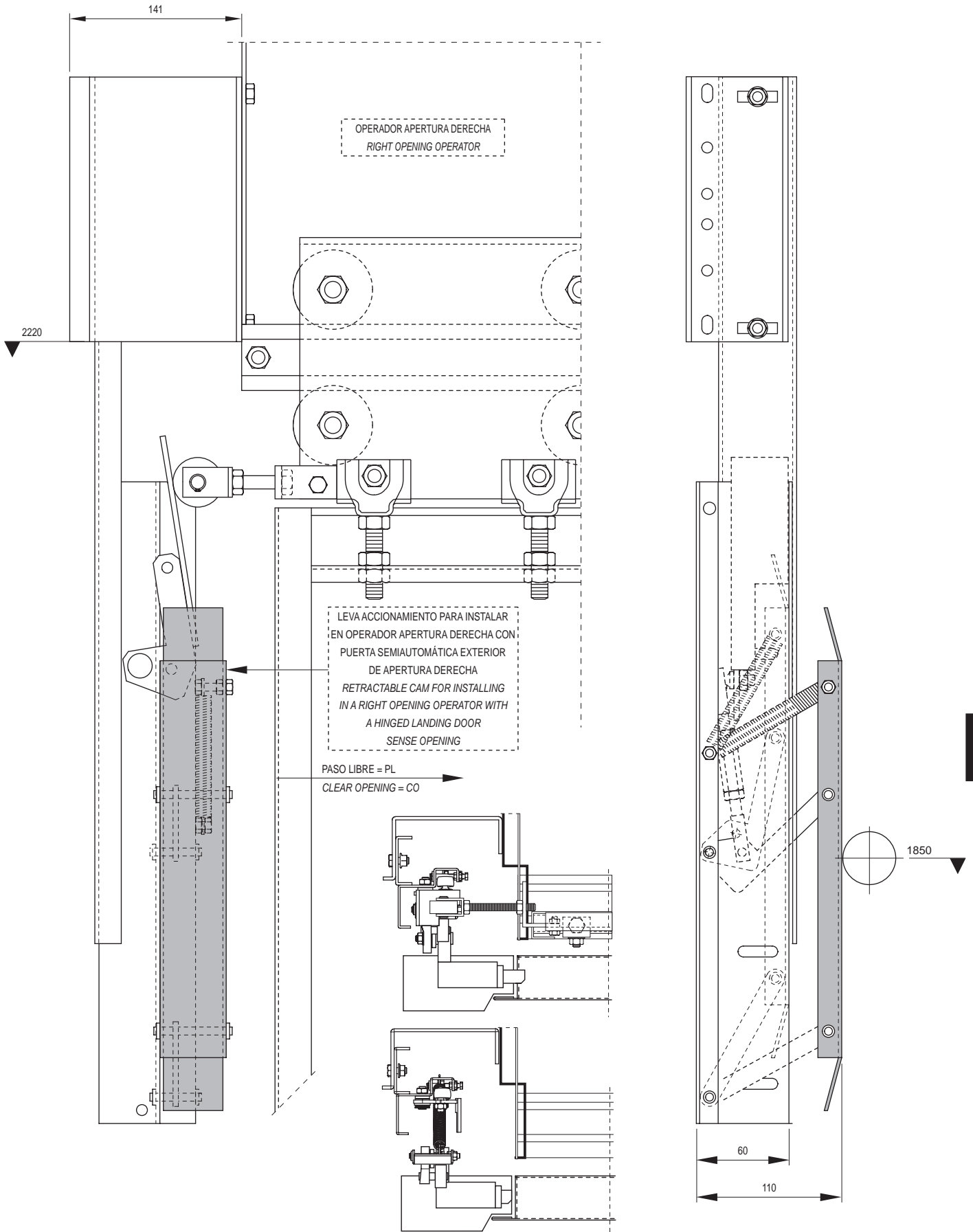

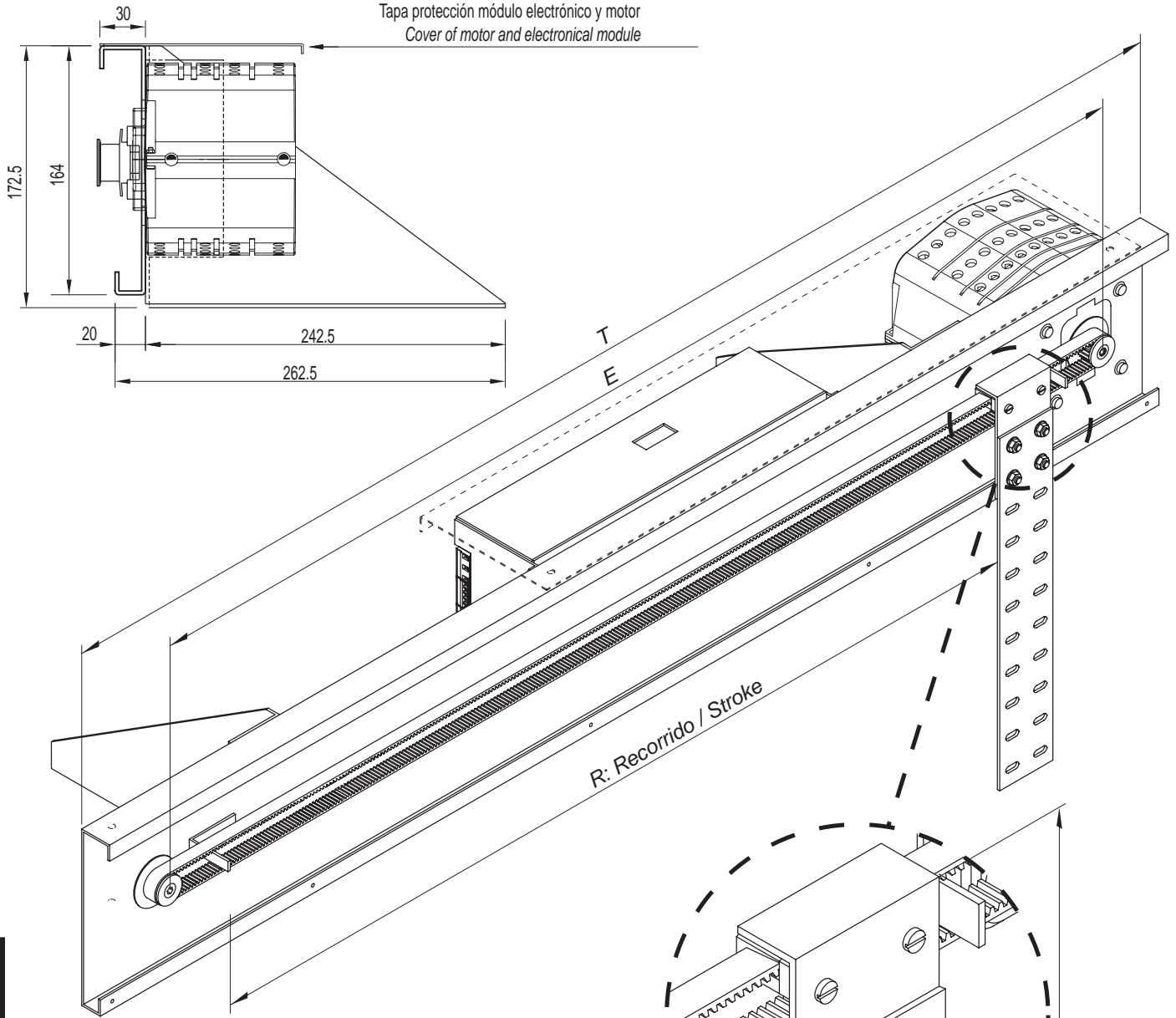

12

| Referencia Reference | R | T | E | M | | |
|-------------------------|------|------|------|---|--|--|
| KVF-VF00.00000.0320.1 | 320 | 700 | 597 | 1 | | |
| KVF-VF00.00000.0420.1 | 420 | 800 | 697 | 1 | | |
| KVF-VF00.00000.0520.1 | 520 | 900 | 797 | 1 | | |
| KVF-VF00.x0000.0620.1* | 620 | 1000 | 897 | 1 | | |
| KVF-VF00.00000.0620.2 | | | | 2 | | |
| KVF-VF00.x0000.0720.1* | 720 | 1100 | 997 | 1 | | |
| KVF-VF00.00000.0720.2 | | | | 2 | | |
| KVF-VF00.x0000.0820.1* | 820 | 1200 | 1097 | 1 | | |
| KVF-VF00.00000.0820.2 | | | | 2 | | |
| KVF-VF00.x0000.0920.1* | 920 | 1300 | 1197 | 1 | | |
| KVF-VF00.00000.0920.2 | | | | 2 | | |
| KVF-VF00.x0000.1220.2* | 1220 | 1600 | 1497 | 2 | | |
| KVF-VF00.00000.1220.2 | | | | | | |
| KVF-VF00.x0000.1520.2* | 1520 | 1900 | 1797 | 2 | | |
| KVF-VF00.00000.1520.2 | | | | | | |

T: Longitud total / Total length

M: Número de motores / Number of motors

E: Entrecentros / Distance between axis

Modelo disponible
Available model

*"x" debe ser sustituida por I (izquierda) o D (derecha) en función de la apertura.
"x" must be substituted by I (left) or D (right) depending on the side of opening.

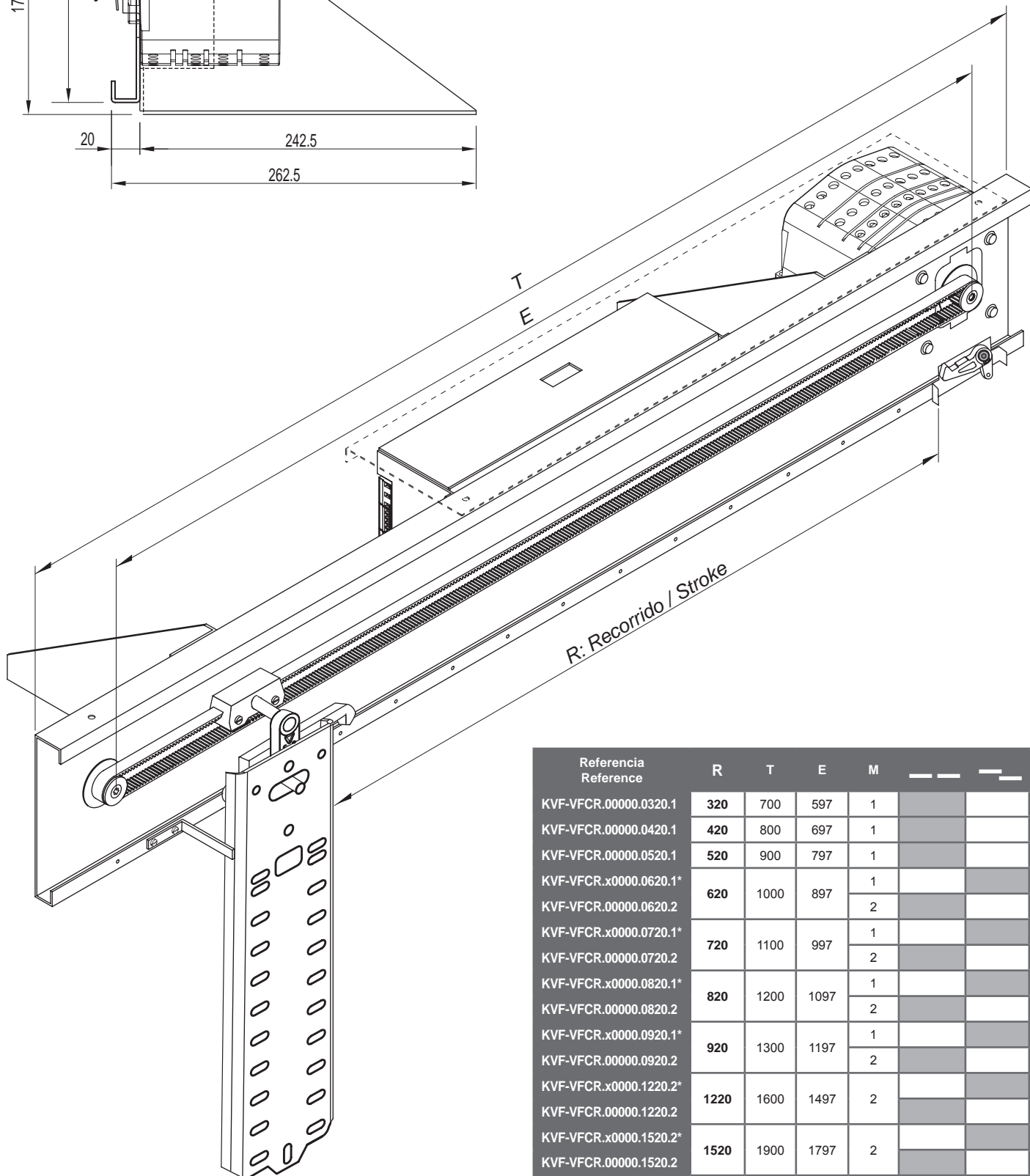
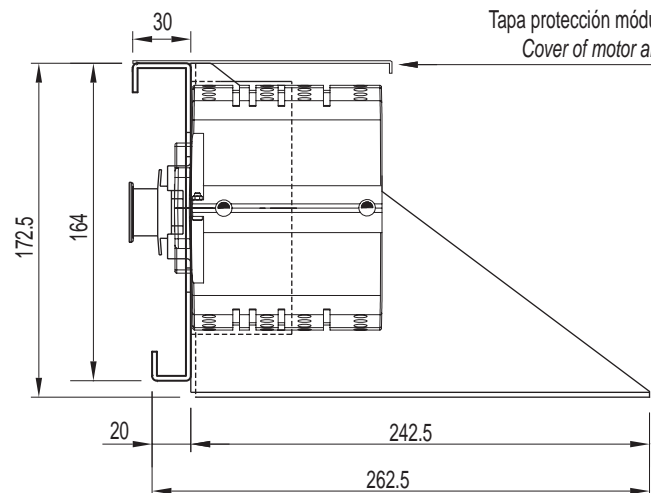

| Referencia Reference | R | T | E | M | | |
|-------------------------|------|------|------|---|--|--|
| KVF-VFCR.00000.0320.1 | 320 | 700 | 597 | 1 | | |
| KVF-VFCR.00000.0420.1 | 420 | 800 | 697 | 1 | | |
| KVF-VFCR.00000.0520.1 | 520 | 900 | 797 | 1 | | |
| KVF-VFCR.x0000.0620.1* | 620 | 1000 | 897 | 1 | | |
| KVF-VFCR.00000.0620.2 | | | | 2 | | |
| KVF-VFCR.x0000.0720.1* | 720 | 1100 | 997 | 1 | | |
| KVF-VFCR.00000.0720.2 | | | | 2 | | |
| KVF-VFCR.x0000.0820.1* | 820 | 1200 | 1097 | 1 | | |
| KVF-VFCR.00000.0820.2 | | | | 2 | | |
| KVF-VFCR.x0000.0920.1* | 920 | 1300 | 1197 | 1 | | |
| KVF-VFCR.00000.0920.2 | | | | 2 | | |
| KVF-VFCR.x0000.1220.2* | 1220 | 1600 | 1497 | 2 | | |
| KVF-VFCR.00000.1220.2 | | | | | | |
| KVF-VFCR.x0000.1520.2* | 1520 | 1900 | 1797 | 2 | | |
| KVF-VFCR.00000.1520.2 | | | | | | |

* "x" debe ser sustituida por I (izquierda) o D (derecha) en función de la apertura.
"x" must be substituted by I (left) or D (right) depending on the side of opening.

T: Longitud total / Total length

M: Número de motores / Number of motors

E: Entrecentros / Distance between axis

Modelo disponible
Available model

Ferrotec

AUTOMATIC DOORS FOR LIFTS

SOLUCIONES ESPECÍFICAS
SPECIFIC SOLUTIONS

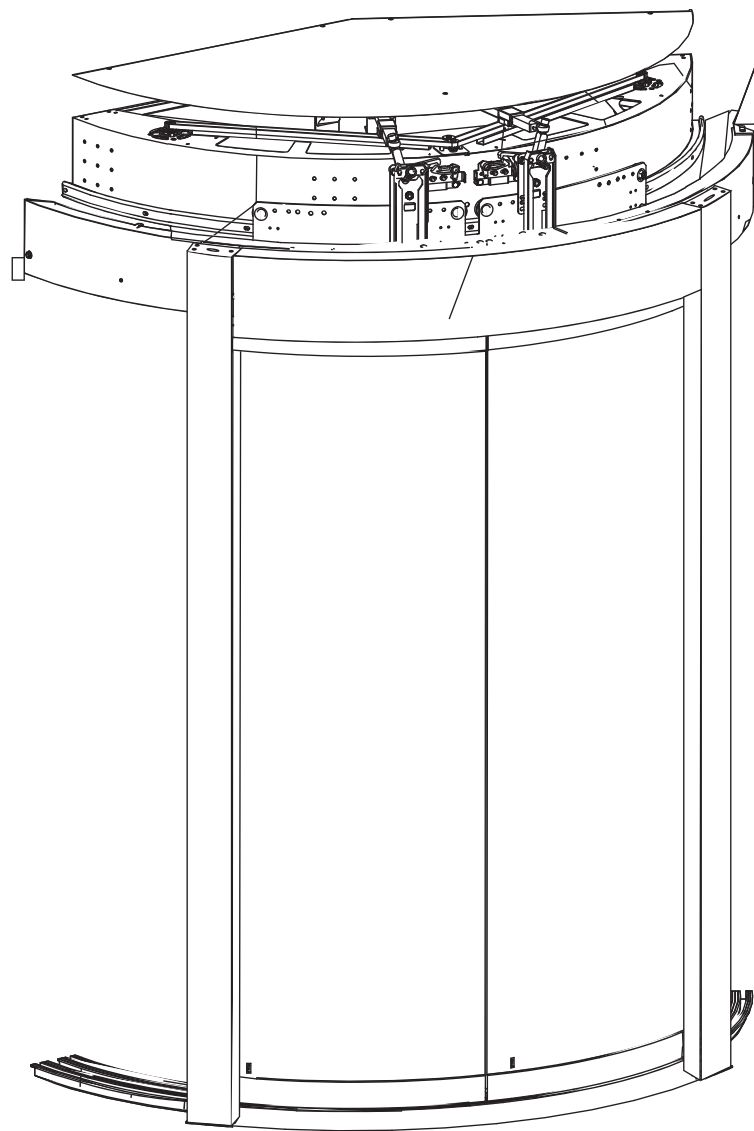

Se muestra modelo C4. Disponible también para cualquier número de hojas y para apertura central o telescópica. Para más información consultar con nuestro departamento técnico.

C4 model is shown. Also available for any number of panels and for side opening or centre parting doors. Ask with our technical department for more information.

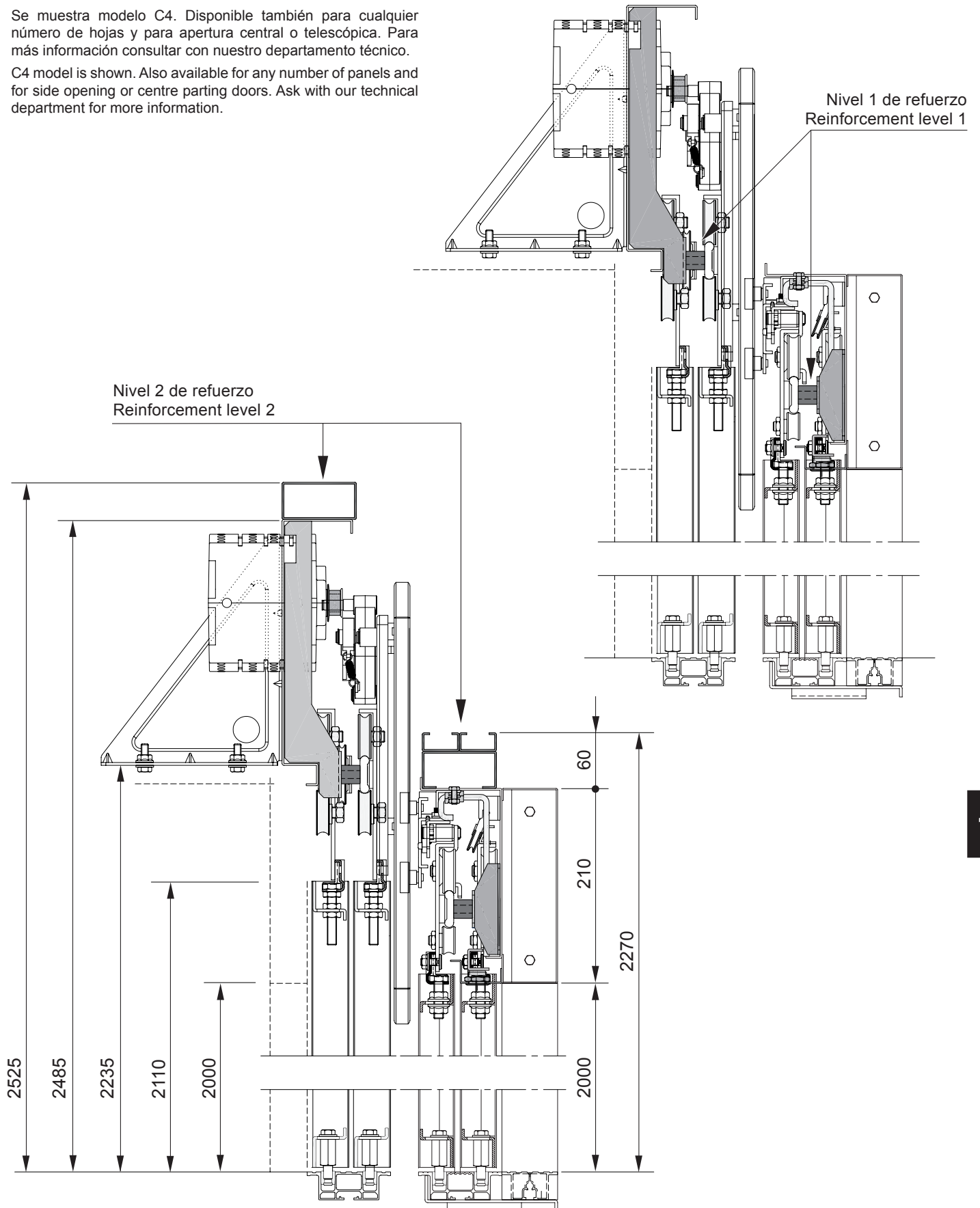

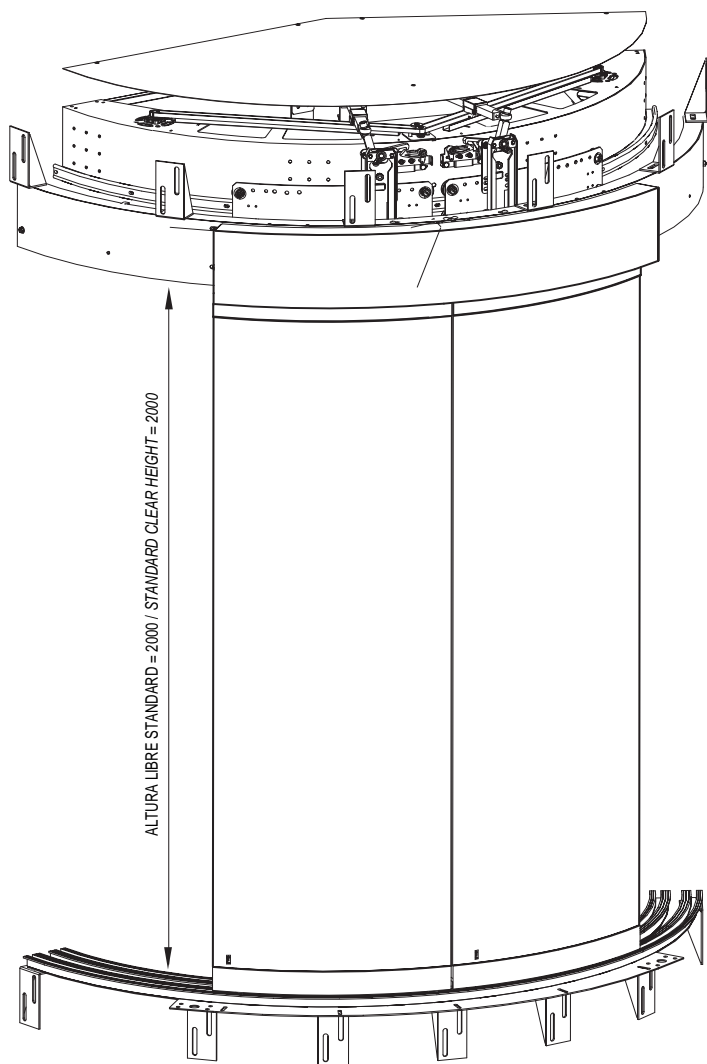

Puerta circular sin marco (puerta de rellano)
Round door without frame (landing door)

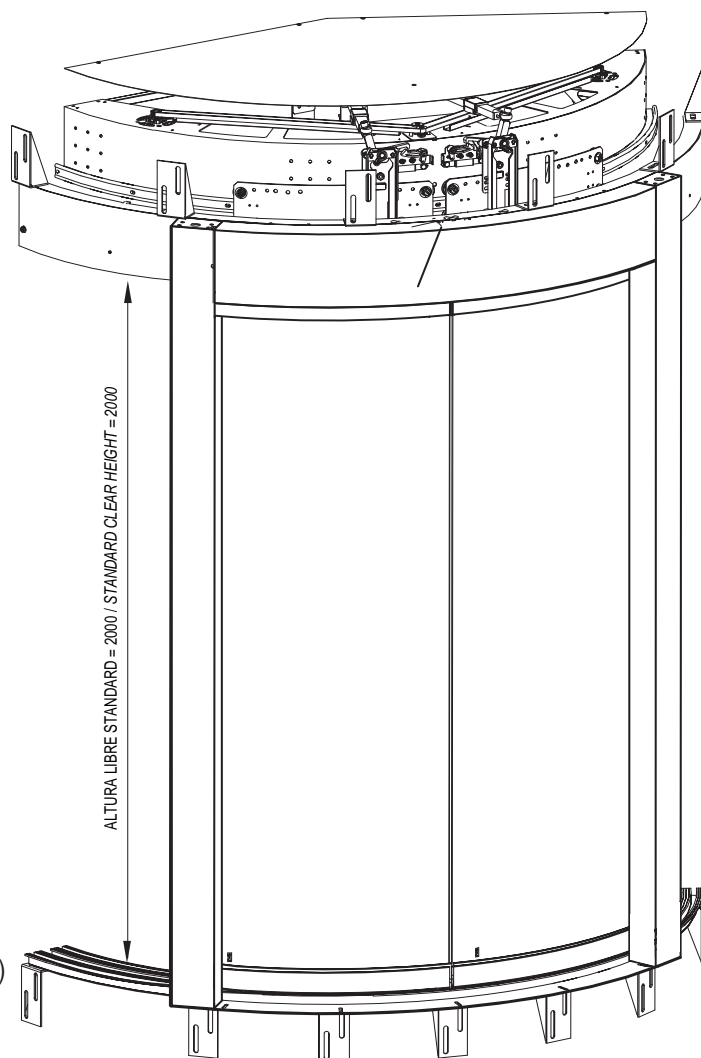

Puerta circular con marco (puerta de rellano)
Round door with frame (landing door)

Díámetro mínimo / *minimun diameter* = 1400

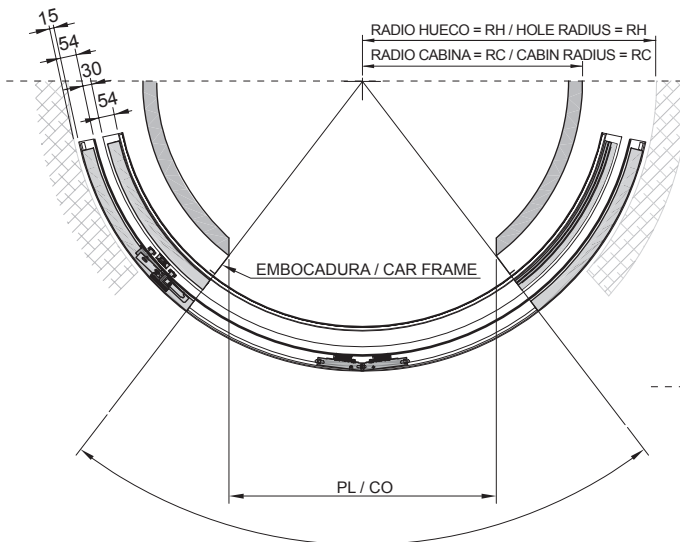
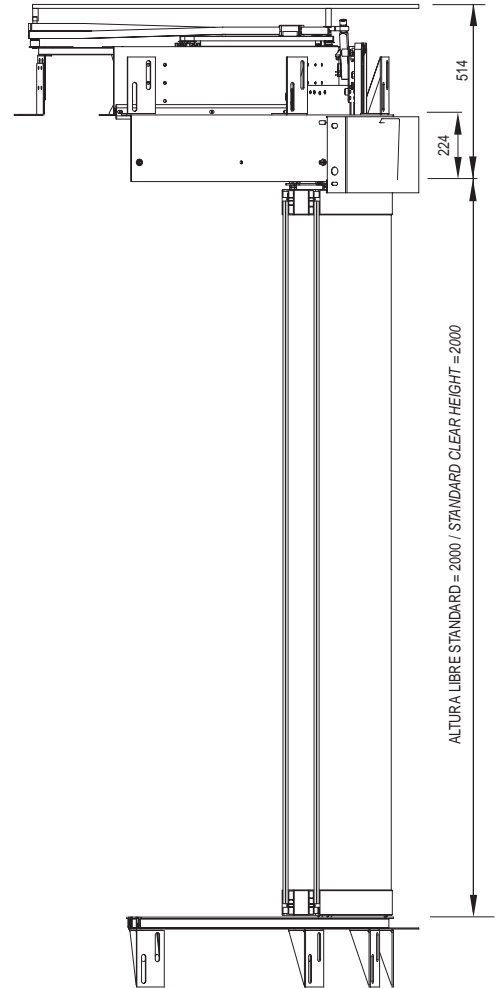
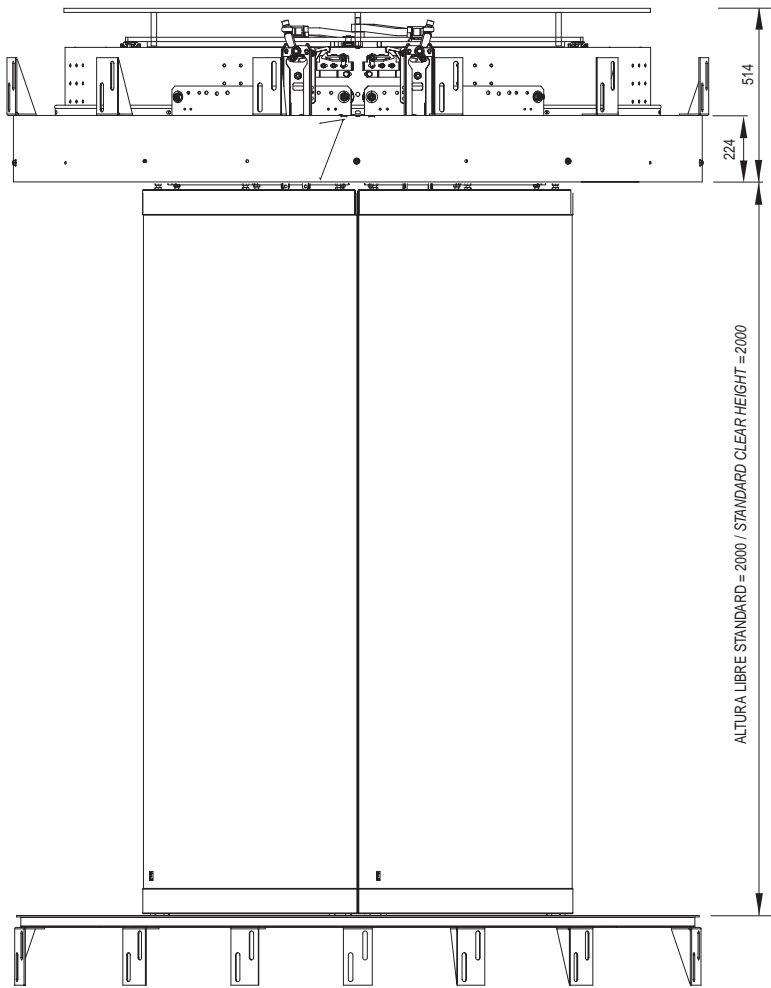

Puerta circular sin marco
Round door without frame

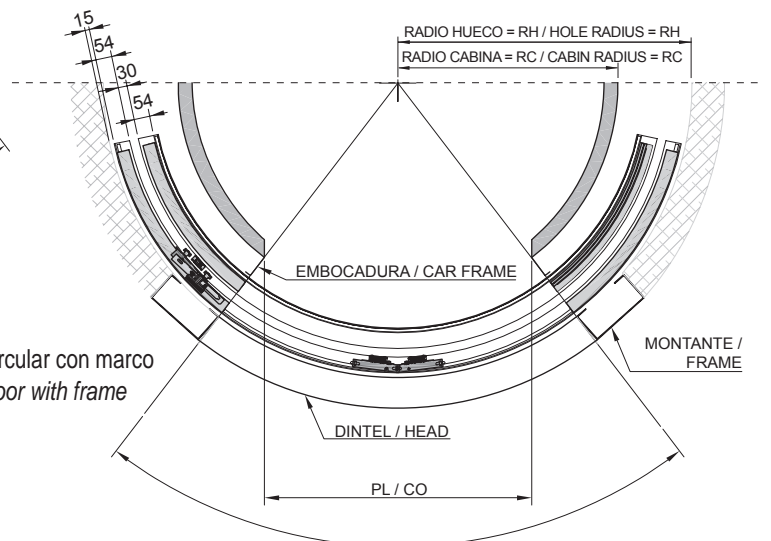

Puerta circular con marco
Round door with frame

RH MINIMO / MINIMUM RH = 700mm.
RC MÁXIMO / MAXIMUM RC = RH - 153mm.

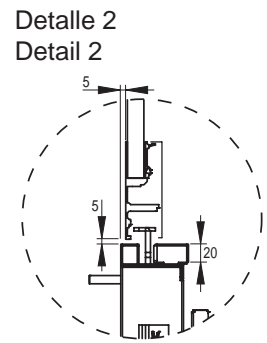
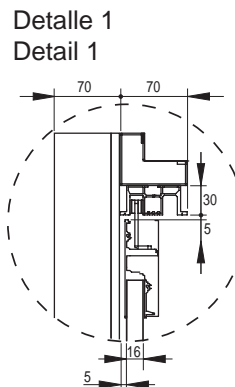
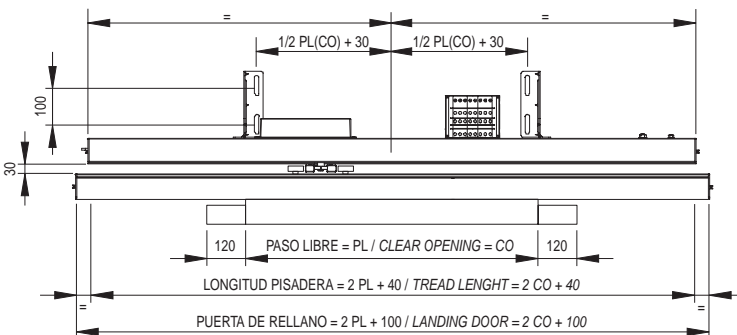
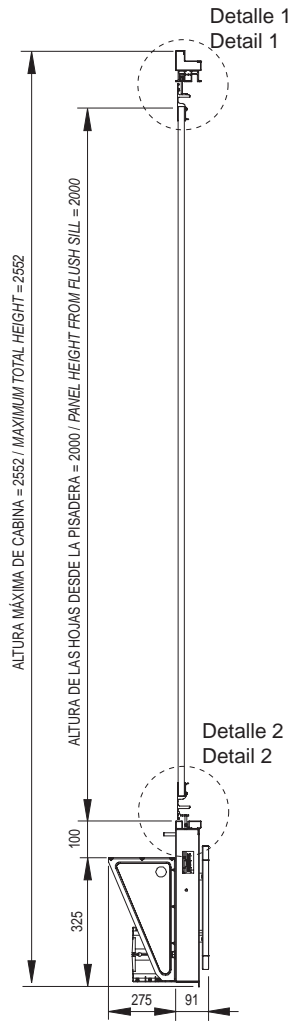
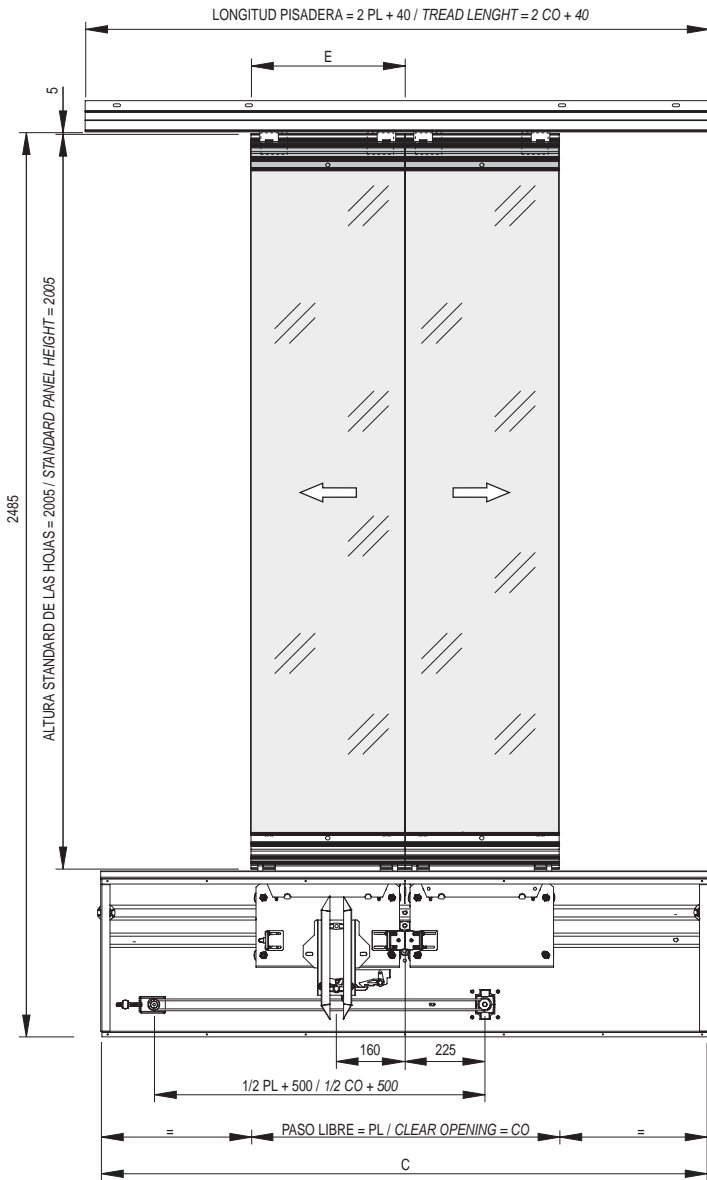

| PL / CO | 600 | 650 | 700 | 750 | 800 | 850 | 900 | 1000 | 1100 | 1200 |
|--------------------|-------|-------|--------|--------|--------|--------|--------|--------|--------|--------|
| C | 1250 | 1350 | 1450 | 1550 | 1650 | 1750 | 1850 | 2050 | 2250 | 2450 |
| E | 320 | 345 | 370 | 395 | 420 | 445 | 470 | 520 | 570 | 620 |
| PESO / WEIGHT (kg) | 88'13 | 95'46 | 102'81 | 110'16 | 117'50 | 124'84 | 132'19 | 146'88 | 161'56 | 176'25 |

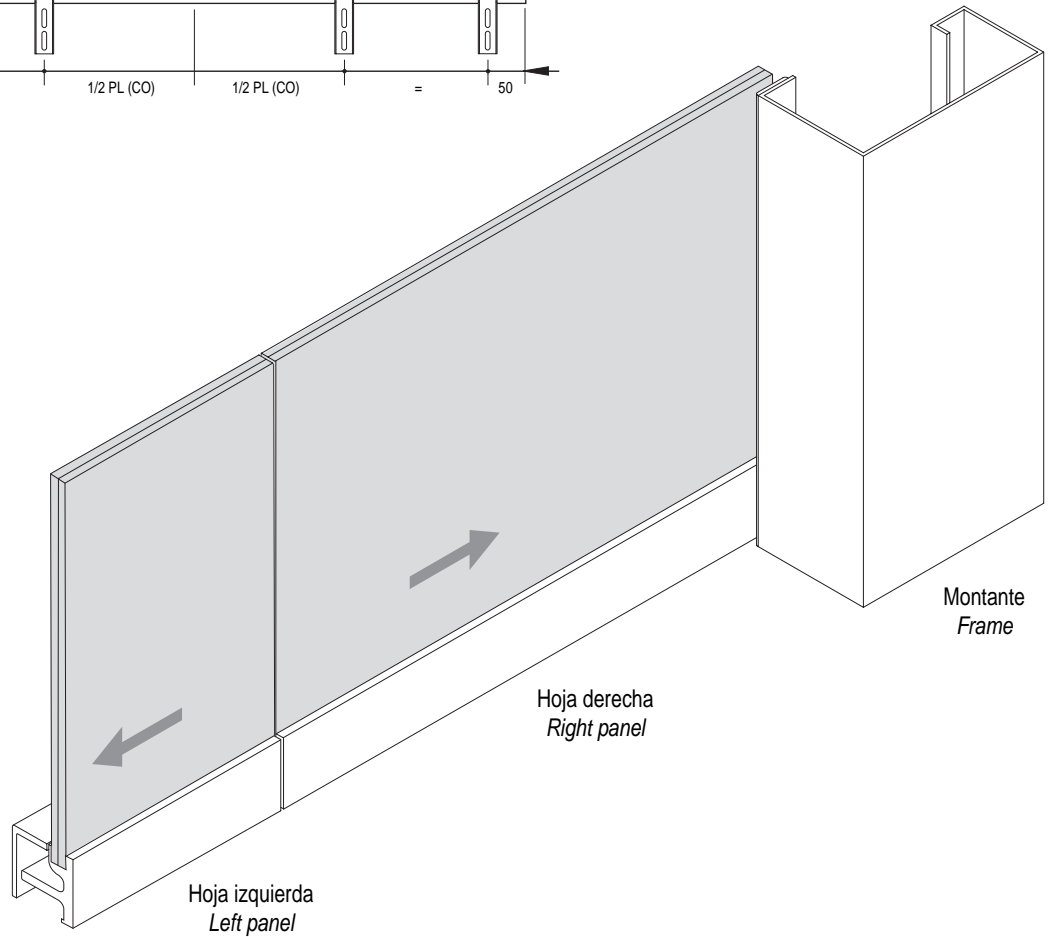
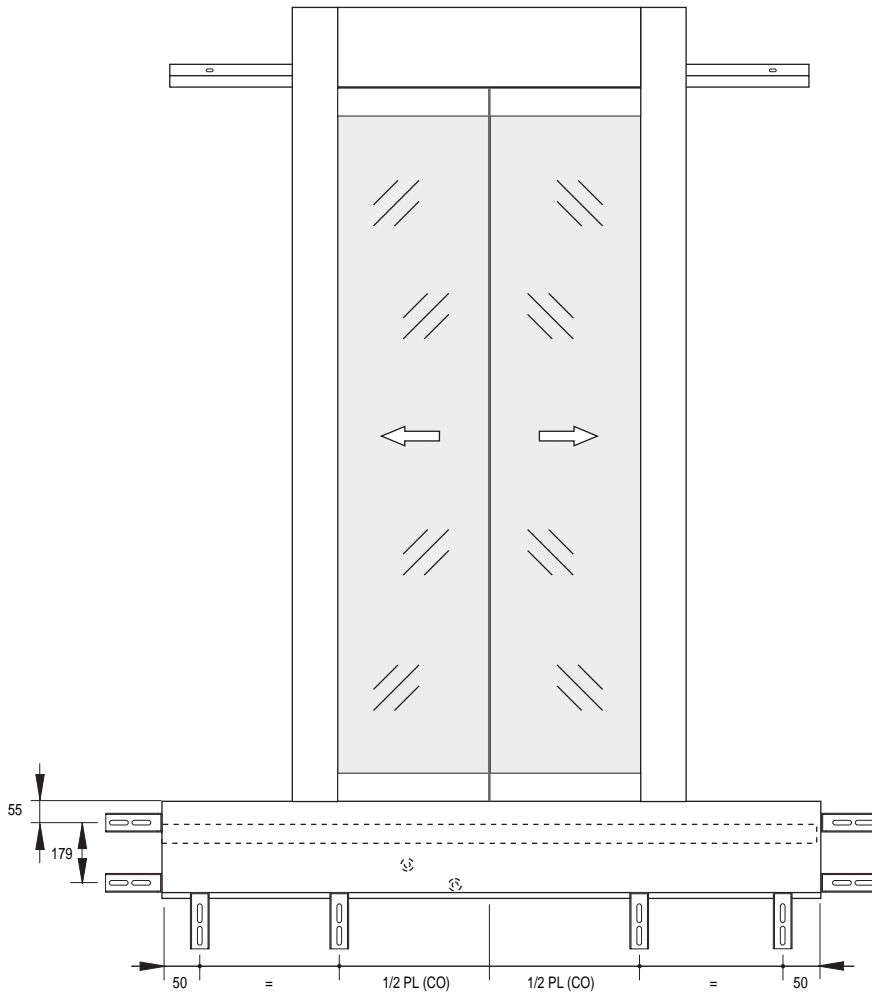

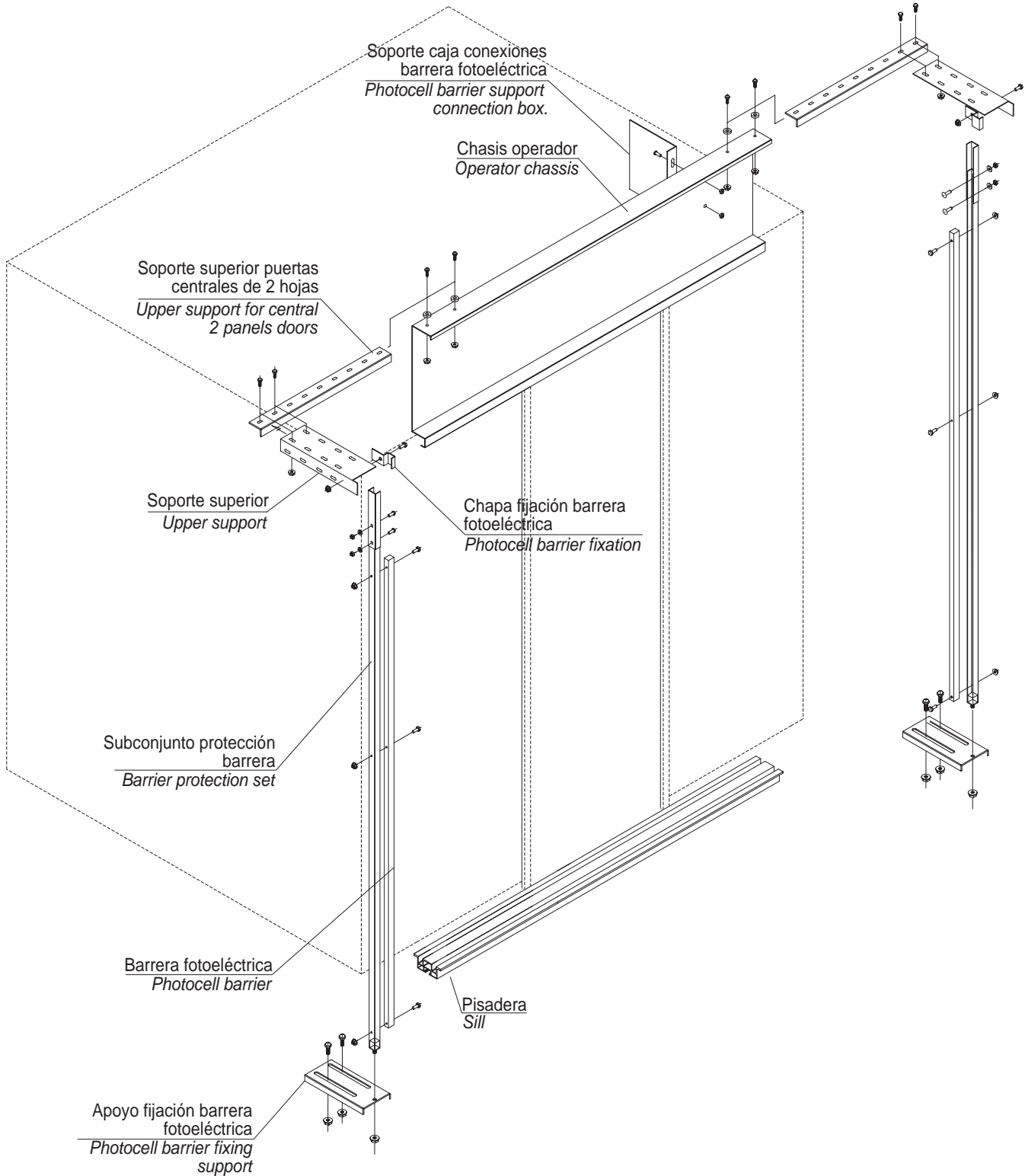

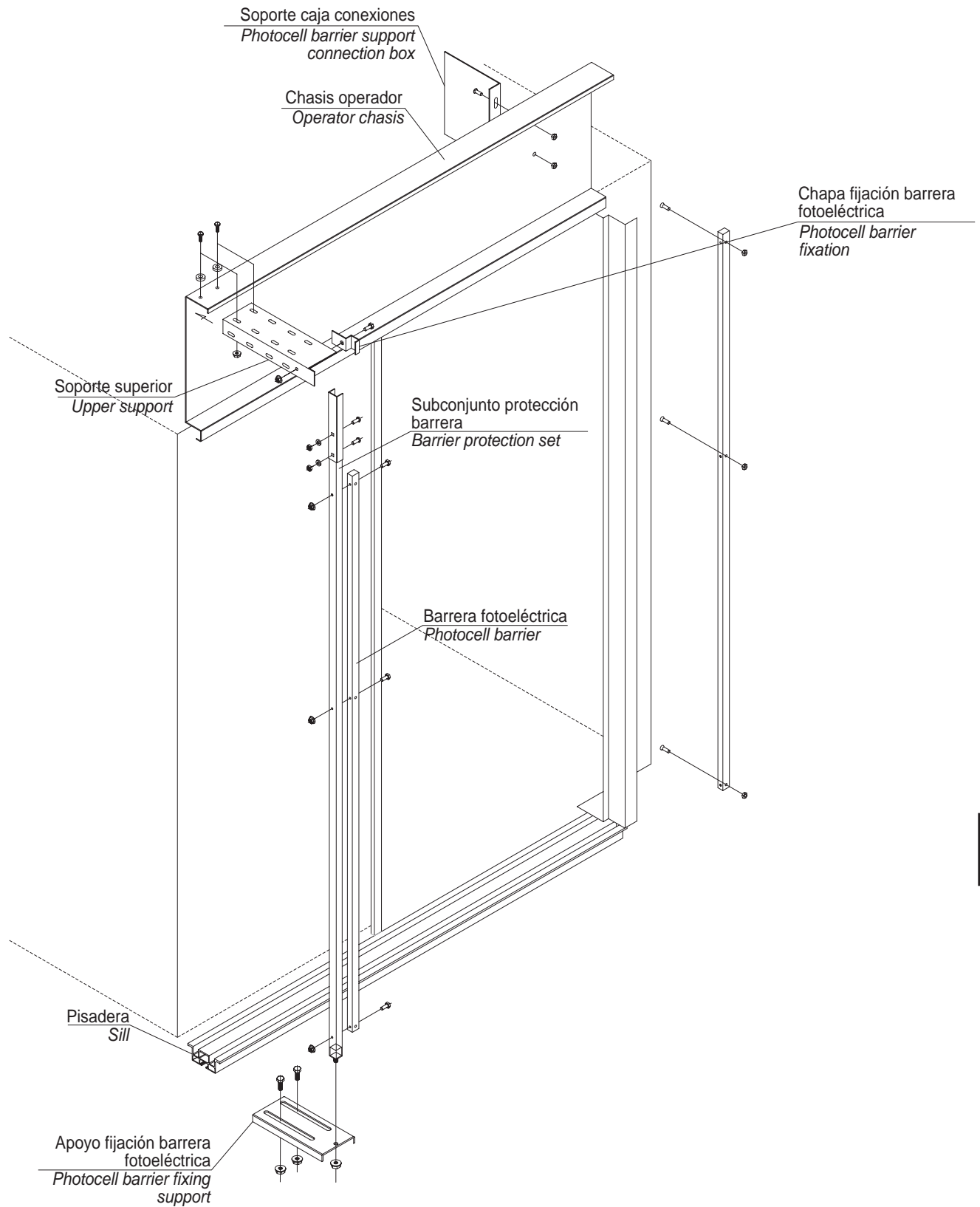

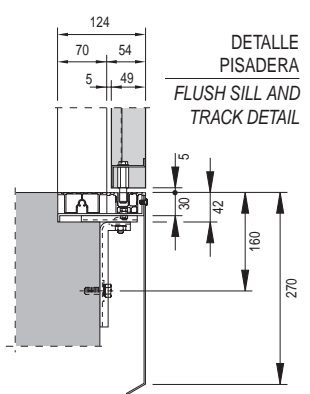
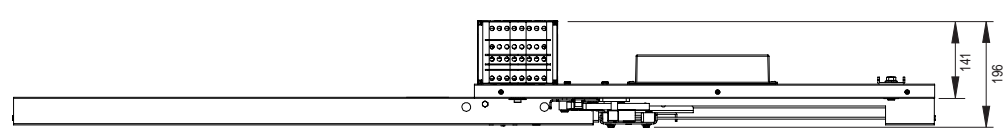
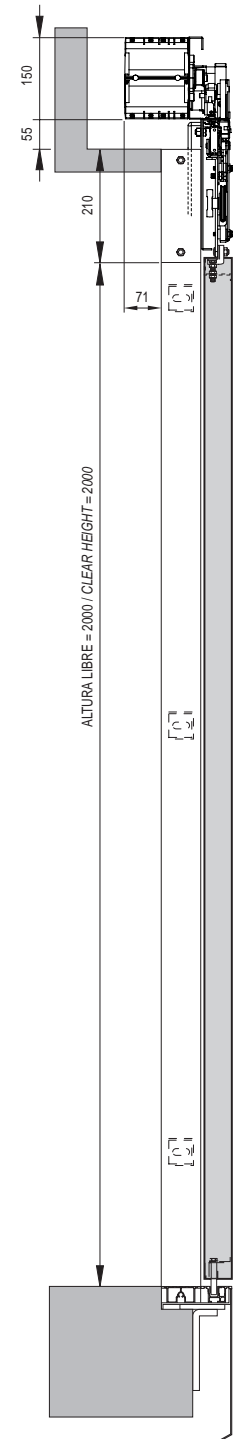
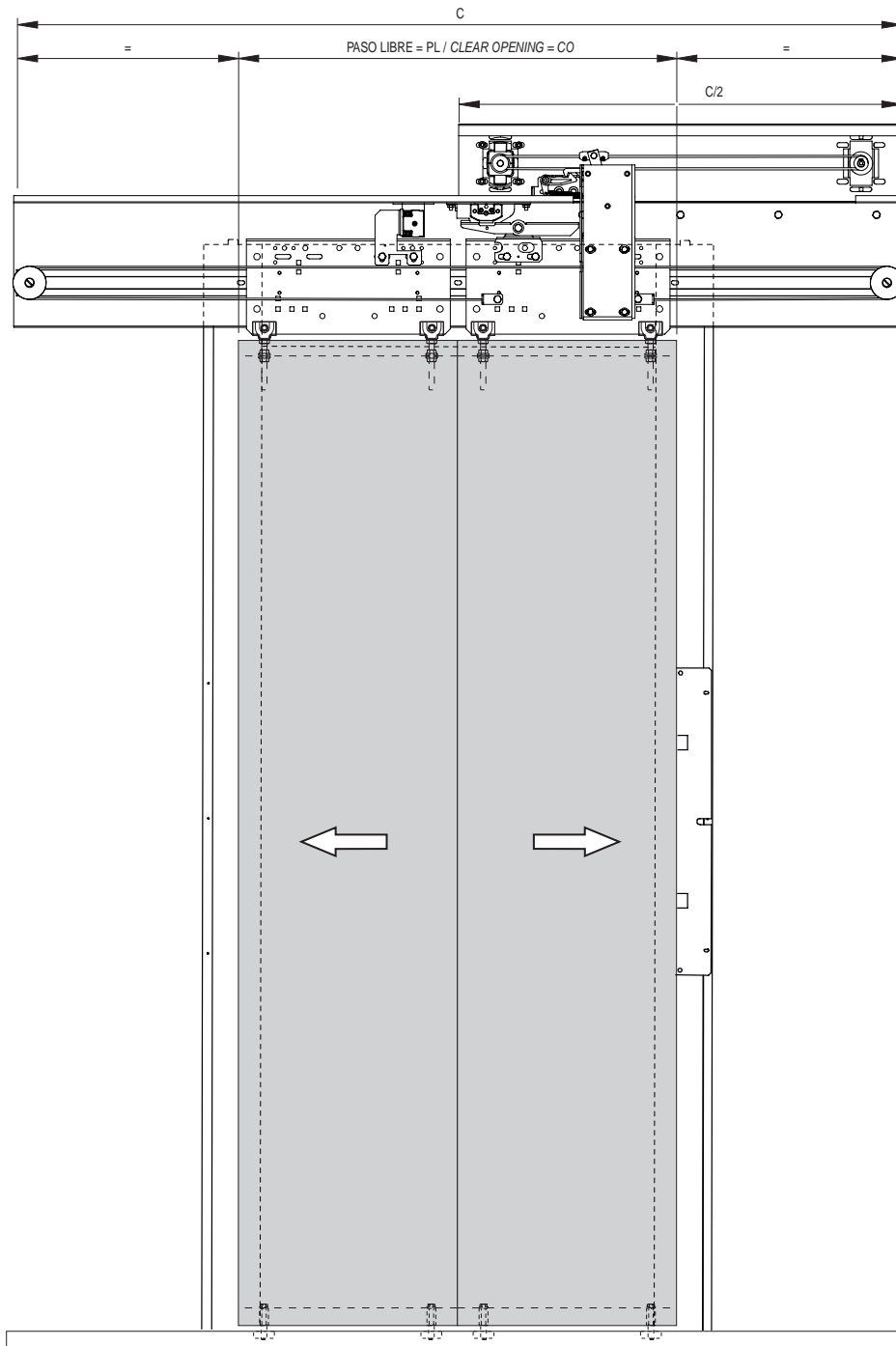

Se muestra modelo C2. Disponible también para cualquier número de hojas y para apertura central o telescópica. Para más información consultar con nuestro departamento técnico.

C2 model is shown. Also available for any number of panels and for side opening or centre parting doors. Ask with our technical department for more information.

| | | | | | | | | | | | | | | | | | | |
|---------|------|------|------|------|------|------|------|------|------|------|------|------|------|------|------|------|------|------|
| PL / CO | 600 | 650 | 700 | 750 | 800 | 850 | 900 | 1000 | 1100 | 1200 | 1300 | 1400 | 1500 | 1600 | 1700 | 1800 | 1900 | 2000 |
| C | 1300 | 1400 | 1500 | 1600 | 1700 | 1800 | 1900 | 2100 | 2300 | 2500 | 2700 | 2900 | 3100 | 3300 | 3500 | 3700 | 3900 | 4100 |

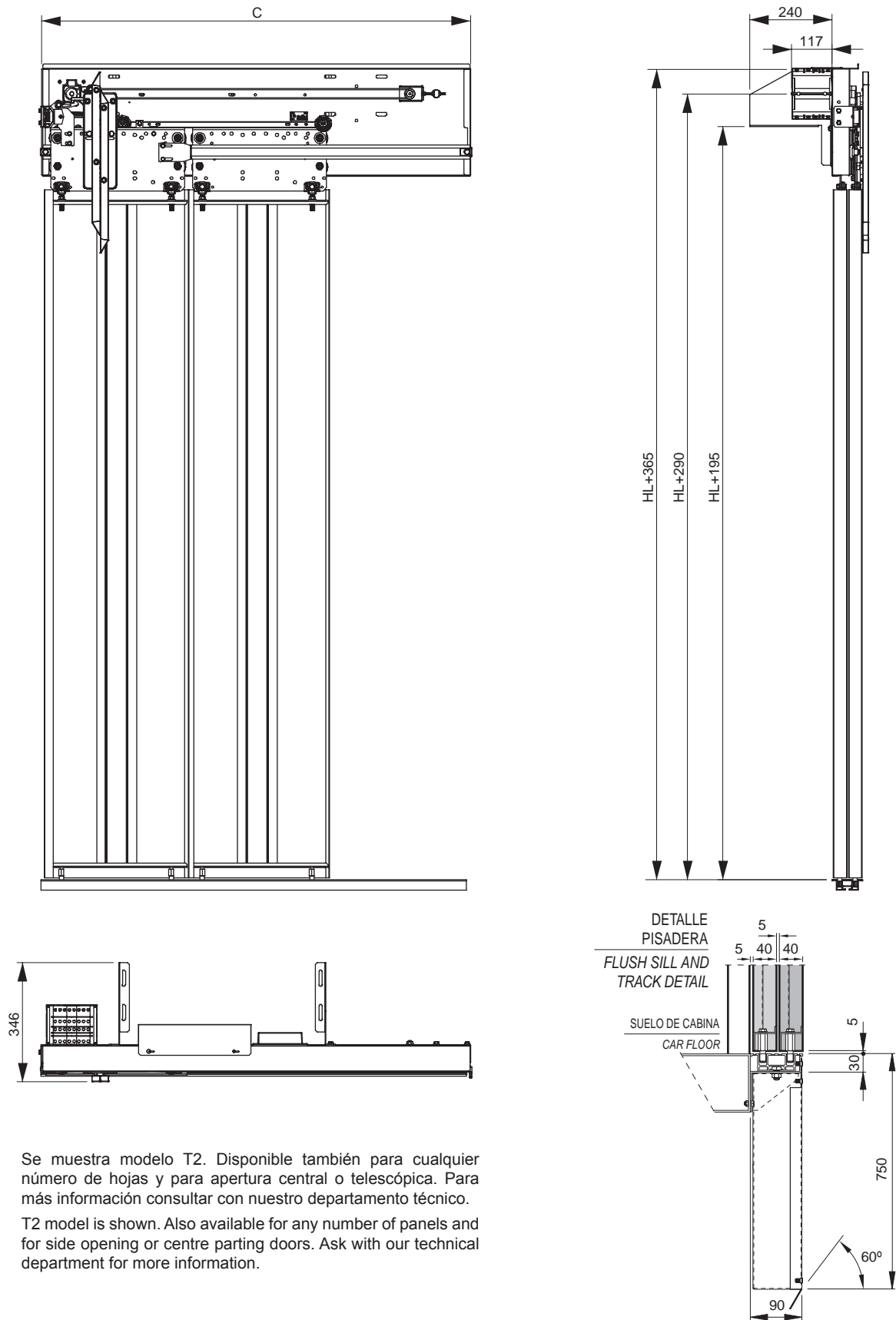

Se muestra modelo T2. Disponible también para cualquier número de hojas y para apertura central o telescópica. Para más información consultar con nuestro departamento técnico.
T2 model is shown. Also available for any number of panels and for side opening or centre parting doors. Ask with our technical department for more information.

| | | | | | | | | | | | | | | |
|---------|-----|------|------|------|------|------|------|------|------|------|------|------|------|------|
| PL / CO | 600 | 650 | 700 | 750 | 800 | 850 | 900 | 1000 | 1100 | 1200 | 1300 | 1400 | 1500 | 1600 |
| C | 950 | 1025 | 1100 | 1175 | 1250 | 1325 | 1400 | 1550 | 1700 | 1850 | 2000 | 2150 | 2300 | 2450 |

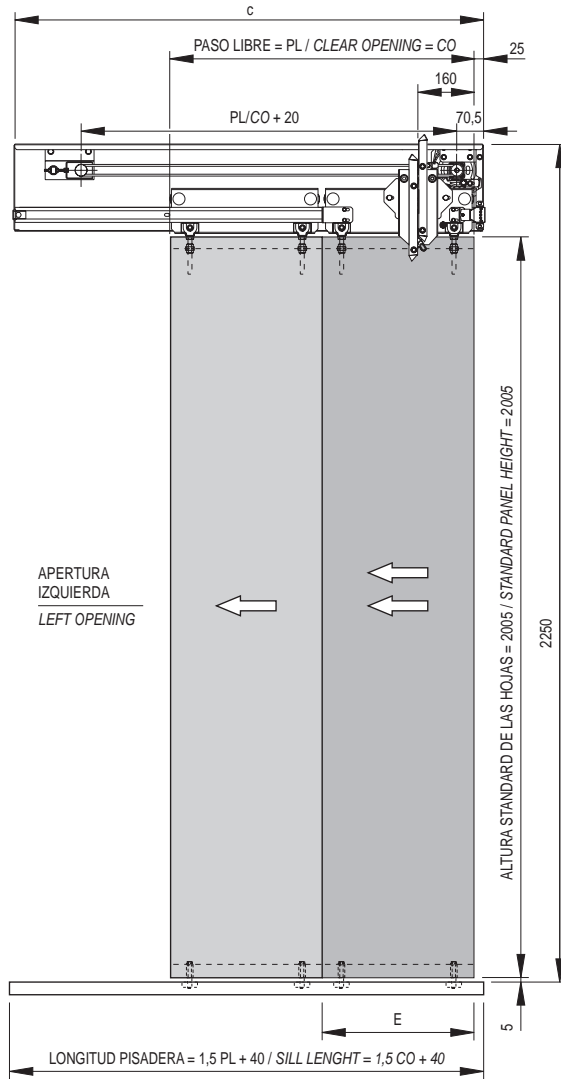

ESPACIO MÍNIMO DE LA EMBOCADURA = 50
MINIMUM SPACE ENTRANCE = 50

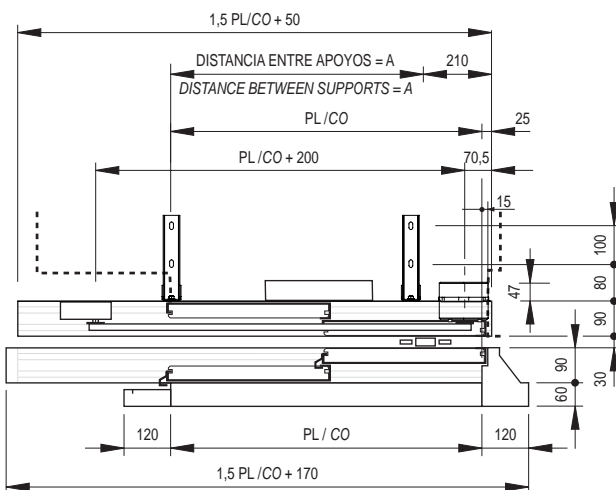
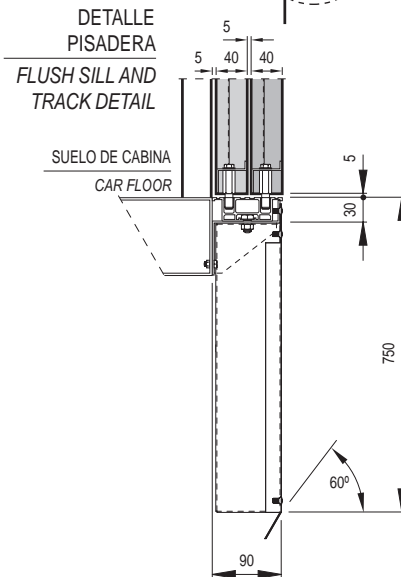
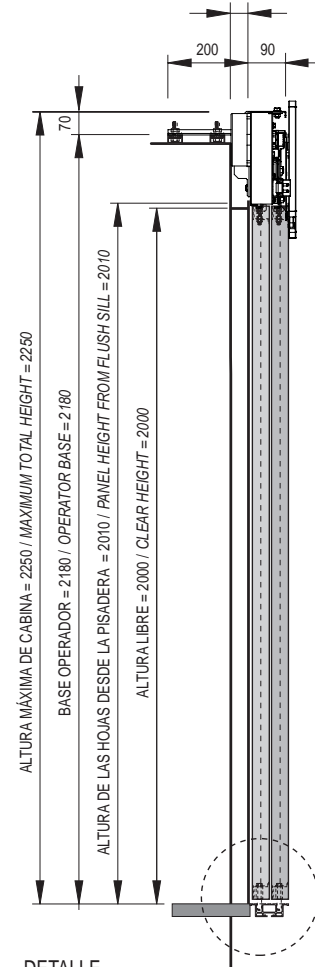

| PL / CO | 600 | 650 | 700 | 750 | 800 | 850 | 900 | 1000 | 1100 | 1200 | 1300 | 1400 | 1500 | 1600 |
|--------------------|------|------|------|------|------|------|------|------|------|------|------|-------|-------|------|
| A | 445 | 495 | 545 | 595 | 645 | 695 | 745 | 845 | 945 | 1045 | 1145 | 1245 | 1345 | 1445 |
| C | 950 | 1025 | 1100 | 1175 | 1250 | 1325 | 1400 | 1550 | 1700 | 1850 | 2000 | 2150 | 2300 | 2450 |
| E | 320 | 345 | 370 | 395 | 420 | 445 | 470 | 520 | 570 | 620 | 670 | 720 | 770 | 820 |
| TIEMPO / TIME (s) | 1,56 | 1,62 | 1,68 | 1,74 | 1,8 | 1,85 | 1,91 | 2,01 | 2,11 | 2,2 | 2,3 | 2,4 | 2,5 | 2,6 |
| PESO / WEIGHT (kg) | 52,5 | 57 | 61,5 | 66 | 70 | 74,5 | 79 | 87,5 | 96,5 | 105 | 114 | 122,5 | 131,5 | 140 |

Nuevo modelo de puerta "MSS" ideal para proyectos de modernización, con un marco especial reducido y montantes a nivel del suelo para facilitar su montaje. Del mismo modo, gracias a su innovador diseño no requiere el montaje de suplemento de pisadera.

The "MSS" door model has been specially designed for modernization projects, with a special reduced frame and vertical posts located at floor level to facilitate its installation. Thanks to its innovative design, it does not require to use a supplementary sill between frames.

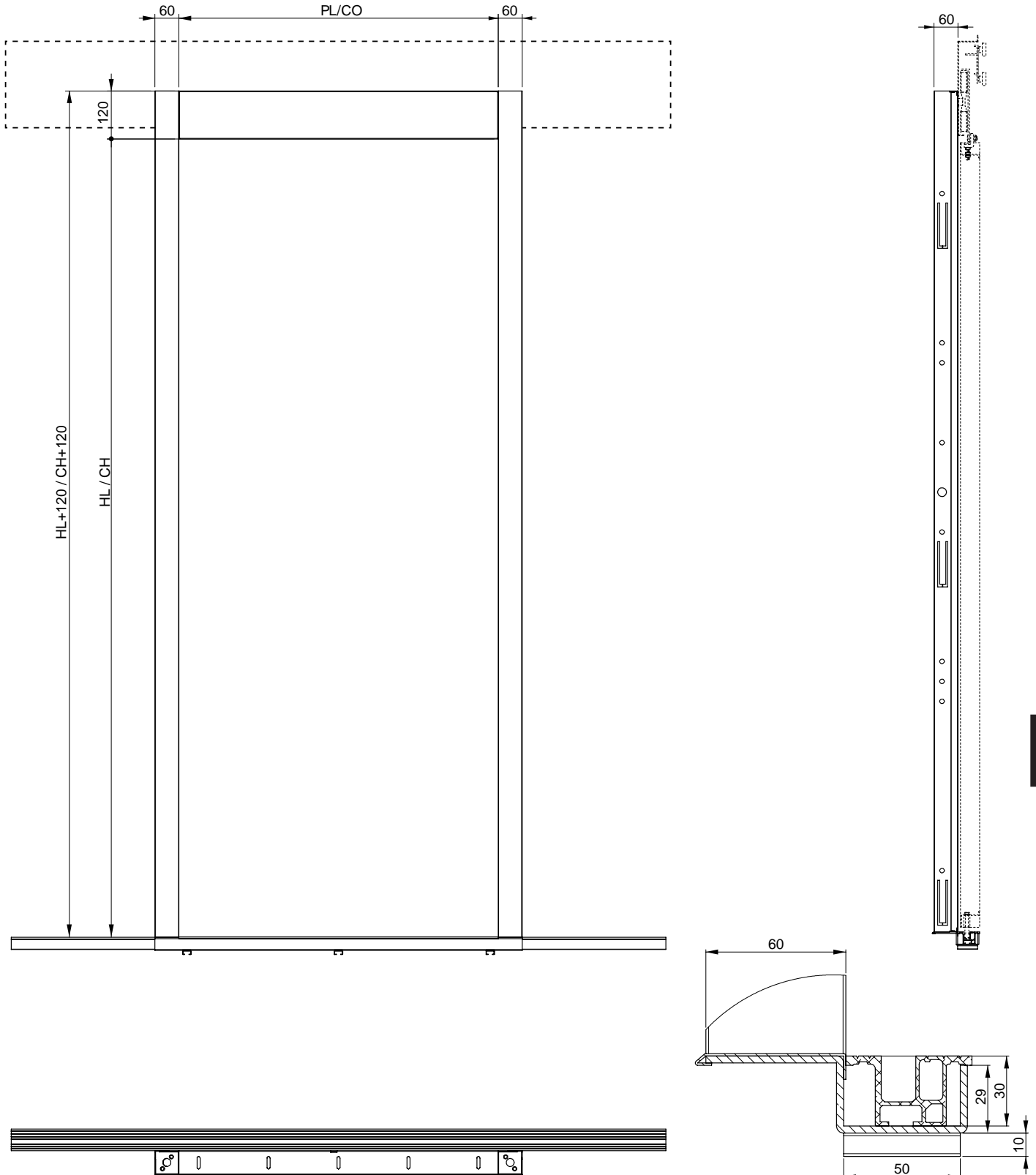

El módulo de puertas de ascensor VVVF 4+ es un equipo de control basado en un variador de tensión/frecuencia específico, que integra además todo lo necesario para controlar una puerta de ascensor de cualquier tipo. Todo el sistema está diseñado para adaptar y trabajar con cualquier maniobra existente en el mercado y así mismo ofrecer seguridad, fiabilidad y confort en su funcionamiento.

The module for the VVVF 4+ of doors for lifts is an equipment control based in a specific mixer of tension/frequency which also integrates all the necessary in order to control any type of lift door. All system is designed to be adapted and work with any existent manoeuvre in the market offering full security, reliability and comfort during its operation.

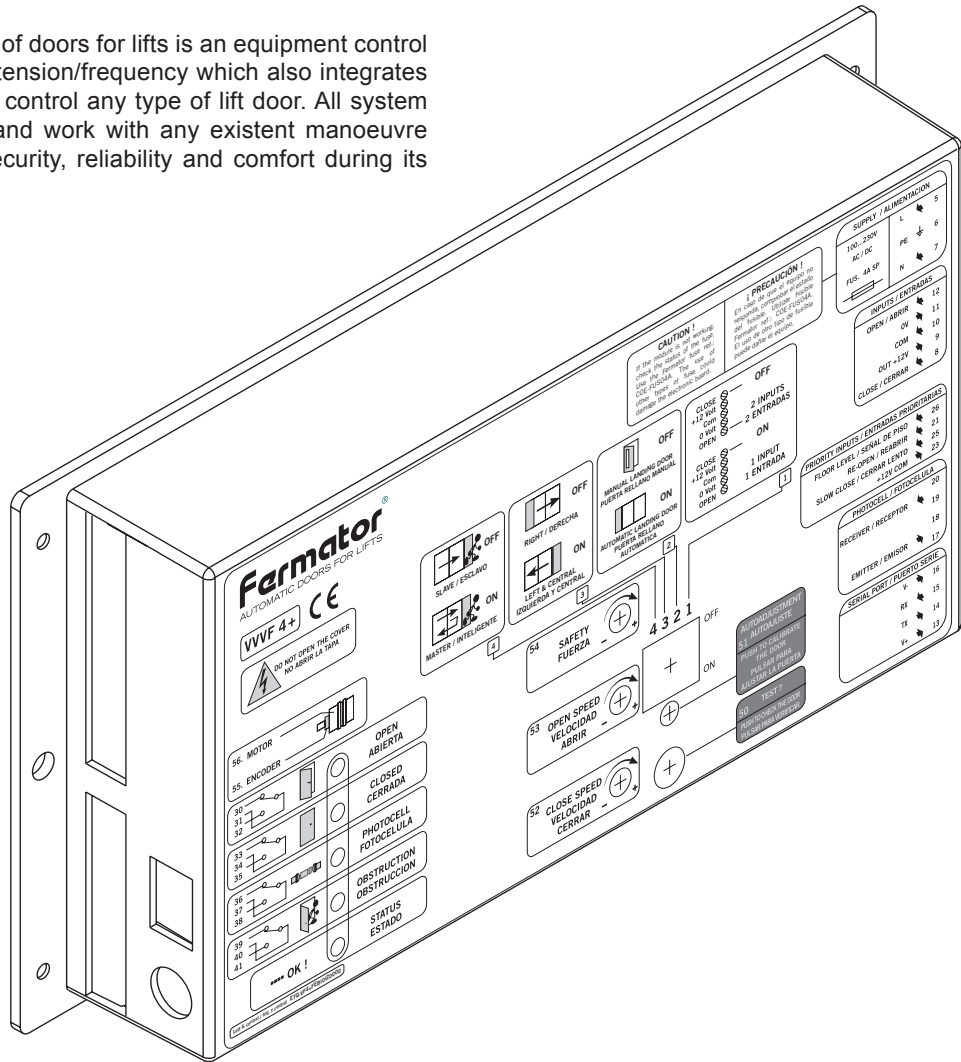

PRECAUCIÓN: CONEXIÓN A 230 VAC. - CAUTION: CONNECTION AT 230 VAC.

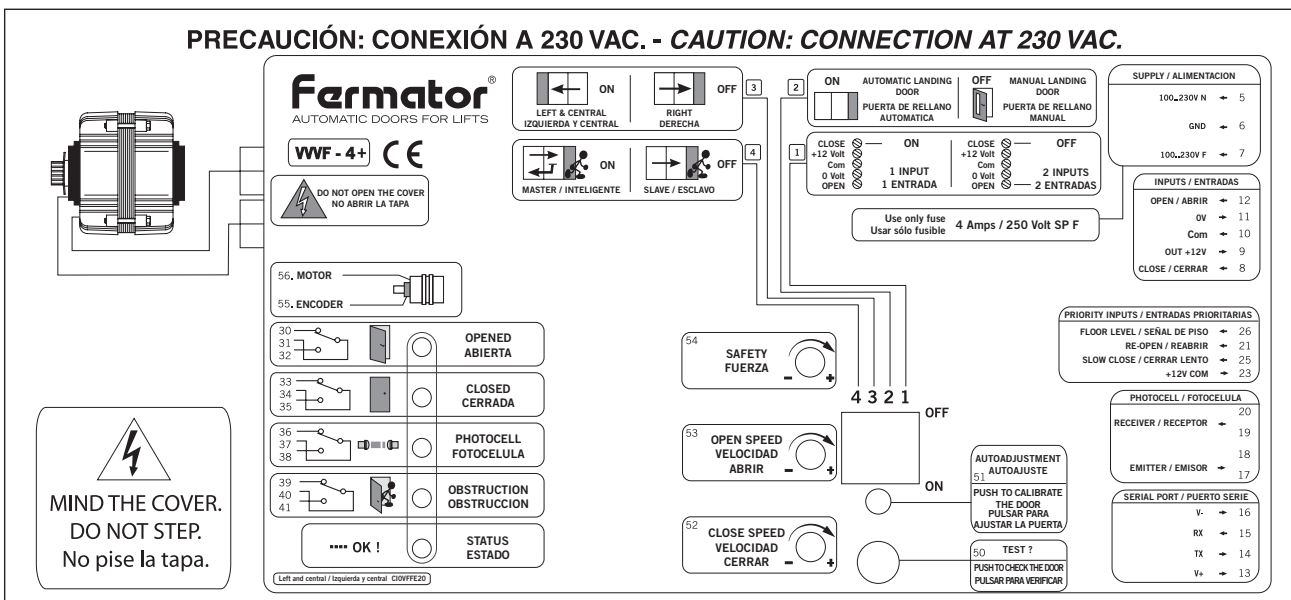

Para todo tipo de puertas de rellano automáticas
For all type of automatic landing doors

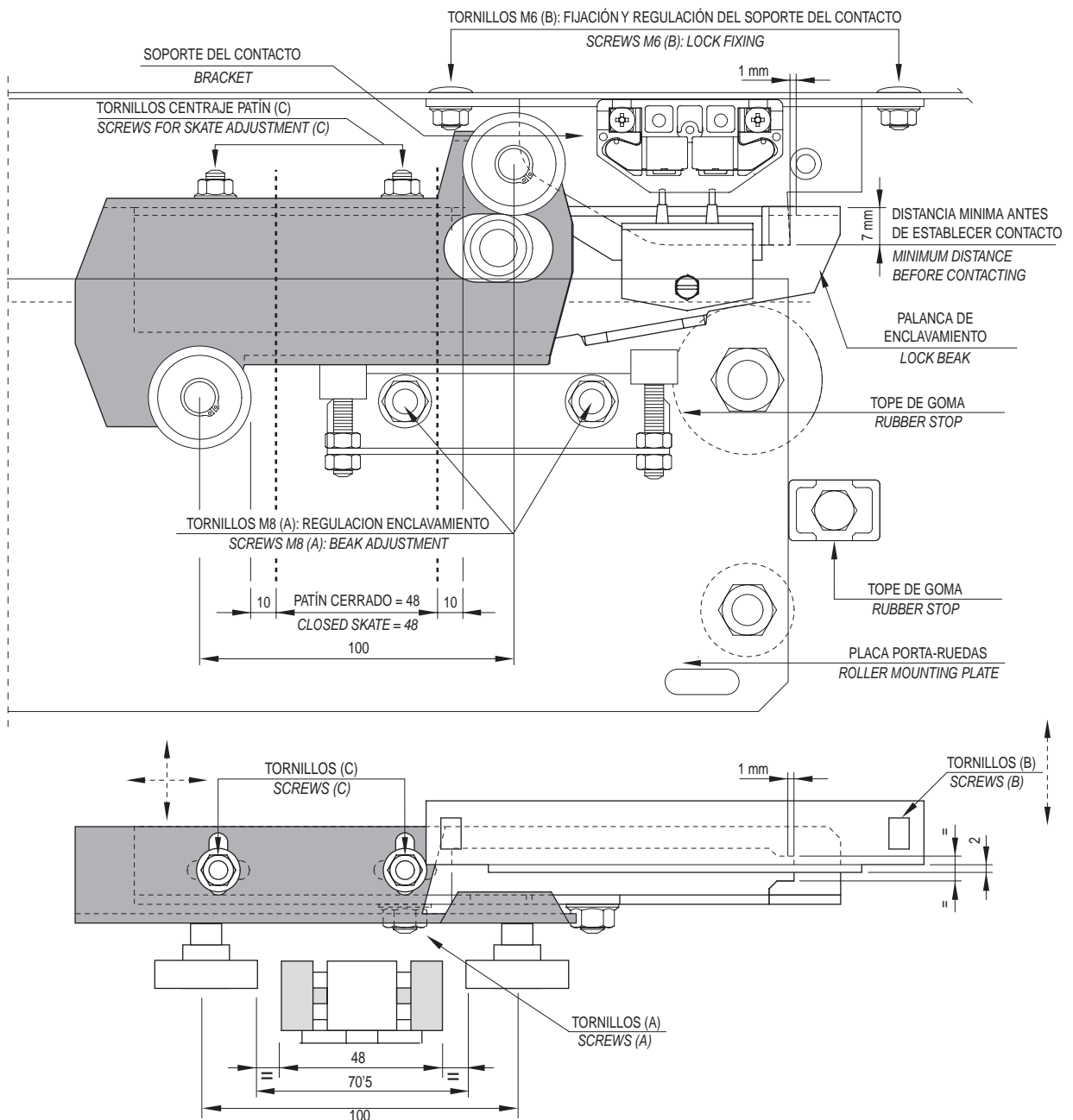

REGULACION DEL SISTEMA DE ENCLAVAMIENTO DE LA PUERTA DE RELLANO

- Mediante la regulación de los 2 tornillos M8 (A), debe conseguirse una holgura de 1 mm entre el soporte del contacto y la palanca de enclavamiento.
- Mediante la regulación de los 2 tornillos M6 (B), debe regularse la posición del contacto, respecto al puente eléctrico situado en la palanca de enclavamiento.
- La regulación de los tornillos (C), nos permitirá ajustar la posición correcta de las ruedas, respecto al patín móvil. Mediante estos tornillos disponemos de regulación en sentido interior-exterior y derecha-izquierda en sentido lateral.

LANDING DOOR LOCK REGULATION

- By adjusting the 2 screws M8 (A), a clearance of 1 mm must be achieved between the lock beak and the lock contact support bracket when the lock is fully engaged.
- The regulation between the position of the contact and electric bridge placed in lock beak has to be done with screws M6 (B).
- The regulation (C) will allow us to adjust the correct position of the wheels with respect to the skate. With this regulation we have the possibility to adjust in the front, in the back and laterally to the right and to the left.

Para todo tipo de puertas de rellano automáticas
For all type of automatic landing doors

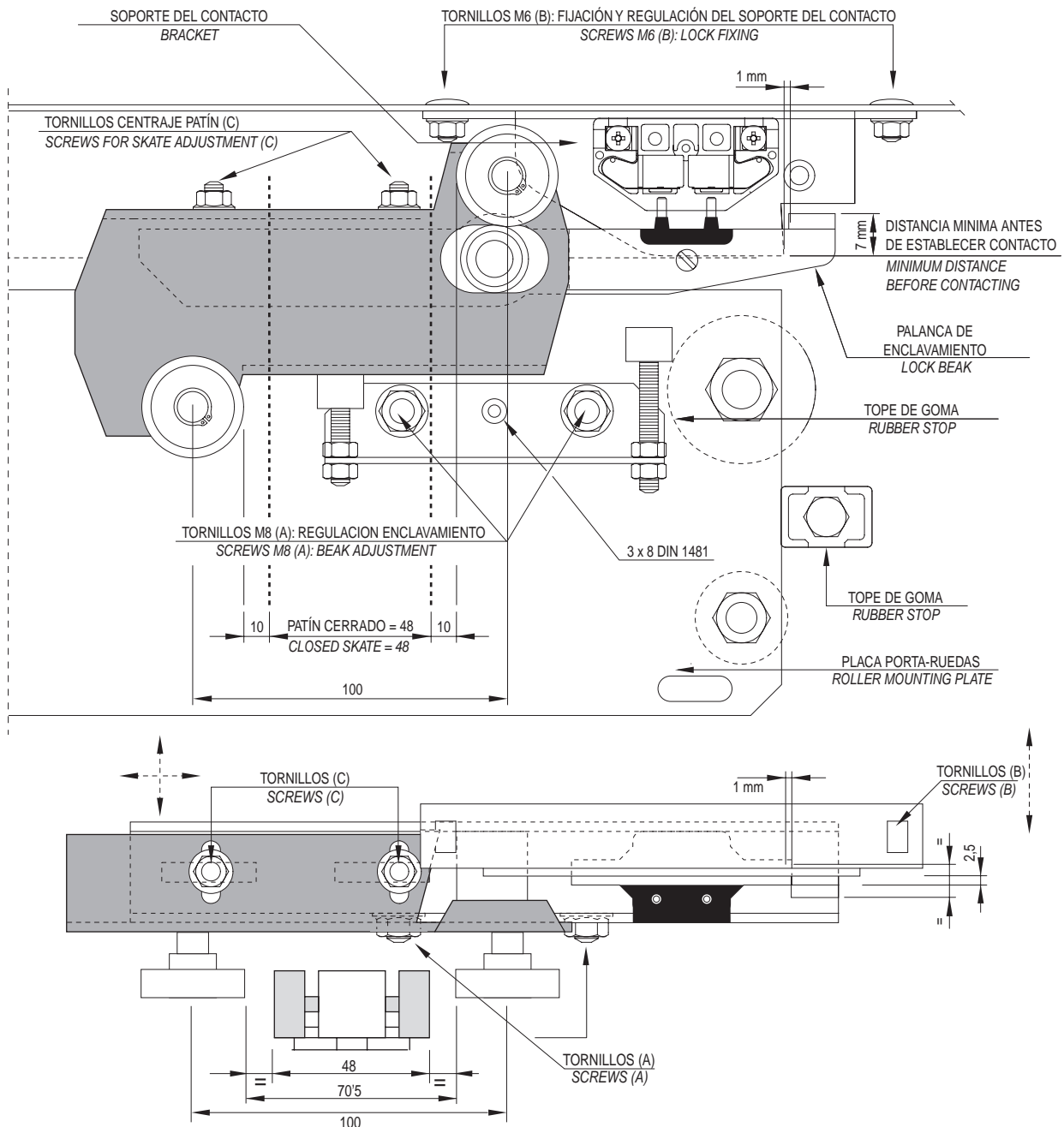

REGULACION DEL SISTEMA DE ENCLAVAMIENTO DE LA PUERTA DE RELANO

- Mediante la regulación de los 2 tornillos M8 (A), debe conseguirse una holgura de 1 mm. entre el soporte del contacto y la palanca de enclavamiento.
- Mediante la regulación de los 2 tornillos M6 (B), debe regularse la posición del contacto, respecto al puente eléctrico situado en la palanca de enclavamiento.
- La regulación de los tornillos (C), nos permitirá ajustar la posición correcta de las ruedas, respecto al patín móvil. Mediante estos tornillos disponemos de regulación en sentido interior-exterior y derecha-izquierda en sentido lateral.

LANDING DOOR LOCK REGULATION

- By adjusting the 2 screws M8 (A), a clearance of 1 mm. must be achieved between the lock beak and the lock contact support bracket when the lock is fully engaged.
- The regulation between the position of the contact and electric bridge placed in lock beak has to be done with screws M6 (B).
- The regulation (C) will allow us to adjust the correct position of the wheels with respect to the skate. With this regulation we have the possibility to adjust in the front, in the back and laterally to the right and to the left.

Fermator dispone de soluciones específicas para cualquier altura de cabina.
Fermator have specific solutions for any car height.

A: Patín desplazado 50mm.
A: 50mm. displaced skate

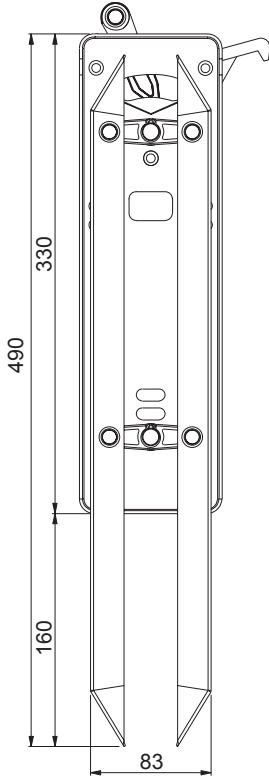

B: Patín desplazado 100mm.
B: 100mm. displaced skate

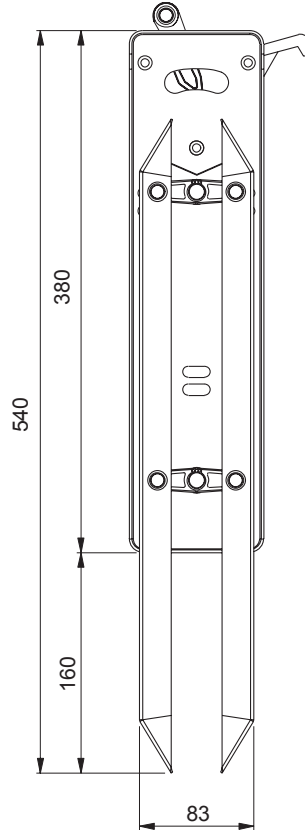

C: Patín desplazado 150mm.
C: 150mm. displaced skate

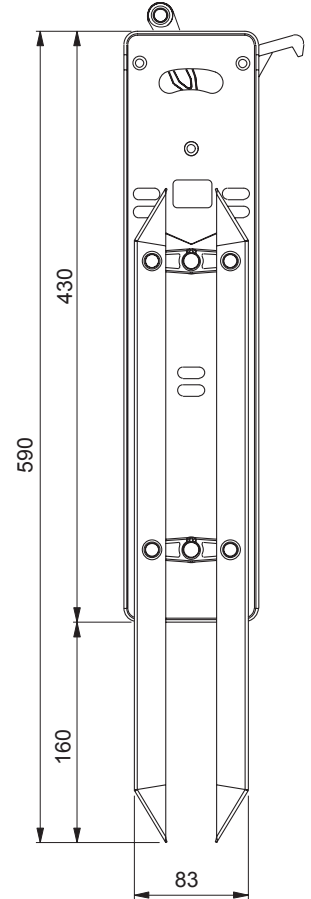

D: Patín modelo Q para desplazamientos superiores a 150 mm.
D: Q model skate for upper displacements than 150 mm.



Tabla de medidas:
Measures table:

| S | Patín Skate | X | Y | DS ⁽¹⁾ | Z |
|------|-------------|--------|-----|-------------------|------|
| 270 | A | --- | --- | --- | --- |
| 320 | B | --- | --- | --- | --- |
| 320 | D | 541,5 | 55 | +0 | 36,5 |
| 370 | C | --- | --- | --- | --- |
| 370 | D | 591,5 | 55 | +20 | 56,5 |
| 420 | | 641,5 | | +30 | 76,5 |
| 470 | | 691,5 | 105 | --- | --- |
| 520 | | 741,5 | 155 | --- | --- |
| 570 | | 791,5 | 205 | --- | --- |
| 620 | | 841,5 | 255 | --- | --- |
| 670 | | 891,5 | 305 | --- | --- |
| 720 | | 941,5 | 355 | --- | --- |
| 770 | | 991,5 | 405 | --- | --- |
| 820 | | 1041,5 | 455 | --- | --- |
| 870 | | 1091,5 | 505 | --- | --- |
| 920 | | 1141,5 | 555 | --- | --- |
| 970 | 1191,5 | 605 | --- | --- | |
| 1020 | 1241,5 | 655 | --- | --- | |
| 1070 | 1291,5 | 705 | --- | --- | |

(1) Desplazamiento horizontal / Horizontal displacement

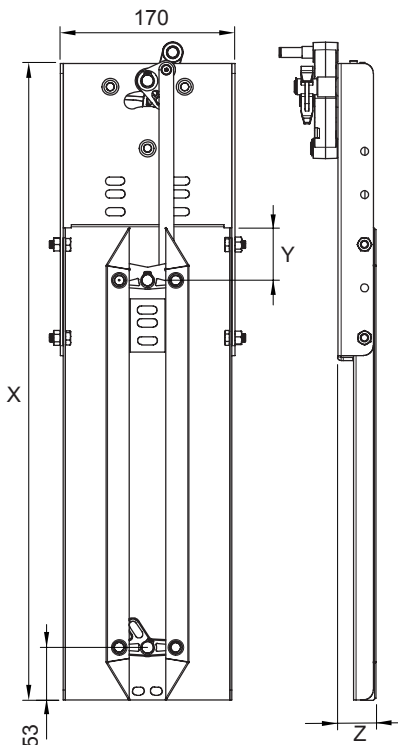
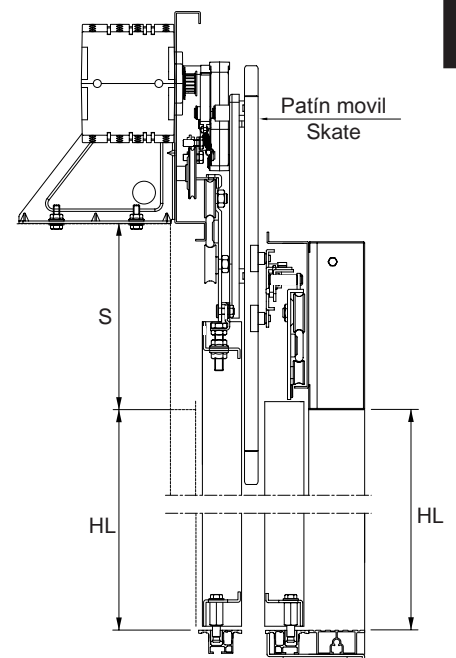

Distintas posiciones posibles del enclavamiento de cabina.
Different positions for car door lock.

ENCLAVAMIENTO DE CABINA PARA PUERTAS CENTRALES / CAR DOOR LOCK FOR CENTRAL PARTING DOORS

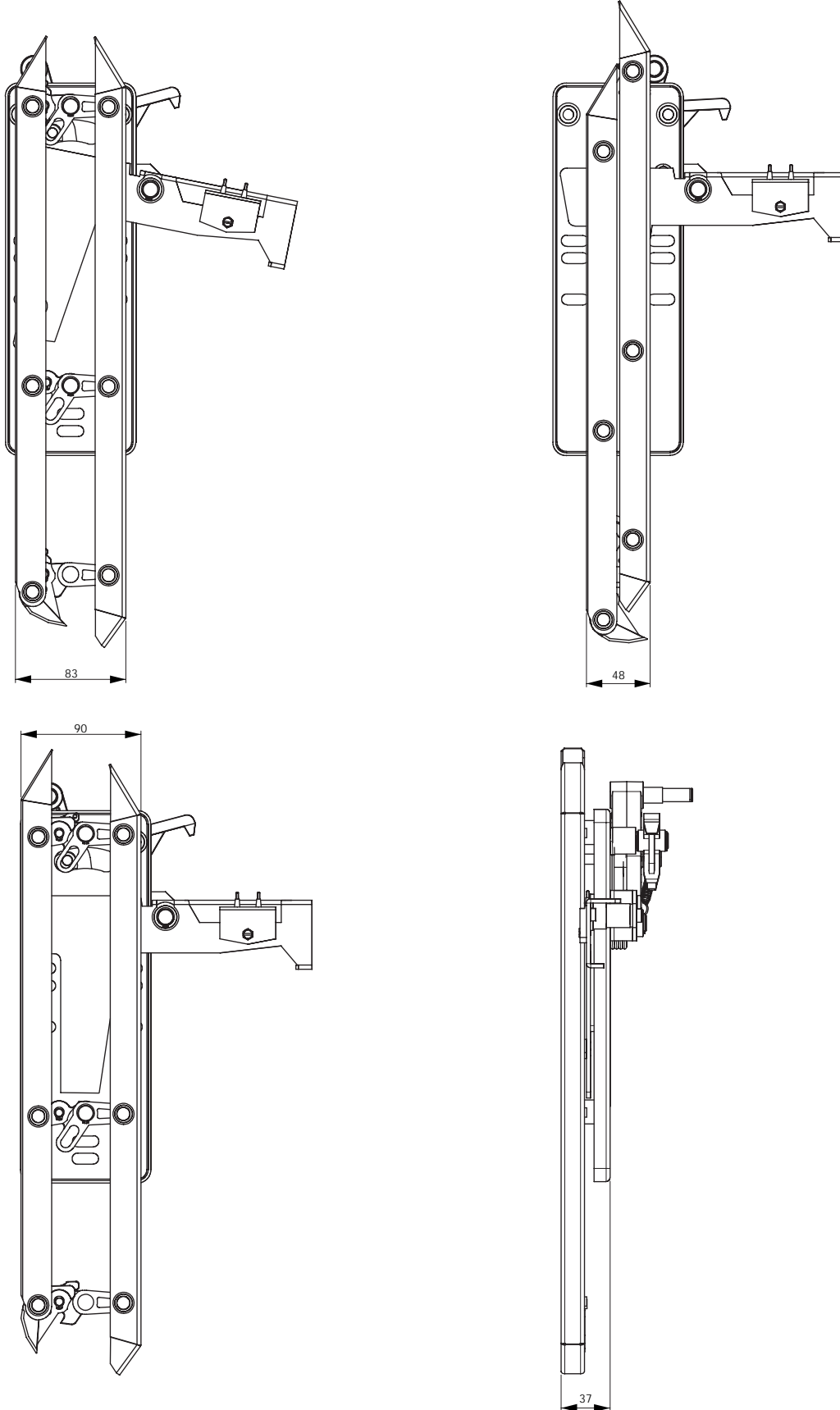

Distintas posiciones posibles del enclavamiento de cabina.
Different positions for car door lock.

ENCLAVAMIENTO DE CABINA PARA PUERTAS TELESCOPICAS / CAR DOOR LOCK FOR SIDE OPENING DOORS

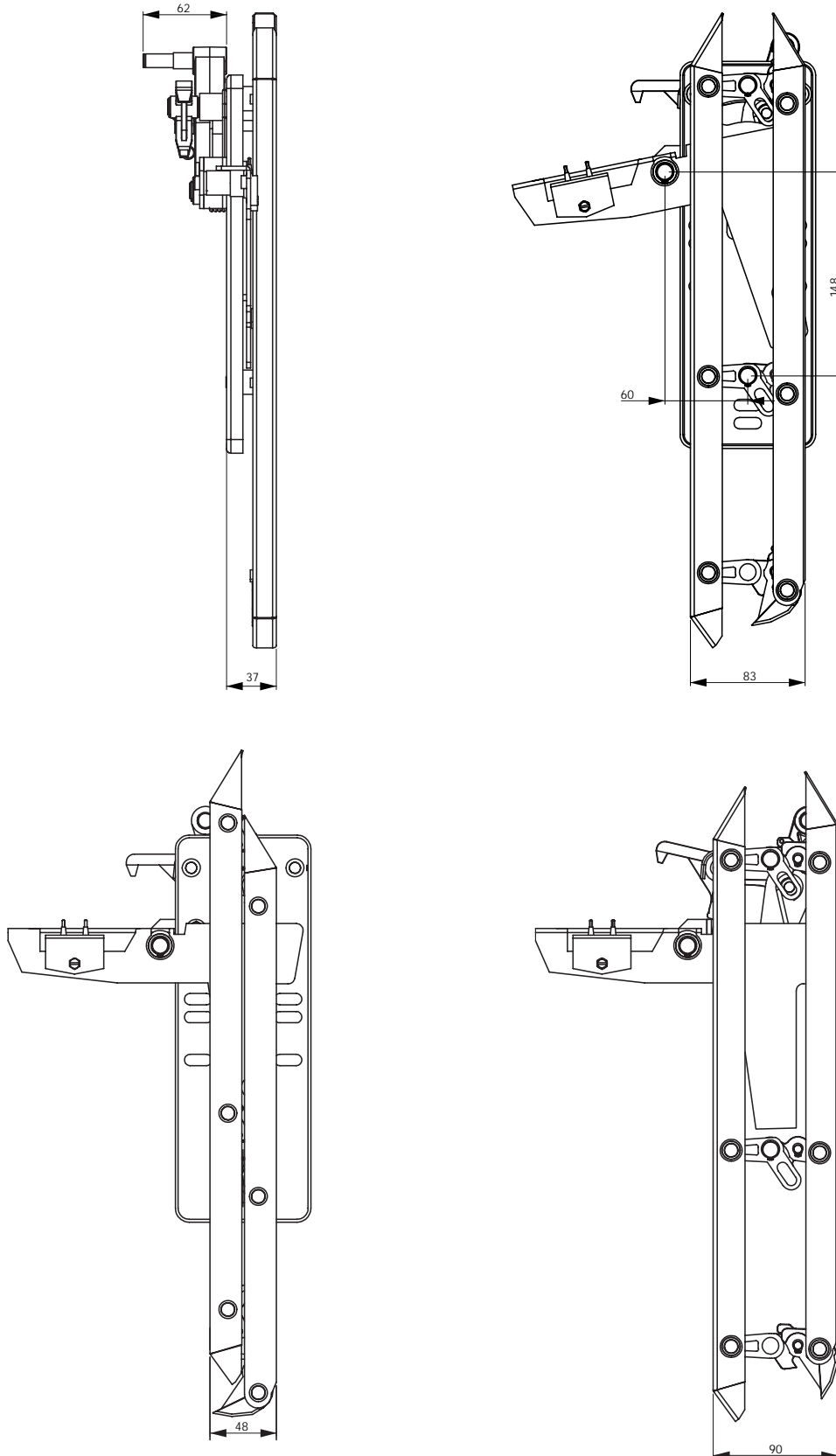

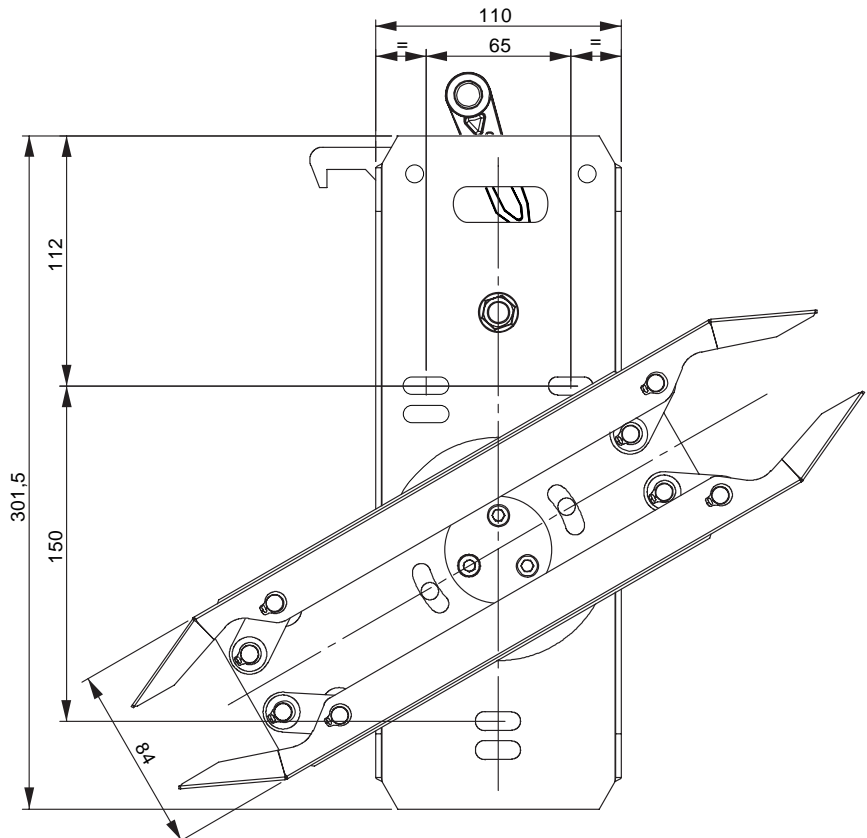
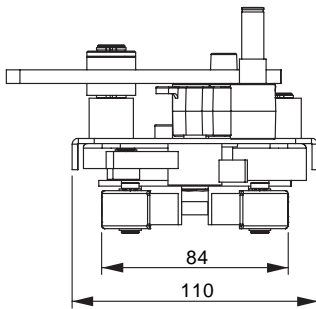
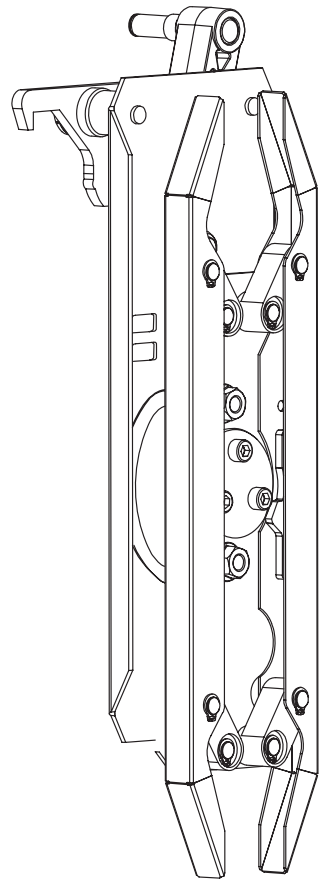
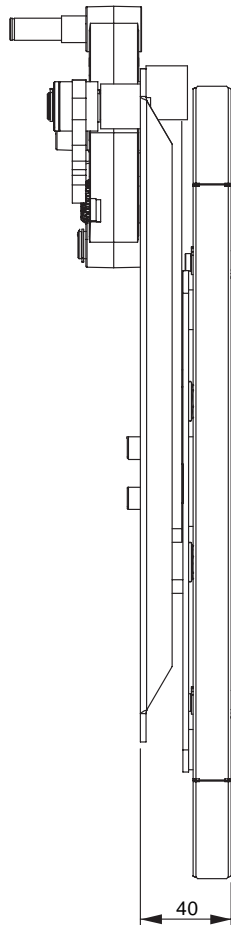
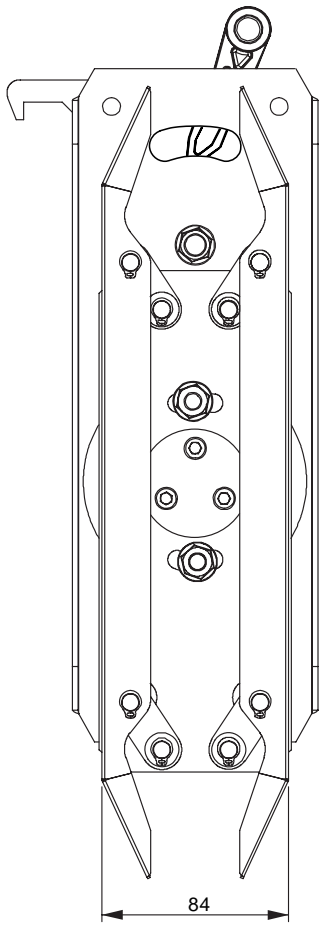

Para todo tipo de puertas de rellano automáticas
For all type of automatic landing doors

- ESCUADRA DE FIJACIÓN TIPO "A", (especial para puertas de rellano modelo DIN 18.091)
MOUNTING BRACKET MODEL "A", (special for automatic landing doors model DIN 18.091)

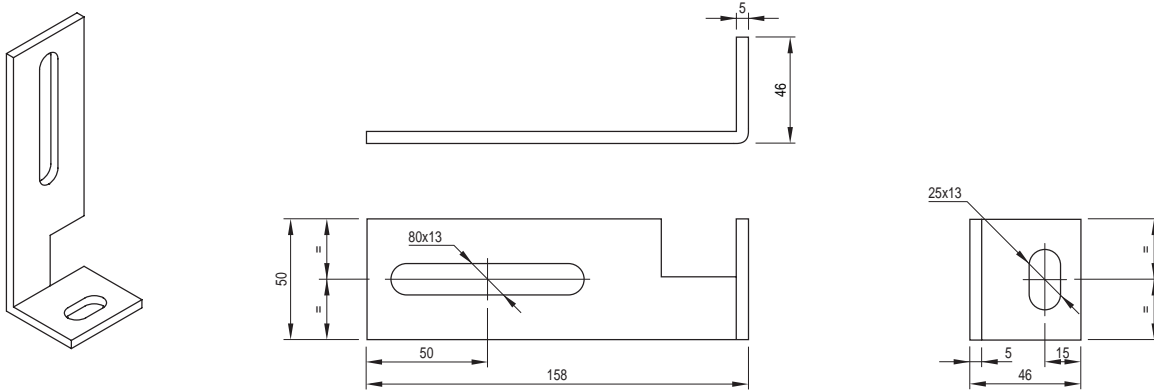

- ESCUADRA DE FIJACIÓN TIPO "D", (especial para puertas de rellano modelo DIN 18.091)
MOUNTING BRACKET MODEL "D", (special for automatic landing doors model DIN 18.091)

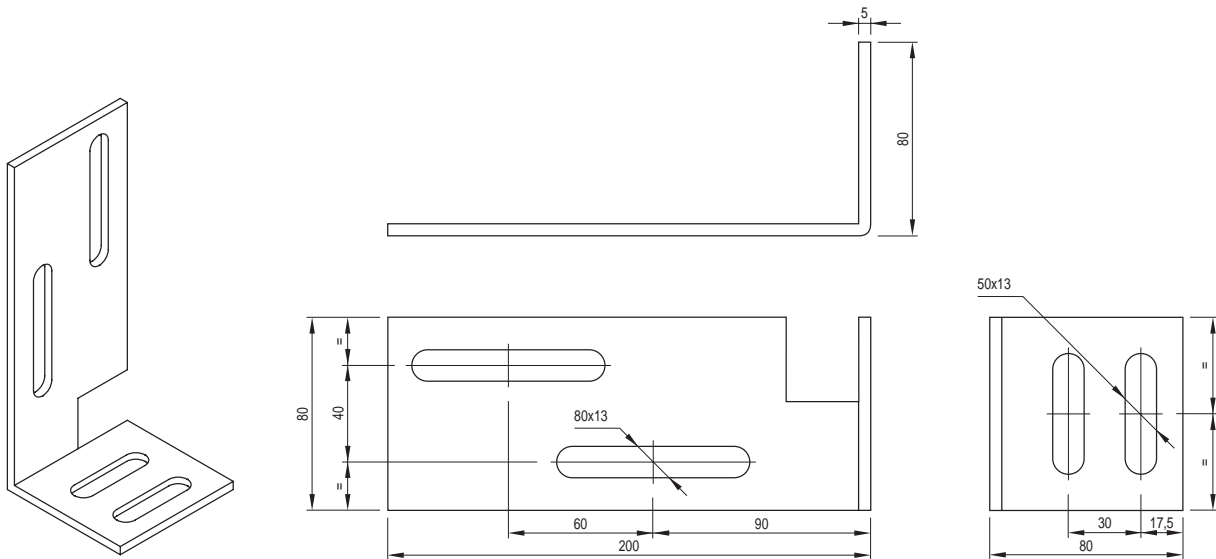

- ESCUADRA DE FIJACIÓN TIPO "E"
MOUNTING BRACKET MODEL "E"

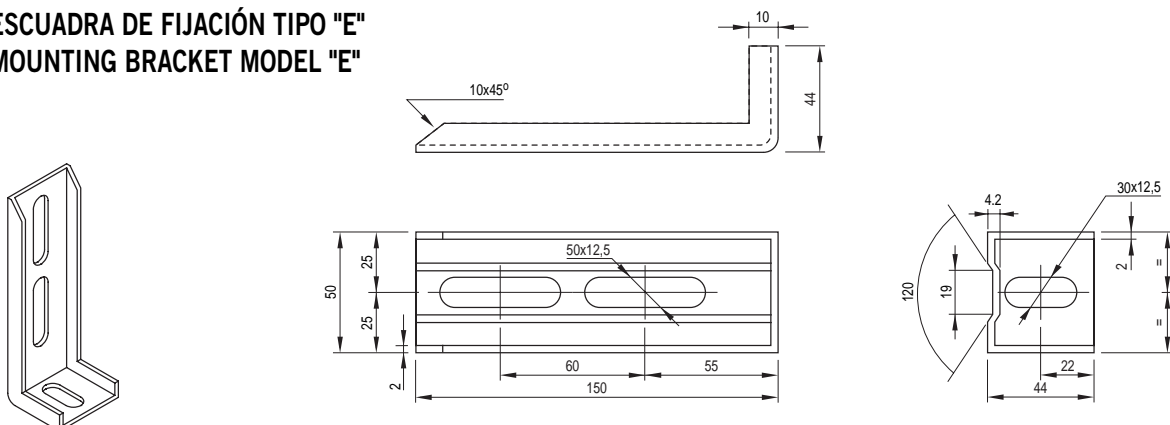

Para todo tipo de puertas de rellano automáticas
For all type of automatic landing doors

- ESCUADRA DE FIJACIÓN TIPO "F"
MOUNTING BRACKET MODEL "F"

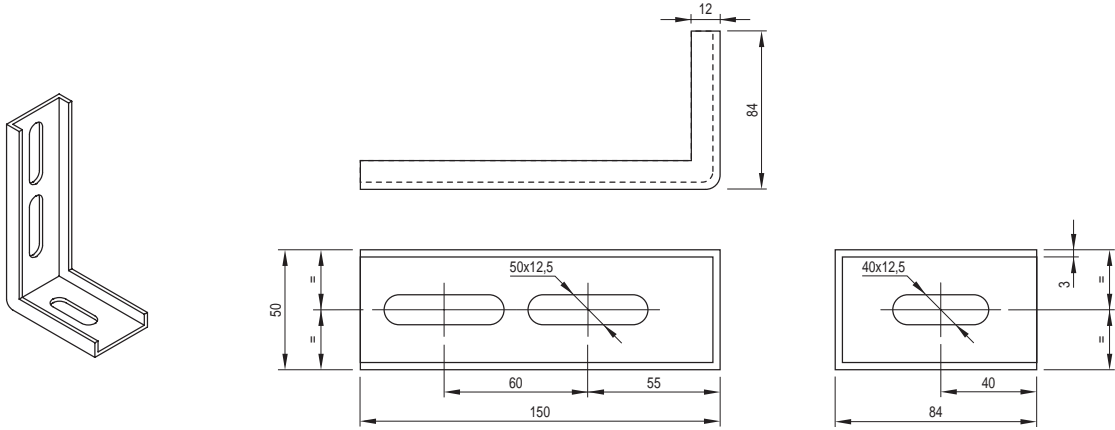

- ESCUADRA DE FIJACIÓN TIPO "G"
MOUNTING BRACKET MODEL "G"

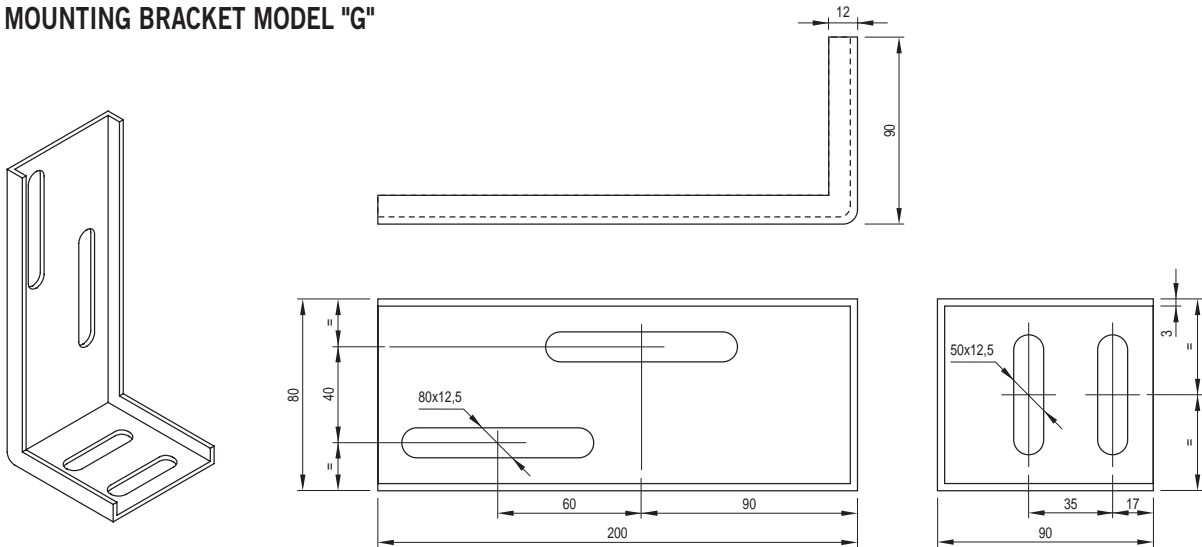

- ESCUADRA DE FIJACIÓN TIPO "H"
MOUNTING BRACKET MODEL "H"

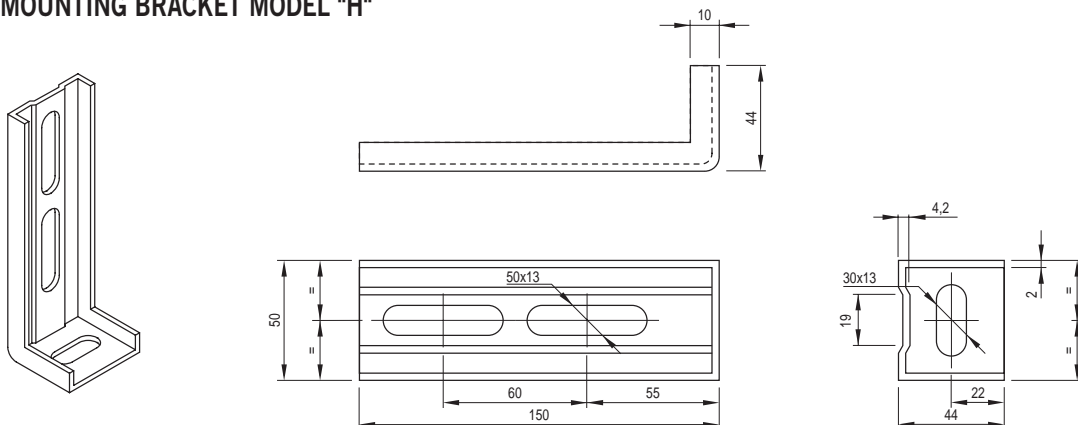

Para todo tipo de puertas de rellano automáticas
For all type of automatic landing doors

• ESCUADRA DE FIJACIÓN TIPO "V8"
MOUNTING BRACKET TYPE "V8"

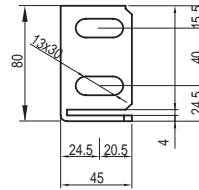
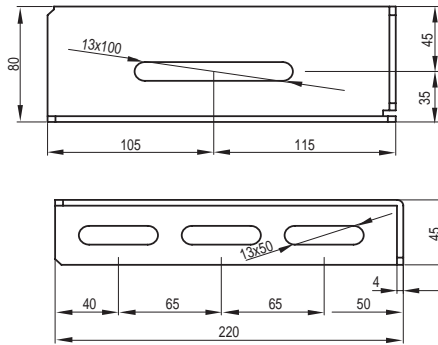
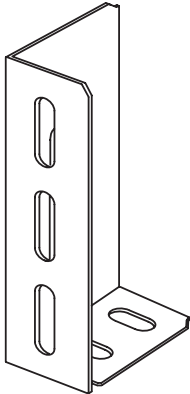

Colocación escuadra tipo "v8"
Ancho pisadera inferior a 80 mm.
Situation mounting bracket type "v8"
Width sill lower than 80 mm.

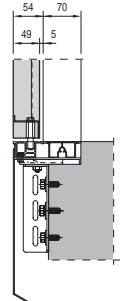

• ESCUADRA DE FIJACIÓN TIPO "V2"
MOUNTING BRACKET TYPE "V2"

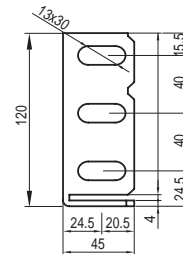
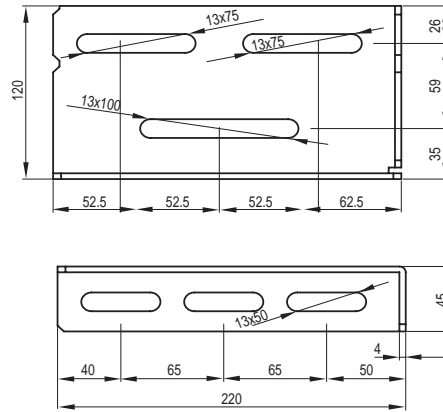
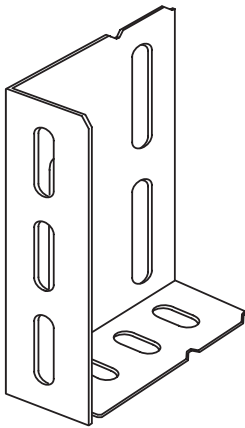

Colocación escuadra tipo "v2".
Ancho pisadera inferior a 120 mm.
Situation mounting bracket type "v2"
Width sill lower than 120 mm.

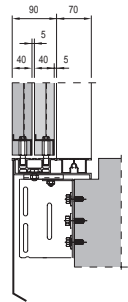

• ESCUADRA DE FIJACIÓN TIPO "V7"
MOUNTING BRACKET TYPE "V7"

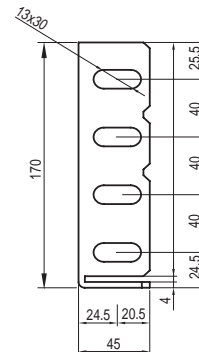
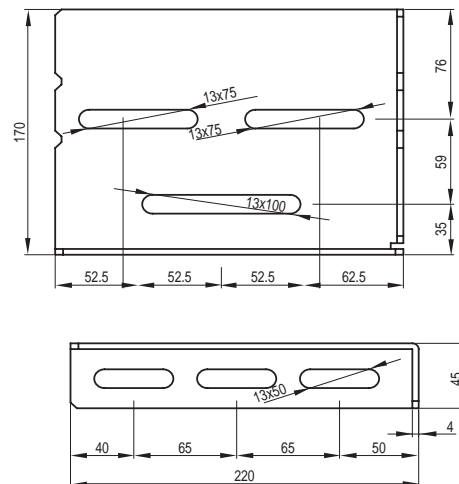
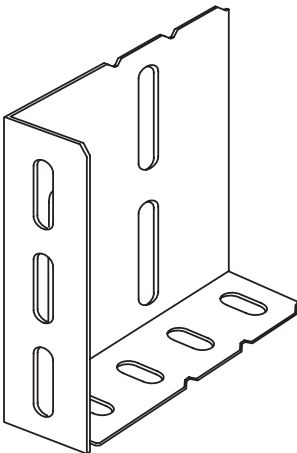

Colocación escuadra tipo "v7".
Ancho pisadera inferior a 170 mm.
Situation mounting bracket type "v7"
Width sill lower than 170 mm.

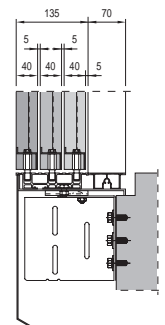

• CÓNLSOLA DE FIJACIÓN APOYOS PISADERA DE RELANO
LANDING TREAD SUPPORTS OF FIXATIONS CONSOLE

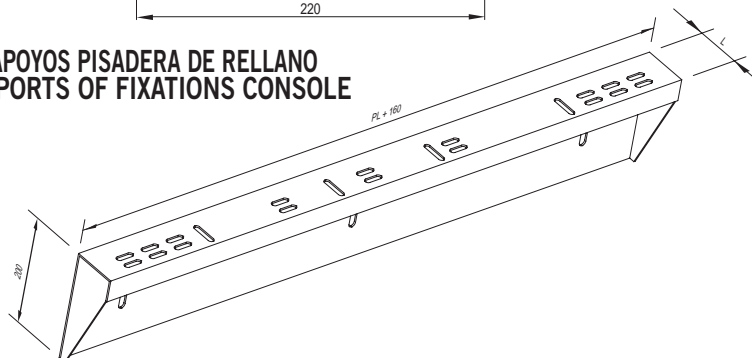

| L |
|-----|
| 50 |
| 80 |
| 130 |
| 190 |

PRC2H y PRT1H 2PCO & 1PSO

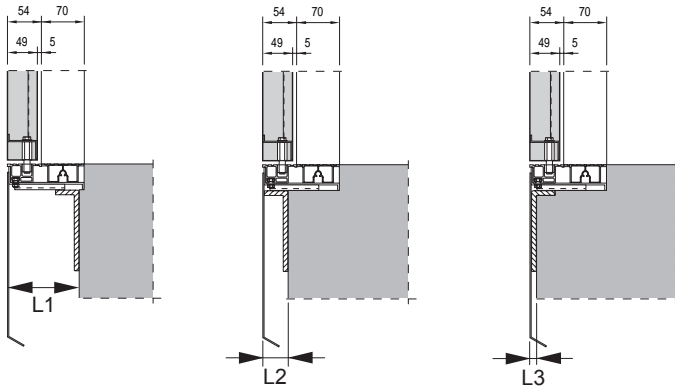

| Escuadra Bracket | Proyección al hueco / Projection to shaft | | |
|---------------------|---|-----|-----|
| | L1 | L2 | L3 |
| A | 95 | 46 | 15 |
| D | 120 | 80 | 15 |
| H | 95 | 44 | --- |
| G | 120 | 90 | --- |
| V8 | 130 | 80 | --- |
| V2 | 170 | 120 | --- |
| V7 | 220 | 170 | --- |

PRC4H y PRT2H 4PCO & 2PSO

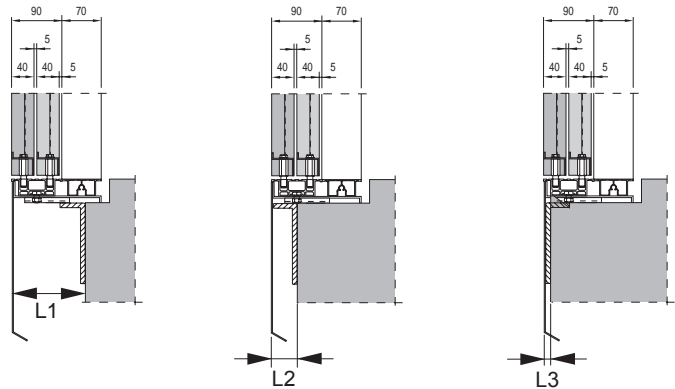

| Escuadra Bracket | Proyección al hueco / Projection to shaft | | |
|---------------------|---|-----|-----|
| | L1 | L2 | L3 |
| A | 95 | 46 | 15 |
| D | 130 | 89 | 15 |
| G | 140 | 90 | --- |
| V8 | 130 | 80 | --- |
| V2 | 170 | 120 | --- |
| V7 | 220 | 170 | --- |

PRC6H y PRT3H 6PCO & 3PSO

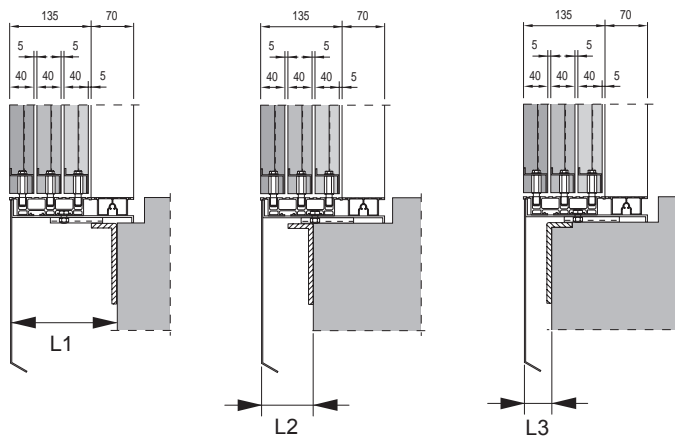

| Escuadra Bracket | Proyección al hueco / Projection to shaft | | |
|---------------------|---|-----|-----|
| | L1 | L2 | L3 |
| A | 95 | 64 | 55 |
| G | 140 | 115 | --- |
| V8 | 130 | 120 | --- |
| V2 | 170 | 120 | --- |
| V7 | 220 | 170 | --- |

PRC8H y PRT4H 8PCO & 4PSO

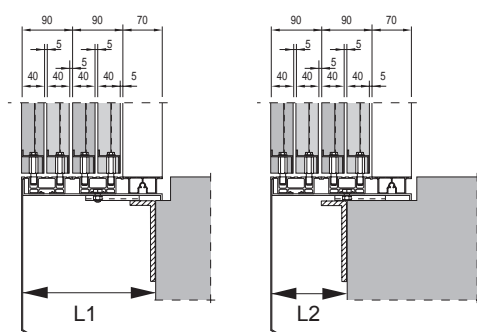

| Escuadra Bracket | Proyección al hueco / Projection to shaft | |
|---------------------|---|-----|
| | L1 | L2 |
| A | 95 | 64 |
| G | 140 | 115 |
| V8 | 130 | 120 |
| V2 | 170 | 120 |
| V7 | 220 | 170 |

RECOMENDACIÓN DE USO EN BASE A LA CAPACIDAD DE CARGA
RECOMENDATION USE ACCORDING LOADING WEIGHT

Los valores de carga expresados se refieren al peso que pueden soportar las pisaderas en sus puntos más débiles, (sin tener en cuenta los soportes de las mismas), las cargas recomendadas no ejercen deformación elástica alguna sobre las pisaderas. La carga total se dispone repartida en cuatro puntos.

The specified load values are about the weight that the sills can support, on their weakest points (without taking in consideration their supports). The recommended weight don't exercise any elastic deformation on the sills. The total loading is divided in four points.

• **PISADERA DE ALUMINIO STANDARD**
STANDARD ALUMINIUM SILL

Carga total:
Total weight: 1.200 Kgs.
Carga en punto de apoyo:
Load in support point: 300 Kgs.

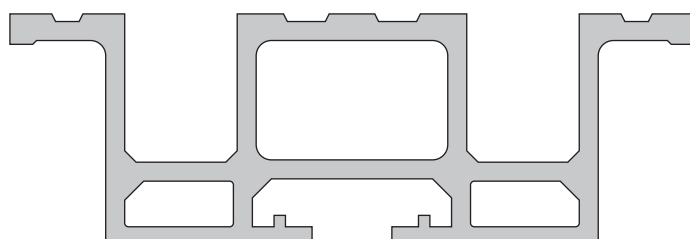

• **PISADERA DE CHAPA**
STEEL SILL

Carga total:
Total weight: 3.600 Kgs.
Carga en punto de apoyo:
Load in support point: 900 Kgs.

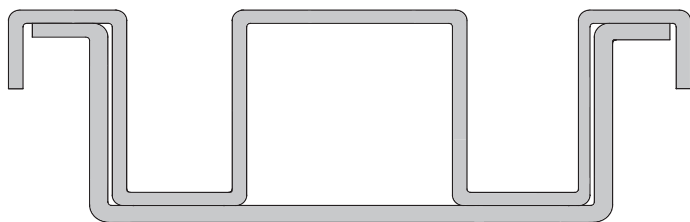

• **PISADERA DE ALUMINIO REFORZADA**
REINFORCED ALUMINIUM SILL

Carga total:
Total weight: 4.800 Kgs.
Carga en punto de apoyo:
Load in support point: 1.200 Kgs.

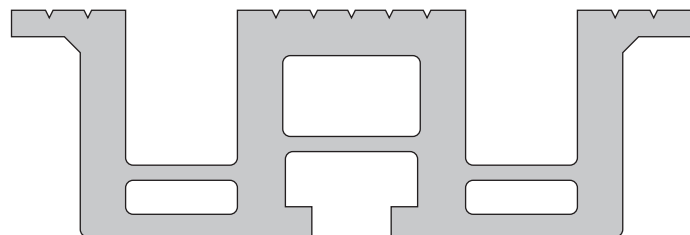

• **PISADERA MACIZA**
MASSIVE SILL

Carga total:
Total weight: >4.800 Kgs.
Carga en punto de apoyo:
Load in support point: >1.200 Kgs.

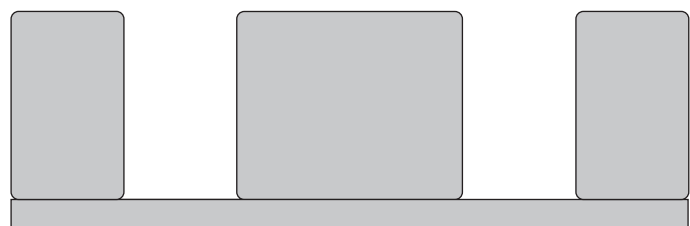

Los clientes de Fermator pueden seleccionar entre una amplia gama de puertas especiales que se fabrican para incluir los parámetros de diseño siguientes:

- Puertas anti-exposición.
- Puertas con protección IP-54.
- Operadores situados en la parte inferior de la cabina.
- Puertas para ascensores inclinados.
- Operadores especiales de pisadera calefactada y con guía oculta.
- Puertas especiales para alturas a partir de 3500mm. y PL a partir de 4000mm.

Fermator customers can select from amongst the wide range of special doors which are manufactured to include the following design parameters:

- Explosion proof doors.
- Water proof doors to IP-54.
- Operators placed at the inferior part of the cabin.
- Doors for inclined lifts.
- Special operators with headed sill and concealed guide.
- Special doors for clear highs from 3500mm. and CO from 4000mm.



Ferretor

AUTOMATIC DOORS FOR LIFTS

HOMOLOGACIONES DE FUEGO
FIRE HOMOLOGATIONS

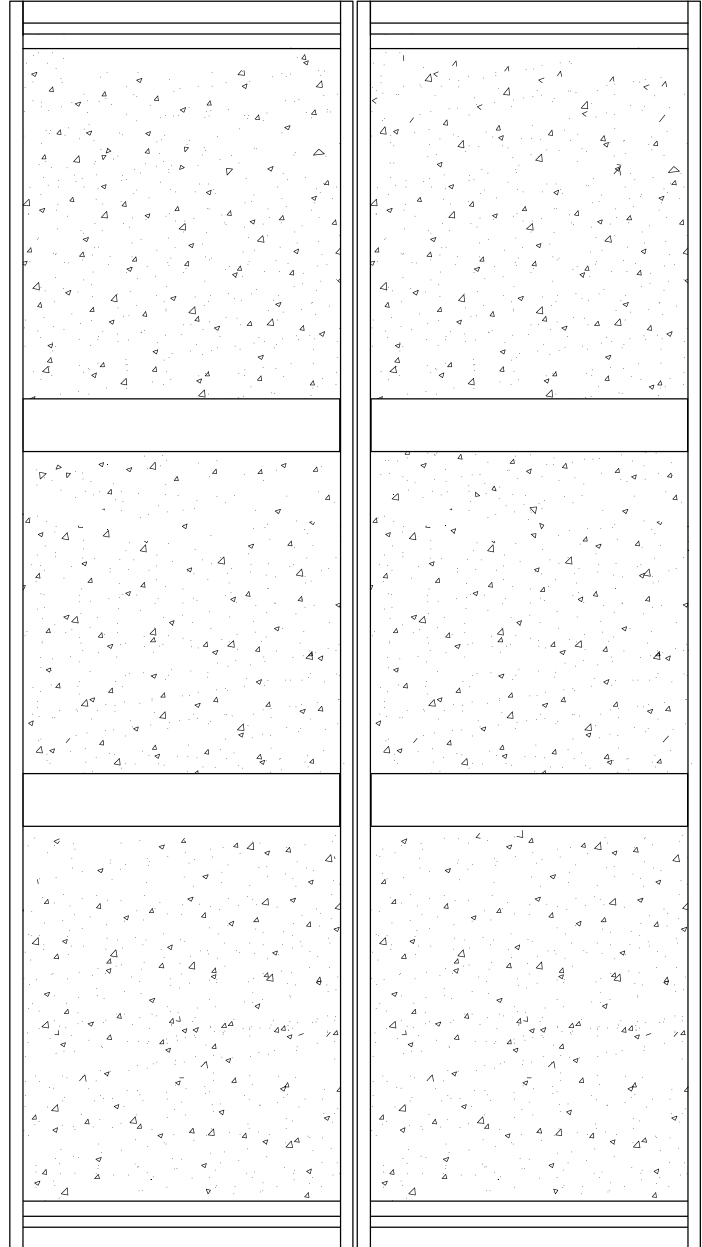

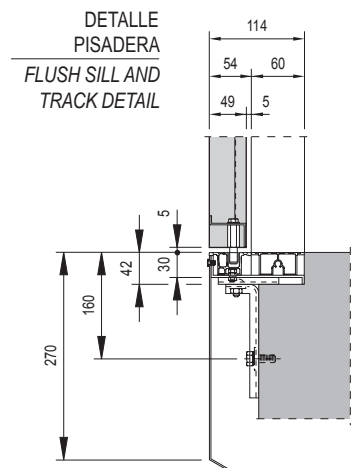
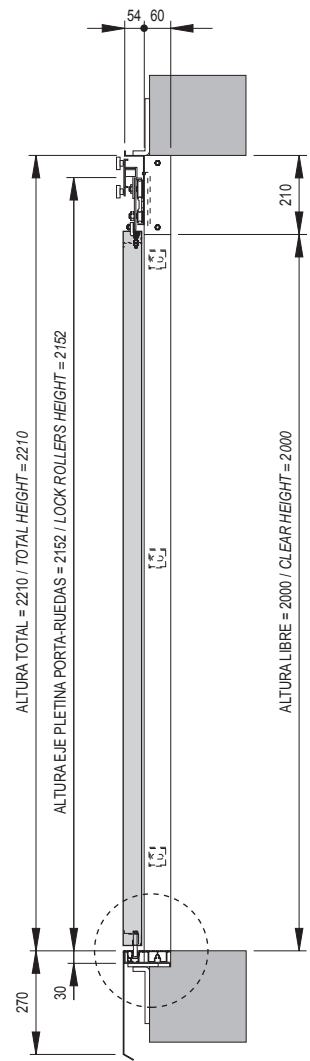
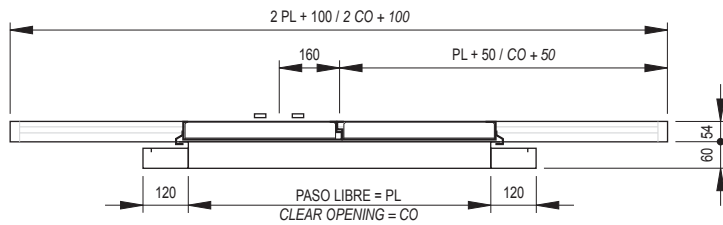
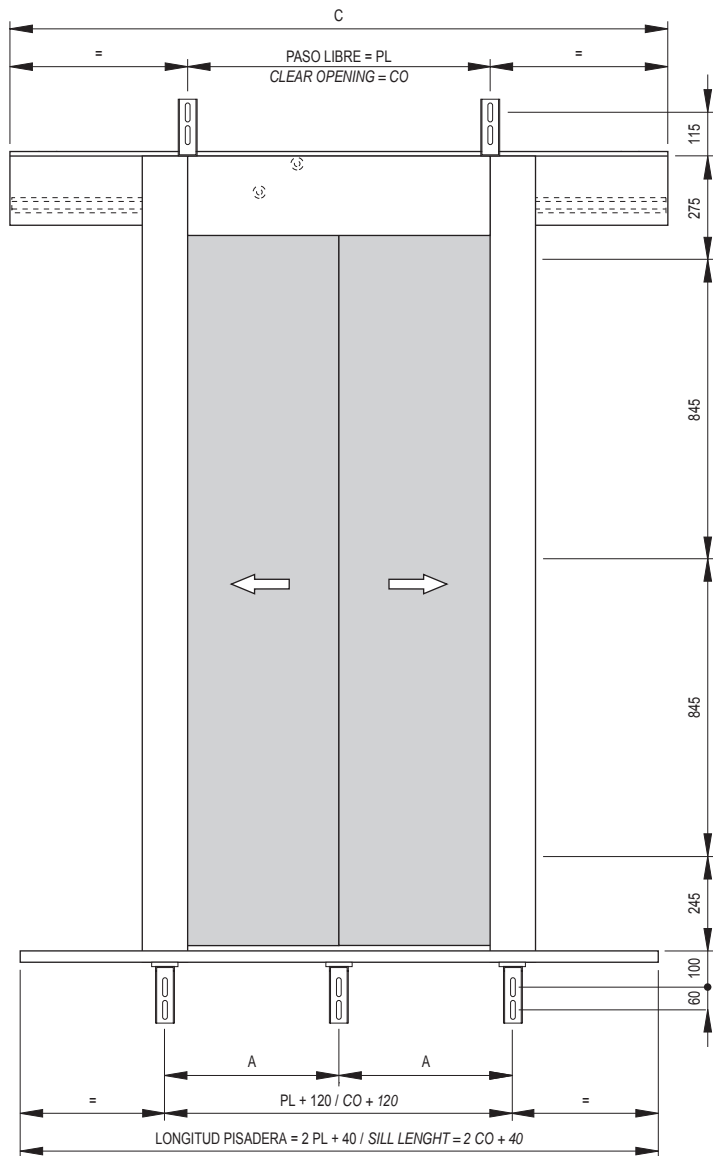

| PL / CO | 600 | 650 | 700 | 750 | 800 | 850 | 900 | 1000 | 1100 | 1200 | 1300 | 1400 | 1500 | 1600 | 1700 | 1800 | 1900 | 2000 |
|---------|------|------|------|------|------|------|------|------|------|------|------|------|------|------|------|------|------|------|
| C | 1300 | 1400 | 1500 | 1600 | 1700 | 1800 | 1900 | 2100 | 2300 | 2500 | 2700 | 2900 | 3100 | 3300 | 3500 | 3700 | 3900 | 4100 |
| A | 360 | 385 | 410 | 435 | 460 | 485 | 340 | 373 | 407 | 330 | 355 | 380 | 324 | 344 | 303 | 320 | 337 | 303 |
| S | 3 | 3 | 3 | 3 | 3 | 3 | 4 | 4 | 4 | 5 | 5 | 5 | 6 | 6 | 7 | 7 | 7 | 8 |
| T | 5 | 5 | 5 | 5 | 5 | 5 | 6 | 6 | 6 | 8 | 8 | 8 | 9 | 9 | 10 | 11 | 11 | 12 |

S: N° de soportes en apoyo pisadera.
S: Number of supports for sill support.

T: N° de soportes total.
T: Total number of supports.

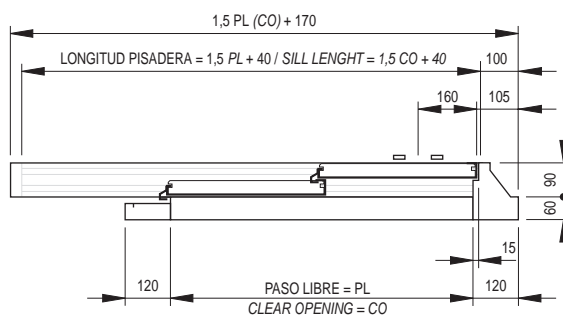
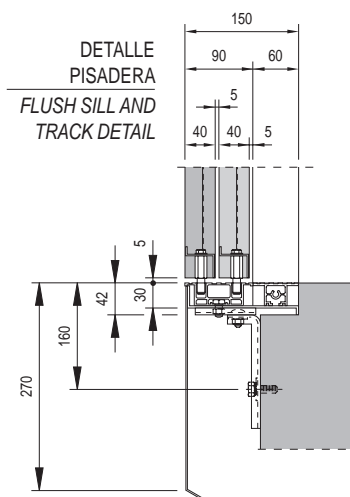
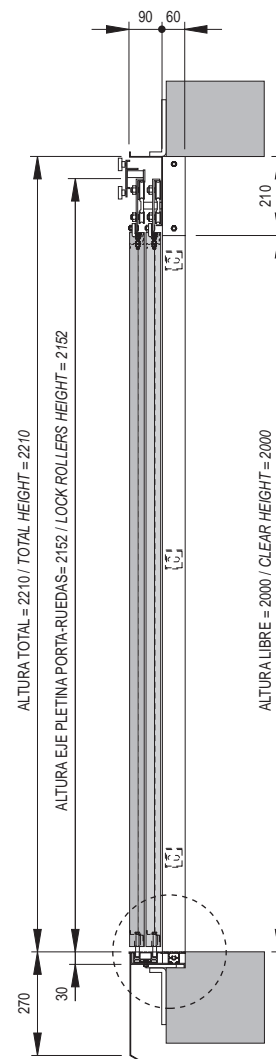
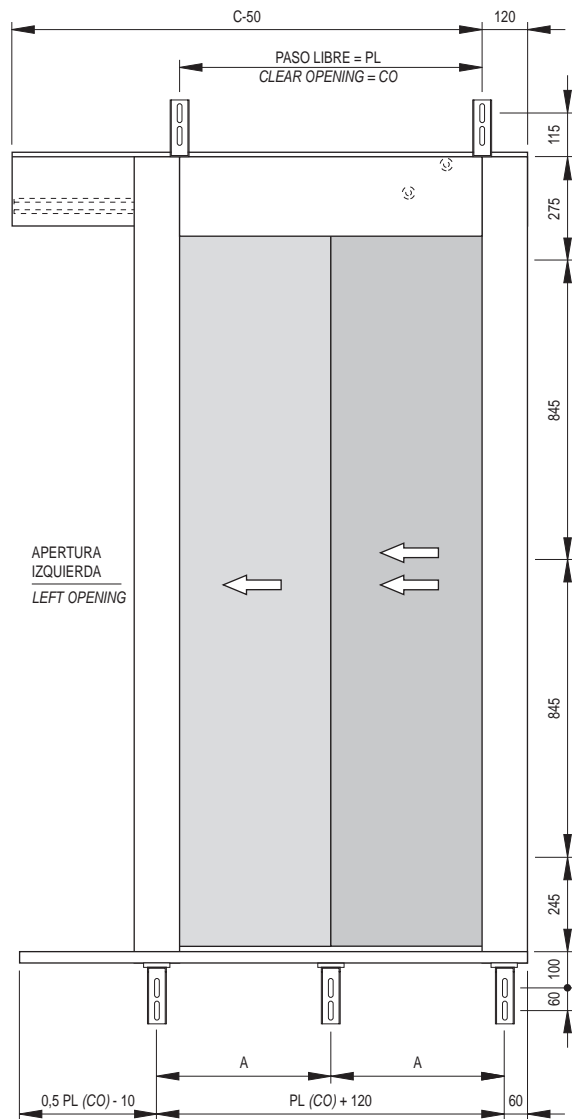

| PL / CO | 600 | 650 | 700 | 750 | 800 | 850 | 900 | 1000 | 1100 | 1200 | 1300 | 1400 |
|---------|------|------|------|------|------|------|------|------|------|------|------|------|
| C | 1000 | 1075 | 1150 | 1225 | 1300 | 1375 | 1450 | 1600 | 1750 | 1900 | 2050 | 2200 |
| A | 360 | 385 | 410 | 435 | 460 | 485 | 340 | 373 | 407 | 330 | 355 | 380 |
| S | 3 | 3 | 3 | 3 | 3 | 3 | 4 | 4 | 4 | 5 | 5 | 5 |
| T | 5 | 5 | 5 | 5 | 5 | 5 | 6 | 6 | 6 | 8 | 8 | 8 |

S: N°. de soportes en apoyo pisadera.
S: Number of supports for sill support.

T: N°. de soportes total.
T: Total number of supports.

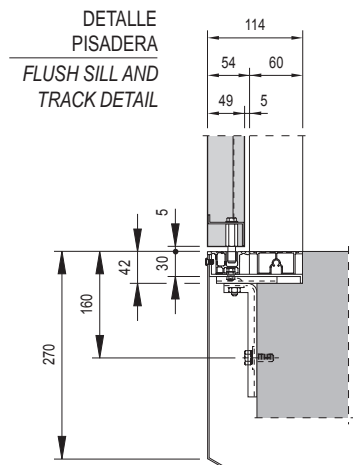
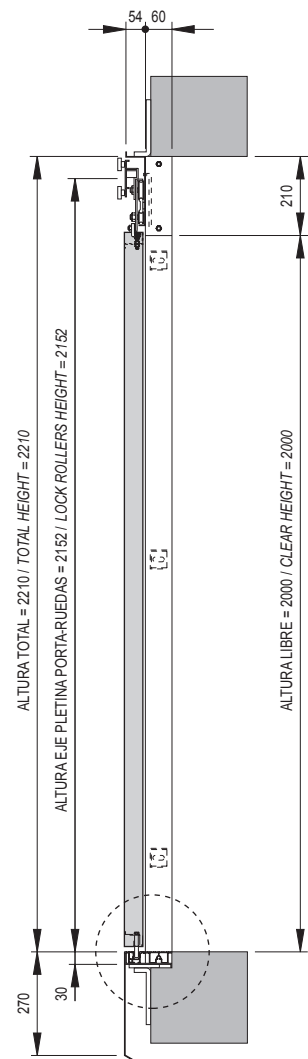
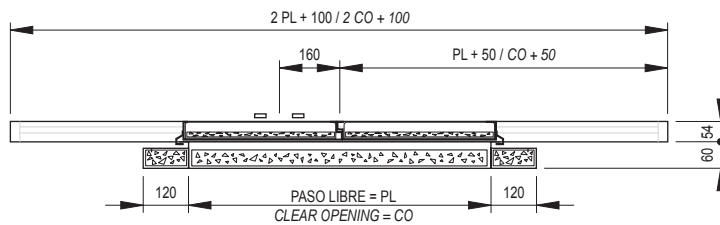
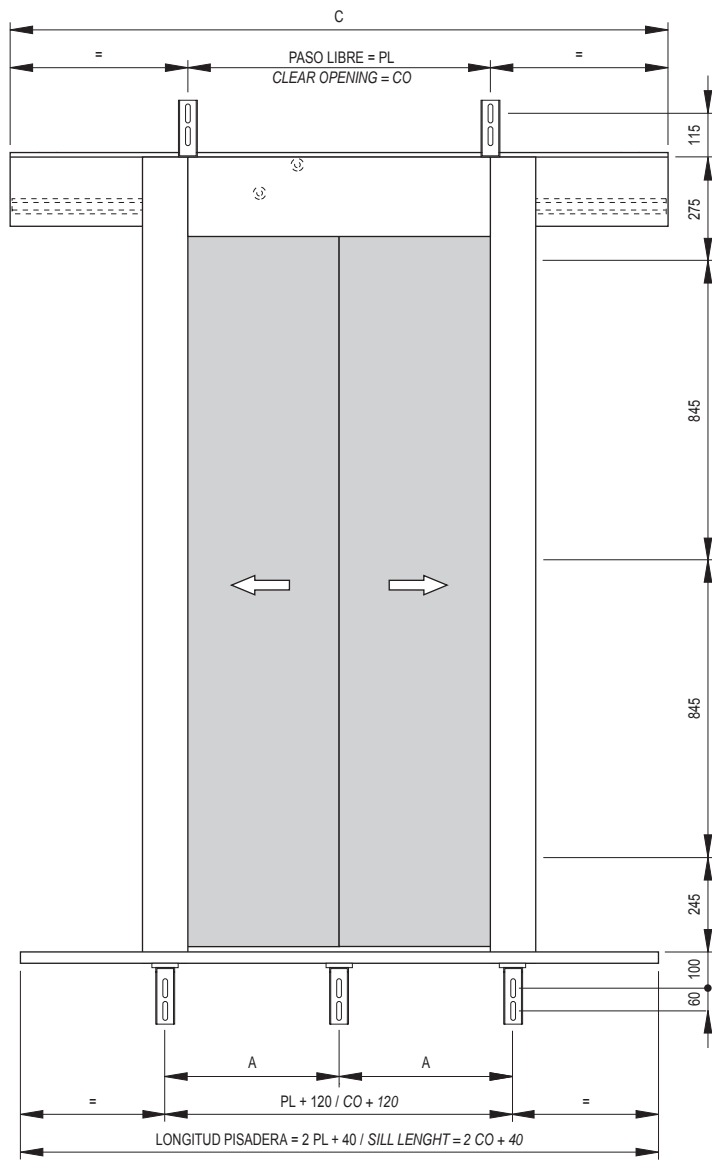

| PL / CO | 600 | 650 | 700 | 750 | 800 | 850 | 900 | 1000 | 1100 | 1200 | 1300 | 1400 | 1500 | 1600 | 1700 | 1800 | 1900 | 2000 |
|---------|------|------|------|------|------|------|------|------|------|------|------|------|------|------|------|------|------|------|
| C | 1300 | 1400 | 1500 | 1600 | 1700 | 1800 | 1900 | 2100 | 2300 | 2500 | 2700 | 2900 | 3100 | 3300 | 3500 | 3700 | 3900 | 4100 |
| A | 360 | 385 | 410 | 435 | 460 | 485 | 340 | 373 | 407 | 330 | 355 | 380 | 324 | 344 | 303 | 320 | 337 | 303 |
| S | 3 | 3 | 3 | 3 | 3 | 3 | 4 | 4 | 4 | 5 | 5 | 5 | 6 | 6 | 7 | 7 | 7 | 8 |
| T | 5 | 5 | 5 | 5 | 5 | 5 | 6 | 6 | 6 | 8 | 8 | 8 | 9 | 9 | 10 | 11 | 11 | 12 |

S: N°. de soportes en apoyo pisadera.
S: Number of supports for sill support.

T: N°. de soportes total.
T: Total number of supports.

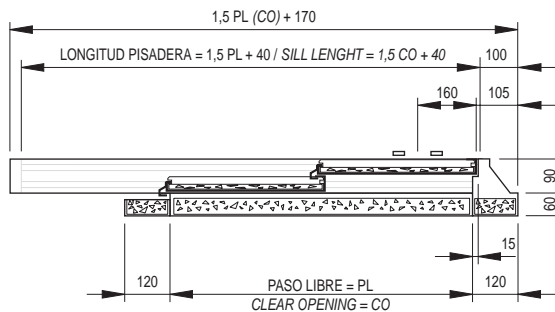
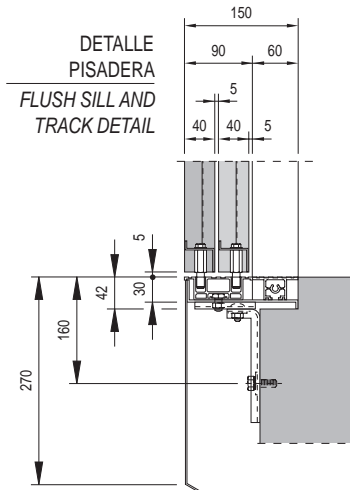
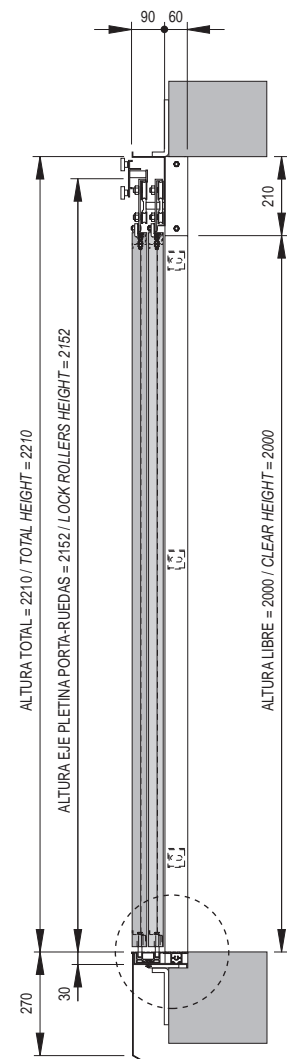
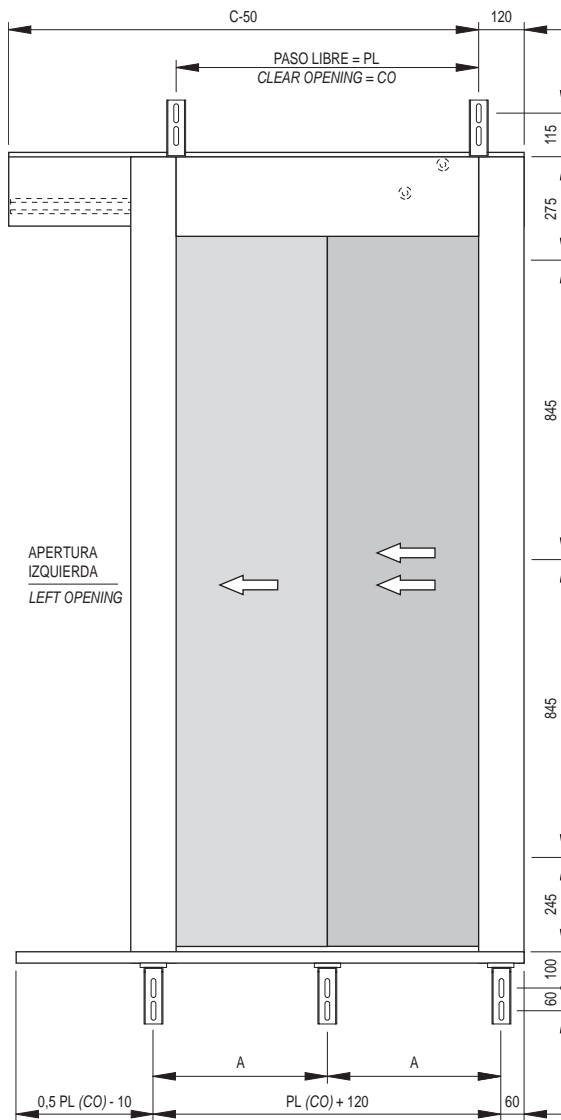

| PL / CO | 600 | 650 | 700 | 750 | 800 | 850 | 900 | 1000 | 1100 | 1200 | 1300 | 1400 |
|---------|------|------|------|------|------|------|------|------|------|------|------|------|
| C | 1000 | 1075 | 1150 | 1225 | 1300 | 1375 | 1450 | 1600 | 1750 | 1900 | 2050 | 2200 |
| A | 360 | 385 | 410 | 435 | 460 | 485 | 340 | 373 | 407 | 330 | 355 | 380 |
| S | 3 | 3 | 3 | 3 | 3 | 3 | 4 | 4 | 4 | 5 | 5 | 5 |
| T | 5 | 5 | 5 | 5 | 5 | 5 | 6 | 6 | 6 | 8 | 8 | 8 |

S: N° de soportes en apoyo pisadera.
S: Number of supports for sill support.

T: N° de soportes total.
T: Total number of supports.

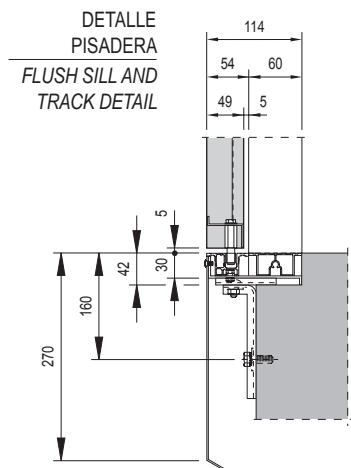
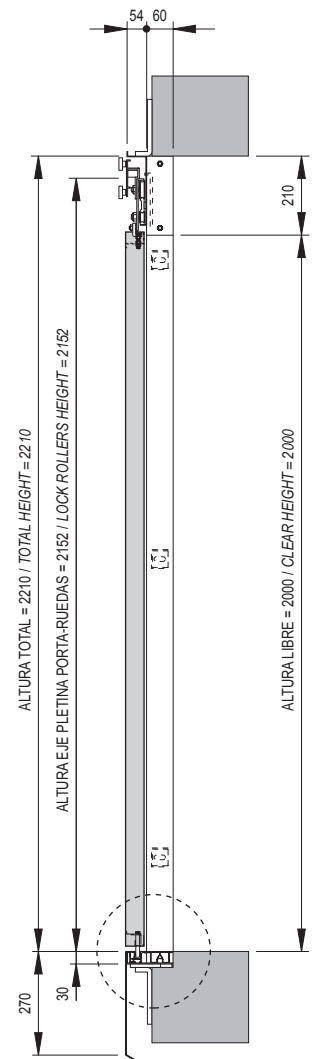
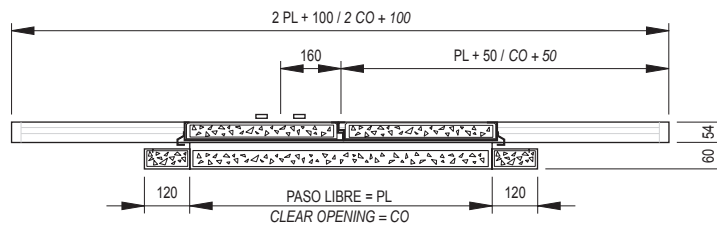
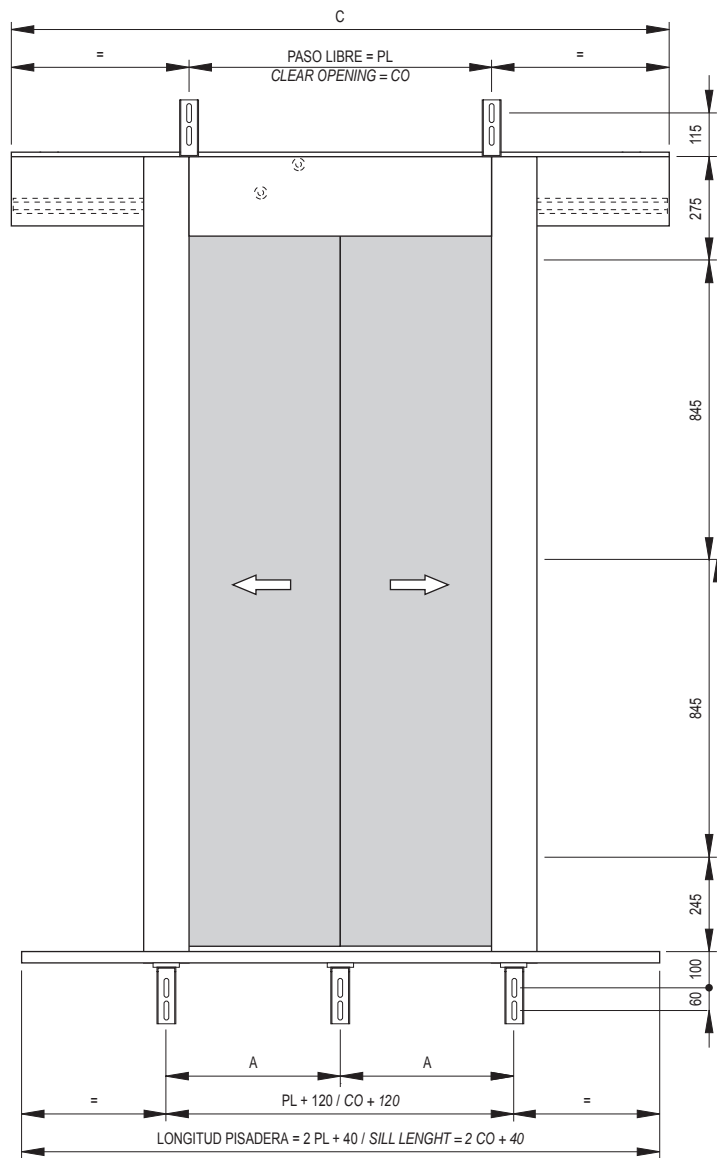

| PL / CO | 600 | 650 | 700 | 750 | 800 | 850 | 900 | 1000 | 1100 | 1200 | 1300 | 1400 | 1500 | 1600 | 1700 | 1800 | 1900 | 2000 |
|---------|------|------|------|------|------|------|------|------|------|------|------|------|------|------|------|------|------|------|
| C | 1300 | 1400 | 1500 | 1600 | 1700 | 1800 | 1900 | 2100 | 2300 | 2500 | 2700 | 2900 | 3100 | 3300 | 3500 | 3700 | 3900 | 4100 |
| A | 360 | 385 | 410 | 435 | 460 | 485 | 340 | 373 | 407 | 330 | 355 | 380 | 324 | 344 | 303 | 320 | 337 | 303 |
| S | 3 | 3 | 3 | 3 | 3 | 3 | 4 | 4 | 4 | 5 | 5 | 5 | 6 | 6 | 7 | 7 | 7 | 8 |
| T | 5 | 5 | 5 | 5 | 5 | 5 | 6 | 6 | 6 | 8 | 8 | 8 | 9 | 9 | 10 | 11 | 11 | 12 |

S: N°. de soportes en apoyo pisadera.
S: Number of supports for sill support.

T: N°. de soportes total.
T: Total number of supports.

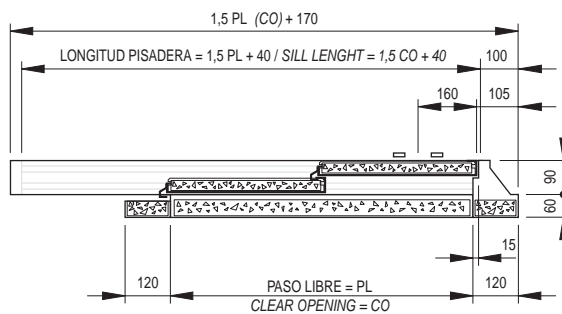
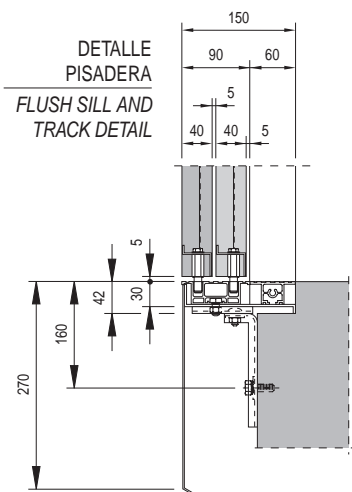
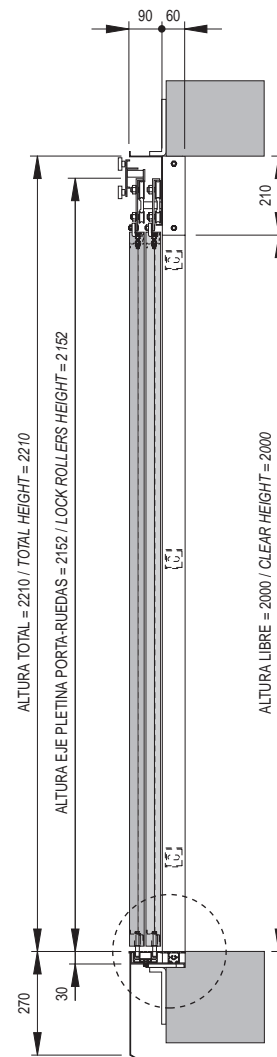
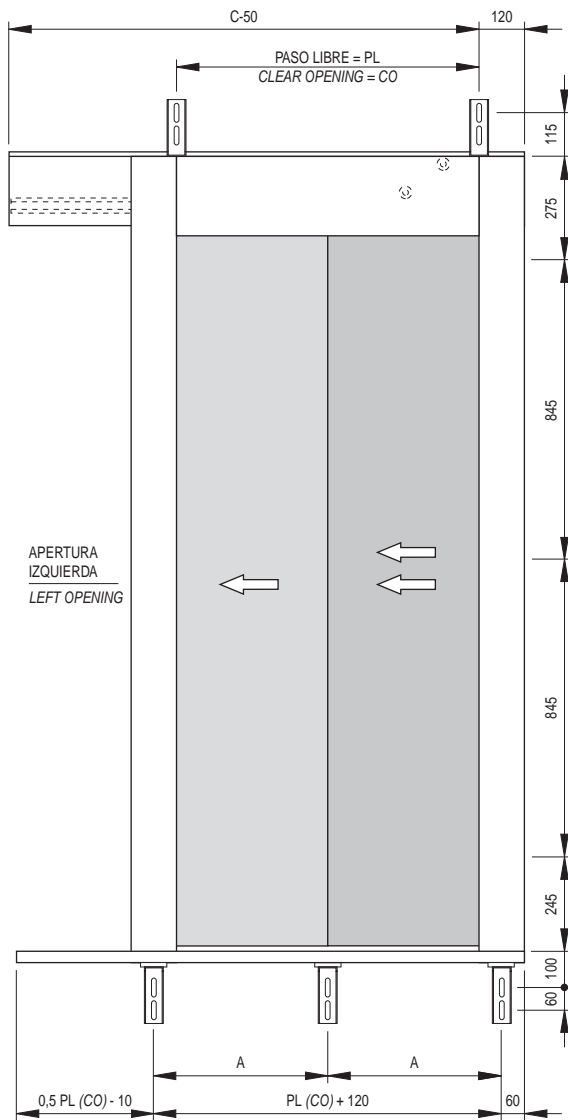

| PL / CO | 600 | 650 | 700 | 750 | 800 | 850 | 900 | 1000 | 1100 | 1200 | 1300 | 1400 |
|---------|------|------|------|------|------|------|------|------|------|------|------|------|
| C | 1000 | 1075 | 1150 | 1225 | 1300 | 1375 | 1450 | 1600 | 1750 | 1900 | 2050 | 2200 |
| A | 360 | 385 | 410 | 435 | 460 | 485 | 340 | 373 | 407 | 330 | 355 | 380 |
| S | 3 | 3 | 3 | 3 | 3 | 3 | 4 | 4 | 4 | 5 | 5 | 5 |
| T | 5 | 5 | 5 | 5 | 5 | 5 | 6 | 6 | 6 | 8 | 8 | 8 |

S: N° de soportes en apoyo pisadera.
S: Number of supports for sill support.

T: N° de soportes total.
T: Total number of supports.

PUERTAS PARALLAMAS (INTEGRIDAD) / FIRE RESISTANT DOOR (INTEGRITY)

EN 81-58

- PRC2/4/6/8 Puerta rellano central 2/4/6/8 hojas E 120
2/4/6/8 Panel centre opening landing door E 120 154727
- PRT1/2/3/4 Puerta rellano telescópica 1/2/3/4 hojas E 120
1/2/3/4 Panel side opening landing door: E 120 154727

ALEMANIA / GERMANY (DIN 18091)

- PRC2/4/6 Puerta rellano central 2/4/6 hojas F 90
2 Panel centre opening landing door F 90
- PRT1/2/3 Puerta rellano telescópica 1/2/3 hoja F 90
1/2/3 Panel side opening landing door F 90

BELGICA / BELGIUM

- PRC2/4/6 Puerta rellano central 2/4/6 hojas PF 60
2/4/6 Panel centre opening landing door PF 60 2003-L-062
- PRT2 Puerta rellano telescópica 2 hojas PF 90
2 Panel side opening landing door PF 90 2003-L-047

ESPAÑA / SPAIN

- PRC2 Puerta rellano central 2 hojas PF 60
2 Panel centre opening landing door PF 60 96010714
- PRC4 Puerta rellano central 4 hojas PF 120
4 Panel centre opening landing door PF 120 96.000.459
- PRC6 Puerta rellano central 6 hojas PF 120
6 Panel centre opening landing door PF 120 21.000.655
- PRC8 Puerta rellano central 8 hojas: PF 120
8 Panel centre opening landing door PF 120 152048
- PRT1 Puerta rellano telescópica 1 hoja: PF 120
1 Panel side opening landing door PF 120 95.007.708
- PRT2 Puerta rellano telescópica 2 hojas: PF 120
2 Panel side opening landing door PF 120 96.010.713
- PRT3 Puerta rellano telescópica 3 hojas: PF 120
3 Panel side opening landing door PF 120 96.007.477
- PRT4 Puerta rellano telescópica 4 hojas: PF 120
4 Panel side opening landing door PF 120 21.021.975

FRANCIA / FRANCE

- PRC2 Puerta rellano central 2 hojas: PF 120
2 Panel centre opening landing door PF 120 95-V-135
- PRC4 Puerta rellano central 4 hojas: PF 90
4 Panel centre opening landing door PF 90 04-G-050
- PRC6 Puerta rellano central 6 hojas: PF 60
6 Panel centre opening landing door PF 60 95-G-213
- PRT2 Puerta rellano telescópica 2 hojas: PF 90
2 Panel side opening landing door PF 90 01-V-138
- PRT3 Puerta rellano telescópica 3 hojas: PF 30
3 Panel side opening landing door PF 30 01-A-267

GRAN BRETAÑA / GREAT BRITAIN

- PRC2 Puerta rellano central 2 hojas: PF 120
2 Panel centre opening landing door PF 120 11.751
- PRC2 Puerta rellano central 2 hojas Inox PF 180
2 Panel centre opening landing door PF 180 113248
- PRC4 Puerta rellano central 4 hojas PF 120
4 Panel centre opening landing door PF 120 133233
- PRC6 Puerta rellano central 6 hojas PF 120
6 Panel centre opening landing door PF 120 136481
- PRC8 Puerta rellano central 8 hojas PF 120
8 Panel centre opening landing door PF 120 143546
- PRT1 Puerta rellano telescópica 1 hoja PF 120
1 Panel side opening landing door PF 120 136471
- PRT2 Puerta rellano telescópica 2 hojas PF 120
2 Panel side opening landing door PF 120 175350A
- PRT3 Puerta rellano telescópica 3 hojas PF 120
3 Panel side opening landing door PF 120 11752

RUSIA / RUSSIA

- PRC2 Puerta rellano central 2 hojas E 30
2 Panel centre opening landing door E30 73 B 00471
- PRC4 Puerta rellano central 4 hojas E 30
4 Panel centre opening landing door E30 73 B 00468
- PRT2 Puerta rellano telescópica 2 hojas E 30
2 Panel side opening landing door E30 73 B 00472

SINGAPUR

- PRC2 Puerta rellano central 2 hojas PF 60
2 Panel centre opening landing door PF 60 G41947/CLT
- PRT2 Puerta rellano telescópica 2 hojas PF 60
2 Panel side opening landing door PF 60 G45721/KKC

USA / CANADA

- PRC2/4/6 2/4/6 Hoja de rellano central PF 90
2/4/6 Panel centre opening landing door PF 90 51-0486.01
- PRT1/2/3 1/2/3 Hoja de rellano telescópica PF 90
1/2/3 Panel side opening landing door PF 90 651-0486.01

HONG KONG

- PRC2 Puerta rellano central 2 hojas Inox PF 180
2 Panel centre opening landing door PF 180 113248

* Opción con marco reducido.
Frameless option.

PUERTAS CON AISLAMIENTO TÉRMICO / DOORS WITH THERMIC INSULATION*

EN 81-58

| | | |
|--------------|--|------------|
| • PRC2/4/6/8 | Puerta rellano central 2/4/6/8 hojas EW 60 2/4/6/8 Panel centre parting landing door EW 60 | 155663 |
| • PRT1/2/3/4 | Puerta rellano telescópica 1/2/3/4 hoja EW 60 1/2/3/4 Panel side opening landing door EW 60 | 155663 |
| • PRC2/4/6/8 | Puerta rellano central 2/4/6/8 hojas EI 60 2/4/6/8 Panel centre parting landing door EI 60 | 177206 |
| • PRT1/2/3/4 | Puerta rellano telescópica 1/2/3/4 hoja EI 60 1/2/3/4 Panel side opening landing door EI 60 | 177206 |
| • PRC2/4/6/8 | Puerta rellano central 2/4/6/8 hojas EI 120 2/4/6/8 Panel centre parting landing door EI 120 | PR-06-0023 |
| • PRT1/2/3/4 | Puerta rellano telescópica 1/2/3/4 hoja EI 120 1/2/3/4 Panel side opening landing door EI 120 | PR-06-0023 |

ESPAÑA

| | | |
|--------|--|------------|
| • PRC2 | Puerta rellano central 2 hojas: RF 60 2 Panel centre parting landing door RF 60 | 97.002.388 |
| • PRT2 | Puerta rellano telescópica 2 hojas: RF 60 2 Panel side opening landing door RF 60 | 22.032.04 |

* Opción con marco reducido.
Frameless option.

GRAN BRETAÑA

| | | |
|---------------|---|------------------|
| • PRC2 | Puerta rellano central 2 hojas RF 60 2 Panel centre parting landing door RF 60 | 137699 |
| • PRT2 | Puerta rellano telescópica 2 hojas RF 60 2 Panel side opening landing door RF 60 | 137082 |
| ITALIA | | |
| • PRC2 | Puerta rellano central 2 hojas REI 90 2 Panel centre parting landing door REI 90 | CSI 1164 |
| • PRC4 | Puerta rellano central 4 hojas REI 90 4 Panel centre parting landing door REI 90 | CSI 1164 |
| • PRC6 | Puerta rellano central 6 hojas REI 90 6 Panel centre parting landing door REI 90 | CSI 1164 |
| • PRT2 | Puerta rellano telescópica 2 hojas REI 120 2 Panel side opening landing door REI 120 | EUE205REI120P001 |

RUSIA

| | | |
|--------|---|------------|
| • PRC2 | Puerta rellano central 2 hojas EI 60 2 Panel centre parting landing door EI 60 | 73 B 00470 |
| • PRC4 | Puerta rellano central 4 hojas EI 60 4 Panel centre parting landing door EI 60 | 73 B 00469 |
| • PRT2 | Puerta rellano telescópica 2 hojas EI 60 2 Panel side opening landing door EI 60 | 73 B 00473 |

PUERTAS CRISTAL MODELO GRAN MIRILLA / GLASS DOORS BIG VISION MODEL

EN 81-58

| | | |
|--------|---|-------------------|
| • PRC2 | Puerta rellano central 2 hojas "Gran Mirilla" E 60 2 Panels centre parting landing door "Big Vision" E 60 | FR-CR-036-07-NURE |
| • PRC4 | Puerta rellano central 4 hojas "Gran Mirilla" E 60 4 Panels centre parting landing door "Big Vision" E 60 | FR-CR-036-07-NURE |
| • PRT2 | Puerta rellano telescópica 2 hojas "Gran Mirilla" E 60 2 Panel side opening landing door "Big Vision" E 60 | FR-CR-036-07-NURE |
| • PRC2 | Puerta rellano central 2 hojas "Gran Mirilla" EI 30 2 Panels centre parting landing door "Big Vision" EI 30 | 155660 |
| • PRC4 | Puerta rellano central 4 hojas "Gran Mirilla" EI 30 4 Panels centre parting landing door "Big Vision" EI 30 | 155660 |
| • PRT2 | Puerta rellano telescópica 2 hojas "Gran Mirilla" EI 30 2 Panel side opening landing door "Big Vision" EI 30 | 155660 |

ESPAÑA

| | | |
|--------|--|------------|
| • PRC2 | Puerta rellano central 2 hojas "Gran Mirilla" PF 60 2 Panels centre parting landing door "Big Vision" PF 60 | 4001076 |
| • PRT2 | Puerta rellano telescópica 2 hojas "Gran Mirilla" E 60 2 Panel side opening landing door "Big Vision" E 60 | 21.015.512 |

FRANCIA

| | | |
|--------|--|------------|
| • PRC2 | Puerta rellano central 2 hojas "Gran Mirilla" PF 60 2 Panels centre parting landing door "Big Vision" PF 60 | 04-V-297 |
| • PRT2 | Puerta rellano telescópica 2 hojas "Gran Mirilla" E 60 2 Panel side opening landing door "Big Vision" E 60 | 21.015.512 |

GRAN BRETAÑA

| | | |
|--------|--|--------|
| • PRC2 | Puerta rellano central 2 hojas "Gran Mirilla" PF 60 2 Panels centre parting landing door "Big Vision" PF 60 | 142007 |
|--------|--|--------|

PUERTAS SEMIAUTOMÁTICAS / HINGED DOORS

EN 81-58

- Puerta rellano semiautomática "Global" sin mirilla.
Hinged semi-automatic "Global" door without vision panel. 175599
- Puerta rellano semiautomática "Global" con mirilla.
Hinged semi-automatic "Global" door with vision panel. 175599
- Puerta rellano semiautomática "Fermator" sin mirilla.
Hinged semi-automatic "Fermator" door without vision panel. 175599
- Puerta rellano semiautomática "Fermator" con mirilla.
Hinged semi-automatic "Fermator" door with vision panel. 175599

BELGICA

- Puerta rellano semiautomática "Global" con mirilla PF 30
Hinged semi-automatic "Global" door with vision panel PF 30 4/EF/57.299/695A

USA / CANADA

- Puerta rellano semiautomática "Fermator" con mirilla PF 90
Hinged semi-automatic "Fermator" door with vision panel PF 90 651-0486.02

ESPAÑA

- Puerta rellano semiautomática "Global" sin mirilla PF 30
Hinged semi-automatic "Global" door without vision panel PF 30 20.016.336
- Puerta rellano semiautomática "Global" con mirilla: PF 30
Hinged semi-automatic "Global" door with vision panel PF 30 20.016.336
- Puerta rellano semiautomática "Fermator" sin mirilla: PF 120
Hinged semi-automatic "Fermator" door without vision panel PF 120 4023118
- Puerta rellano semiautomática "Fermator" con mirilla: PF 120
Hinged semi-automatic "Fermator" door with vision panel PF 120 4023118

FRANCIA

- Puerta rellano semiautomática "Fermator" sin mirilla: PF 30
Hinged semi-automatic "Fermator" door without vision panel PF 30 93.36117
- Puerta rellano semiautomática "Fermator" con mirilla PF 30
Hinged semi-automatic "Fermator" door with vision panel PF 30 93.36117

| PL/CO | 1000 | 900 | 800 | 700 | 600 | | 2000 | 2100 | 2200 | 2300 | HL/CH |
|--|------|-----|-----|-----|-----|----------|--------|------|------|------|--|
| PF-120 Con Mirilla PF-120 With Vision Panel | | | | | | Fermator | | | | | PF-120 Con Mirilla PF-120 With Vision Panel |
| PF-30 FR Con Mirilla PF-30 FR With Vision Panel | | | | | | | | | | | PF-30 FR Con Mirilla PF-30 FR With Vision Panel |
| PF-30 BEL Con Mirilla PF-30 BEL With Vision Panel | | | | | | | | | | | PF-30 BEL Con Mirilla PF-30 BEL With Vision Panel |
| E120 EN 81-58 Con mirilla E120 EN 81-58 with vision panel | | | | | | | | | | | E120 EN 81-58 Con mirilla E120 EN 81-58 with vision panel |
| PF-60 Sin Mirilla PF-60 Without Vision Panel | | | | | | | Global | | | | |
| PF-30 Con Mirilla PF-30 With Vision Panel | | | | | | | | | | | PF-30 Con Mirilla PF-30 With Vision Panel |
| E120 EN 81-58 Con mirilla E120 EN 81-58 with vision panel | | | | | | | | | | | E120 EN 81-58 Con mirilla E120 EN 81-58 with vision panel |
| | | | | | | | | | | | |
| PL/CO | 1000 | 900 | 800 | 700 | 600 | | 2000 | 2100 | 2200 | 2300 | HL/CH |

■ Dimensión disponible.
■ Dimension available.

PUERTAS LB / LB DOORS

EN 81-58

- Puerta de rellano LB (Linear Bus).
Linear Bus folding lift landing door, type LB FR-233-07

| PL/CO | 1000 | 900 | 800 | 700 | 600 | | 2000 | 2100 | 2200 | 2300 | HL/CH |
|---------------|------|-----|-----|-----|-----|---------------|------|------|------|------|--------------|
| E30 EN 81-58 | | | | | | Linear Bus | | | | | E30 EN 81-58 |
| EW30 EN 81-58 | | | | | | | | | | | |
| PL/CO | 1000 | 900 | 800 | 700 | 600 | | 2000 | 2100 | 2200 | 2300 | HL/CH |

■ Dimensión disponible.
■ Dimension available.

ENCLAVAMIENTO DE LA PUERTA DE RELANO / LANDING DOOR LOCK



LNE Paris

- PRC2/4/6 Enclavamiento puertas de rellano centrales 2/4/6 paneles, modelo 40/10
2/4/6 panels centre opening landing doors lock, model 40/10 0071/0199/02
- PRT1/2/3 Enclavamiento Puertas de rellano telescópicas 1/2/3 paneles, modelo 40/10
2/4/6 panels centre opening landing doors lock, model 40/10 0071/0199/02



ECA

- PRC8 Enclavamiento puertas rellano centrales 8 paneles, modelo 40/10 y 50/11
8 panels centre opening landing doors lock, models 40/10 and 50/11 01/00-009/PR/R
- PRT4 Enclavamiento puertas de rellano telescópicas 4 paneles, modelos 40/10 y 50/11
4 panels side opening landing doors lock, models 40/10 and 50/11 01/00-009/PR/R
- Puertas rellano semiautomáticas modelos "Fermator" y "Global"
Hinged semi-automatic landing doors models "Fermator" and Global" S 7550



TUV SÜD

- PRC2 Enclavamiento puerta rellano central 2 hojas, modelo 40/10
2 panels centre opening landing door lock, model 40/10 D-97 ATV530/1
- PRC2 Enclavamiento puerta rellano central 2 hojas, modelo 50/11
2 panels centre opening landing door lock, model 50/11 D-97 ATV484/1
- PRC4 Enclavamiento puerta rellano central 4 hojas, modelo 40/10
4 panels centre opening landing door lock, model 40/10 D-97 ATV533/1
- PRC4 Enclavamiento puerta rellano central 4 hojas, modelo 50/11
4 panels centre opening landing door lock, model 50/11 D-97 ATV487/1
- PRC6 Enclavamiento puerta rellano central 6 hojas, modelo 40/10
6 panels centre opening landing door lock, model 40/10 D-97 ATV534/1
- PRC6 Enclavamiento puerta rellano central 6 hojas, modelo 50/11
6 panels centre opening landing door lock, model 50/11 D-97 ATV488/1
- PRT1 Enclavamiento puerta de rellano telescópica 1 panel, modelos 50/11
1 Panel side opening landing door lock, model 50/11 D-97 ATV483/1
- PRT2 Enclavamiento puerta de rellano telescópica 2 paneles, modelos 40/10
2 panel side opening landing door lock, model 40/10 D-97 ATV531/1
- PRT2 Enclavamiento puerta de rellano telescópica 2 paneles, modelos 50/11
2 panel side opening landing door lock, model 50/11 D-97 ATV485/1
- PRT3 Enclavamiento puerta de rellano telescópica 3 paneles, modelos 40/10
3 panel side opening landing door lock, model 40/10 D-97 ATV532/1
- PRT3 Enclavamiento puerta de rellano telescópica 3 paneles, modelos 50/11
3 panel side opening landing door lock, model 50/11 D-97 ATV486/1